



BULLETIN
OF THE
MADRAS GOVERNMENT MUSEUM
EDITED BY THE SUPERINTENDENT

**SOCIAL AND PHYSICAL ANTHROPOLOGY OF THE
NAYADIS OF MALABAR**

By
A. AIYAPPAN, M.A.,

NEW SERIES - General Section, Volume II, No.4

©
COMMISSIONER OF MUSEUMS

PUBLISHED BY
COMMISSIONER OF MUSEUMS
GOVERNMENT OF TAMILNADU
2002



BULLETIN
OF THE
MADRAS GOVERNMENT MUSEUM
EDITED BY THE SUPERINTENDENT

**SOCIAL AND PHYSICAL ANTHROPOLOGY OF THE
NAYADIS OF MALABAR**

By
A. AIYAPPAN, M.A.,

NEW SERIES - General Section, Volume II, No.4

©
COMMISSIONER OF MUSEUMS

PUBLISHED BY
COMMISSIONER OF MUSEUMS
GOVERNMENT OF TAMILNADU
2002

First Edition 1937
Reprint 2002

©
Commissioner of Museums
Government of Tamilnadu

Price : Rs.70/-

Printed at : **Smart fonts**
UNIT OF : ANUGRAHA EDUCATIONAL &
CONSULTANCY SERVICES P. LTD.
17/8, (Plot No. 391), 8th East Street,
Kamaraj Nagar, Chennai-600 041.
Ph: 492 6712 / 492 8700

Cover Page Print of 1937

BULLETIN

OF THE

MADRAS GOVERNMENT MUSEUM

EDITED BY THE SUPERINTENDENT

SOCIAL AND PHYSICAL ANTHROPOLOGY OF THE NAYADIS OF MALABAR

BY

A. AIYAPPAN, M.A.

NEW SERIES—*General Section, Volume II, No. 4*

MADRAS
PRINTED BY THE SUPERINTENDENT, GOVERNMENT PRESS

PRICE RS. 3-2-0]

1937

4

SOCIAL AND PHYSICAL ANTHROPOLOGY
OF THE NAYADIS OF MALABAR

BY

A. AIYAPPAN, M.A.,
Government Museum, Madras.

(Published December 1937)



Dr. R. KANNAN, Ph.D., I.A.S.,
Commissioner of Archaeology and Museums,
Government Museum,
Egmore, Chennai-600 008.

Phone { Off : 8261578
Res : 4341209
Fax : 8218735

FOREWORD

Dr. Edgar Thurston, then Superintendent of the Madras Government Museum first initiated ethnographic studies of South Indians. As a sequel to the monumental outcome of the ethnographic survey, several Anthropologists like Van Furer Haimendorf, Prof. A. Aiyappan and Thiru K. Rangachari have contributed a lot in this direction.

Prof. A. Aiyappan, the then Superintendent of the Madras Government Museum, undertook several ethnographic studies of both tribal and caste groups of South India, in general and in Tamilnadu, in particular. His monograph entitled "Social and Physical Anthropology of the Nayadis of Malabar" published quite sometime ago remains till date the role model for ethnographers who ventured to carry out a social anthropology study of any ethnic group.

This monograph is conveniently divided into three parts wherein Part I is devoted to the Social Anthropology of the Nayadis, Part II is devoted to the Physical Anthropology of the Nayadis while Appendices and the Index form Part III.

In this monograph, the Nayadis, a caste group of the erstwhile Malabar (of present Kerala State) was studied both extensively and intensively by Prof. A. Aiyappan. His scholarship is revealed vividly when he deals with the various spheres of ethnography of the Nayadis such as their "Social Organisation", "Religious Organisation" etc. under the Social Anthropology of the Nayadis. Prof. A. Aiyappan proves himself as an Action Anthropologist as he deals in this monograph with the measures for the development of the people under study. This is in contrast to the present approach of preserving ethnic diversity in the process of development. The 'Anthropometric data' collected on the Nayadis and the 'Glossary of Malayalam terms' used in the text are listed in Appendix I and II respectively. The Index part of this monograph will be of definite help to the readers to locate the desired aspects of their study easily.

It is hoped that this reprinting will fill the overt lacuna existed in the field of Ethnography of South India for a long span of time and will remain as a useful work of reference for the academicians, administrators, planners and researchers in the years to come.

CHENNAI-600 008
15-3-2002 AD

(Dr.R.Kannan, Ph.D., I.A.S.)

CONTENTS.

PART I—SOCIAL ANTHROPOLOGY.

	PAGE
INTRODUCTION—	
Scope of Study	1
Ethnographic Method	2
The Nayadi Country and its Cultural History	2
The Terms " Tribes," " Castes," and " Outcastes "	5
Census Figures	6
Nayadis and Ulladans	7
Previous References to Nayadis	8
LEGENDS OF ORIGIN	13
SOCIAL ENVIRONMENT—	
Meaning of the word " Nayadi "	15
Caste Setting in Villages	15
Cherumans and Nayadis	16
Iravans and Nayadis	17
Nayars and Nayadis	17
Non-Hindu Neighbours	17
Distance Pollution	18
Ambivalence of Upper Caste Attitude towards the Nayadis	20
Strange Notions about the Nayadis	20
NAYADI SETTLEMENTS AND MATERIAL CULTURE—	
A Bird's-eye View of Some Settlements	22
Huts	24
Domestic Goods	25
<i>Mannu</i>	26
Industries	26
Fire-making	27
Rat-traps	28
Agriculture and Livestock	29
SOCIAL ORGANIZATION—	
Territorial Division	29
Clans (<i>Illams</i>)	29
Joint Family	32
<i>Inangu, Sesham, and Bandhu</i>	32
Relationship Terms	34
Morphology of Relationship among Nayadis and other Lower Castes of Malabar—	
Father and Mother	34

	PAGE
SOCIAL ORGANIZATION—cont.	
Morphology of Relationship among Nayadis and other Lower Castes of Malabar—cont.	
Brother and Sister	36
Father's Brother, Mother's Sister, and their Children	36
Mother's Brother, Father's Sister, and their Children	36
Relationship Attitudes in the Nayadi Family—	
Parents and Children	38
Husband and Wife	38
Application of the Genealogical Method	39
Chieftaincy	40
BEGGING—	
Charity and the Begging Castes	41
Methods of Begging and Giving Charity	42
Death-Gift	43
Divination at the Time of the Death-Gift	44
Comparative Data on the Death-Gift	45
HUNTING—	
Nayadis as Hunters	45
Hunters' Gods	46
Manner of Trapping and Hunting	46
Distribution of the Kill	47
Hunters' Songs	48
<i>Nayattwidhi</i> or the Rules of the Chase	49
DIET—	
Sources of Food Material	51
Vegetable Food	51
Animal Food	52
Spices	53
Drinks	53
Intoxicants	53
Betel Chewing	54
Consumption of Food	54
DOMESTIC CEREMONIES AND CUSTOMS—	
Marriage	55
Puberty	59
Pregnancy and Child-Birth	60
Naming and Rice-Giving	61
Hair-Cutting and Ear-Boring	62
Death-Rites	62
RELIGION AND MAGIC—	
Gods and Ancestors	72
<i>Kalam</i>	72

CONTENTS

	PAGE
RELIGION AND MAGIC—<i>cont.</i>	
Nayadi Pantheon	78
Beliefs	80
Magic	81
Evil Eye and Evil Tongue	84
<i>Mattal</i>	84
PERSONAL DECORATION—	
Dress	85
Changes in Fashion	86
Hair-Dressing	87
Use of Oil	87
Tattooing	88
Nose Ornaments	88
Ear Ornaments	88
Neck and Breast Ornaments, etc.	89
RECLAMATION OF THE NAYADIS—	
Early Work of the Basel Mission	90
Occasional Conversion	90
Colony Scheme in Cochin State	91
Colony Schemes for Malabar Nayadis	92
The Olavakkot Colony	93
Iravan Reformers' Work at Kuzhalmannam	94
The Manjeri Colony	96
Nayadis as Labourers on a Government Farm	97
Establishment of Civic Rights	98
Employment in Public Service and in Factories, etc.	99
Conclusion	100
PART II—PHYSICAL ANTHROPOLOGY.	
INTRODUCTION	102
GENERAL CONCLUSIONS	103
MEASUREMENTS	104
INDICES	109
ANALYSIS OF NON-MEASURABLE CHARACTERS	113
SEXUAL DIFFERENCES IN BODILY CHARACTERS	118
PART III—APPENDICES AND INDEX.	
GENERAL TABLES OF STATISTICAL CONSTANTS, AND OF PERSONALIA, MEASUREMENTS,	
INDICES AND OBSERVATIONS	123
GLOSSARY OF VERNACULAR WORDS	136
INDEX	139

SOCIAL AND PHYSICAL ANTHROPOLOGY OF THE NAYADIS OF MALABAR

PART I. SOCIAL ANTHROPOLOGY

Introduction.

Scope of Study.—One of the unsolved problems in Indian Ethnology is caste. Many attempts have been made to explain the existence of the complex hierarchy of mutually exclusive but yet co-operative groups of people among the Hindus. These theoretical studies have been mostly discussions on the questions of race, clan, exogamy, tabus, etc., with reference to the various castes. No group of Indian people, except perhaps some of the jungle folk, exist or function by themselves, and yet the integrative aspects of the caste system have been largely lost sight of through the general over-emphasis placed on its centrifugal forces which are more obvious. A profitable field for research is to obtain clear and correct pictures of how each caste functions in its proper place in the caste milieu. Most of the studies on caste have scarcely referred to the working of caste on and among the lowest of the Hindu population, i.e., the so-called untouchables who are outside the four *varnas*¹ of theorists. What does caste mean to the lowest untouchable Hindu in Malabar? This is the central theme in the following pages on the sociology of a small group of people, the Nayadis, who are undoubtedly the lowest known caste in India. As the meanest of the mean among the Hindus, the Nayadis, who pollute by their approach even the Pariah, have attracted considerable attention during the last few years. Whether he is a European traveller or a social worker, no curious visitor to Malabar listens without being moved to the plaintive but stentorian cry of the Nayadi, begging for alms as he stands yards away from the road. The poverty and degradation of the Nayadis are such that about ninety years ago Christian missionaries started a home for their reclamation. So great is the misery of these people that state agencies also had to be brought into existence for looking after them. Social work for the uplift of the lower castes has now become a difficult administrative problem on which there is necessity for the fullest knowledge of all the various factors involved. It is hoped that the present paper will be found of some use in this connection as well as to the theoretical anthropologist interested in the behaviour and attitudes between the higher and lower castes, in the action of caste status on the economic life of a low caste, in the rather rare institution of hereditary and professional beggary, and in the manner of infiltration of Hindu concepts into a peripheral group only nominally within the Hindu fold.

¹ Grierson's system of transliteration has been followed here. See "Linguistic Survey of India," Vol. IV, pages 348-358.

Diacritical marks will be found in the glossary on pages 136-138 but it has not been possible to use them in the body of the paper.

Ethnographic Method.—Malinowski has stressed the importance of ethnographers giving a description of “the methods used in the collection of the ethnographic material.” He says, “I consider that only such ethnographic sources are of unquestionable scientific value in which we can clearly draw the line between, on the one hand, the results of direct observation and of native statements and interpretations, and on the other, the inferences of the author, based on his common sense and psychological insight.”¹ In ethnological work much depends on the degree of personal contact with the human material, the ethnographer’s capacity to understand the shades of difference in the linguistic expressions used and—above all—perfect empathy with the subjects. Being a native of the Malabar District I speak the same language as the Nayadis, and have long familiarity with the culture of the Malabar country of which the Nayadis’ culture is a minor part. But being a native of Malabar does not ordinarily mean that one knows everything about the Nayadis. No people are so shy and retiring as the Nayadis and the result of it is that even their neighbours know practically nothing of their rites and ways of life, much less of their beliefs. My knowledge of the Nayadis before I undertook the present study was very little. All the material presented in the following pages was collected during the course of five anthropological trips to the Nayadi areas from 1930 to 1935, during which period I came into personal contact with almost the whole Nayadi population. Extreme diversity of customs within this small caste of a few hundred souls became apparent in all its perplexity at the very outset of the investigation. But the frequent cross-checking of the evidence of several informants gives the data a great degree of reliability. My notes were taken in the language of the Nayadis—Malayalam—with a few words in English here and there of a purely theoretical nature. I found it advantageous to use such a mixture as this led to accuracy and brevity.

The Nayadi Country and its Cultural History.—The Nayadis are distributed in the three southern taluks of the Malabar District—Walluvanad, Ponnani, and Palghat—and in some of the most northerly villages of Cochin State adjacent to Ponnani (see the map in plate xii.). This area corresponds to the basin of the R. Ponnani which divides the Nayadi country into two halves. Not far from the mouth of the river is the famous village of Tirunavayi where the kings of ancient Malabar used to expose themselves once in twelve years to be murdered.² Running north-south almost parallel to the coast of the Arabian Sea, the jungle-clad Western Ghat mountains form the boundary between the Tamil district of Coimbatore and Malabar. Spurs sent westwards by the Ghats make the country extremely hilly except very near the coast line. Adjoining the north-east corner of the area of the Nayadis are the Nilgiris, the habitat of the well-known Todas. The lower slopes of the Ghats and their spurs are covered by deciduous forests with which the economic activities of the Nayadis are closely linked,

¹ Malinowski, “Argonauts of the Western Pacific”, 1932, pages 2-25.

² Frazer, “The Golden Bough” abridged edition, 1923, page 276, for the killing of the divine king at Tirunavayi.

for it is in them that they find their game for the chase, bark for rope manufacture, etc., and herbs for the native physicians' pharmacopœia.

The Nayadi area of Malabar is interesting to the pre-historic archæologist on account of its large number of dolmens and rock-cut tombs. As there is very little evidence of human occupation of Malabar during the palæolithic age, and the only neolith obtained by Bruce Foote from the district was from the Palghat taluk, it appears fairly reasonable to assume that Malabar derived its early population from the east during late neolithic times only. Dolmens are sometimes found right in the jungles, with the characteristic four-legged urns common to Malabar and to Coimbatore on the other side of the Ghats. These four legged urns are, according to Codrington, evolved from the many-legged cists and urns of Perumbair and Pallavaram.¹

Large numbers of the Nayadis live on the outskirts of the deciduous forests but as we go westwards their population grows sparser. What little we know of the histories of families on the coast indicates that migrations have been from east to west. So it is clear that the original home of the Nayadis must have been the outskirts of the jungle. The rise in price of agricultural produce since the introduction of India into the world market, after the coming of the English, led to every inch of land being brought under cultivation for commercial crops, and the very rapid growth of population made people encroach more and more on the forests, which were cleared and converted into arable land to grow rice. More and more men from the plains moved eastwards to the newly cleared areas displacing the original population. Thus came the Nayadis to live among the plains castes. No longer had they any monopoly of the small game of the jungle nor were they free to move about among their new neighbours. Deprived of their main source of food they had to depend on begging for their livelihood, and groups in search of fresh fields for begging began to wander further and further from their ancestral regions.

The Ponnani taluk (plate xii) has been exposed from very early times to foreign influences as Arab traders who then had a monopoly of the coastal trade of India used to visit Malabar ports and many of them settled down in the coastal villages. Native chieftains vied with one another in attracting the Arabs and in their efforts to do so encouraged the miscegenation of the fishermen of the coast with the Arabs. These Arabs brought Mohammedanism to Malabar; and in the course of a few centuries, the entire taluk came to have a large Mohammedan population. The town of Ponnani which is now the administrative headquarters of the Ponnani taluk is the religious centre not only of the Mohammedans of this taluk, but of the whole of Malabar. The Walluvanad taluk, on the other hand, is a mainly Hindu

¹ See, Foote, "The Foote Collection of Indian Prehistoric and Protohistoric Antiquities," page 64; Codrington, *Man*, 1930; Aiyappan, "Rock-cut cave tombs of Feroke," *Quarterly Journal of the Mythic Society*, Bangalore, 1933.

area with a very influential Brahmin population anxious to maintain the *status quo* of all castes. Malabar culture has undergone very little change in Walluvanad, for which reason it is full of interest to the Ethnologist. Palghat presents an entirely different picture. An opening in the Ghats sixteen miles in breadth known as the Palghat gap makes this taluk the meeting place of the culture of Malabar with that of the Tamil district of Coimbatore on the eastern side of the Ghats. But for the Palghat gap the ethnic isolation of Malabar would have been much more thorough.

The heavy monsoon rains, followed by the dry hot months from January to May, make the year divisible into two seasons, the rainy and the dry. The months June, July and a part of August are starvation months for the poor who have no store of rice, vegetables, etc. Incessant rain makes all out-door activities very difficult and the Nayadis find even begging difficult. But it is so arranged that this is also the season par excellence for feeding the poor by the rich. Great merit is attained by charity during these starvation months. After the harvest in September comes the festive season, and after the second harvest of paddy in January, the season begins for religious activities in the temples, which go on till the breaking of the monsoon in June.

The abundant rainfall and the fertile soil have between them been responsible for extreme overpopulation in Malabar. Added to this there is unequal distribution of wealth of a kind unknown in the neighbouring districts. The Namputiri Brahmins are not only socially the highest, but are so even from the point of view of wealth, they being the wealthiest landlords both in the Ponnani and the Walluvanad taluks. In few other parts of India do the Brahmins have the same economic advantages as they have in Malabar. Hence the proverb in Malayalam, "Malabar is a heaven for the Brahmins, but a hell for others." Isolation from continental influences from across the Ghats has had the effect of making the Namputiri Brahmins an extremely narrow-minded group, and the caste system of Malabar most hide-bound. The custodians of orthodoxy happened to be here the oppressors, both socially and economically, of all the castes below them who were also their tenants at the same time. In the midst of the plenty enjoyed by the higher castes there exist an army of labourers, permanently famine-stricken, living under conditions of slavery, receiving wages in kind only, and actually termed 'slaves' by their employers. Men and women of the labouring classes in Malabar look more famished when compared with similar people of the east coast districts whereas the higher castes compare quite favourably with their peers in any part of the Madras Presidency. The weight of caste tyranny on the lower castes is the severest also in Malabar; nowhere is the curse of untouchability so manifestly cruel as here.

Into this Brahminical paradise, which was the hell of other castes, came in the early years of the Christian era the St. Thomas or Syrian Christians and later on the Muslim Arabs.

These non-indigenous religions with a social organisation that attempted to do without distinctions of caste came as a great relief to some at least of the most oppressed of the Hindu castes of Malabar. The presence of Islam and Christianity had the natural effect of weakening the powers of caste for evil. Until the coming of the British the Brahmins were quite powerful because the motto of the native rulers was primarily to 'protect the Brahmins and the cows.' Since the East India Company annexed Malabar from Tippu Sultan of Mysore, all Hindu political power disappeared, but Hindu Society was little affected and its structure remained the same as before. During the early years of the British rule social legislation to emancipate the lower castes from tyranny of the high caste men was actively pursued, but against strongly ingrained prejudices which all the subject people shared in a hierarchical form, a foreign government, however powerful and well-intentioned, could do very little. But now, fortunately, the Hindu public is becoming slowly alive to its own weakness and is itself urging for reforms which two decades ago it would have opposed.

The Terms " Tribes," " Castes," and " Outcastes."—The loose use of the terms tribe, caste, and outcaste in early survey works in ethnology without defining their meaning has left us a legacy of confusion. Sylvain Levy, for example, in his introduction to " Mysore Tribes and Castes " (p. lxix) refers to the difficulties that he had in differentiating between tribes and castes. He says, " If I have understood aright, and as far as Indian data can be embodied in formulae, the tribe is a prospective caste which has not yet attempted to adapt itself to the sacred mould of Hinduism ; the caste is a group which, consciously or not, voluntarily or not, has accepted at least in their broader definitions, the principle of the traditional order that the Brahmans have instituted " (p. lxx.). The meaning of the word tribe, according to the Shorter Oxford Dictionary is " any primitive or barbarous people under a chief." The official use of the term tribe in India has been more or less in agreement with the meaning given above. The definition of tribe given in " Notes and Queries in Anthropology " 5th edition (p. 54), lays emphasis on " a common language and a sense of ' idarity." In the Encyclopædia Britannica (11th edition), the families or small communities that constitute a tribe are said to trace their descent from a common ancestor. If, however, descent is taken into account, almost every caste that makes the Hindu community of the Malayalam-speaking area will have to be given the status of a tribe although they speak a common language, Malayalam. Conditions in India being peculiar and caste organisation being specially Indian, definitions that hold good for other areas, when applied to groups of Indian peoples at various levels of complexity in culture are apt to be found to be unsatisfactory. The test of Hinduisation has therefore been suggested to decide whether a group of people are to be styled a tribe or a caste ; if Hinduised it is a caste, if not, a tribe. But Hinduisation by itself is not a sufficiently well defined cultural category to help us to an easy decision of the position of a group of people. The Todas of the Nilgiris are, for example, a very good example of a tribe. It is well known that they are getting Hinduised, i.e., going on

pilgrimage to Hindu temples, and daubing their foreheads with the sacred ashes, but yet they are not regarded as a caste on that account. Something more than mere Hinduisation is necessary to make a people a caste. It is the degree of integration with the general body of the local Hindus that settles whether a people are within the Hindu community or without it. The first step in the integrative process is the settlement of the position of the group in the hierarchy of castes ; then follow economic and cultural associations that determine later on the privileges and duties of the caste. Consideration of factors of integration leads us to class the Nayadis as a caste rather than as a tribe.

To avoid the confusion between outcastes and outcasts, Hutton has suggested the use of the expression " exterior castes " for the former. The Malayalam classification is *mel jati* (upper castes) for the castes from Brahmins to Nayars (Sudras) and *kir jati* (lower castes) for castes from Iravans to Nayadis. These terms are therefore used in this sense throughout this paper.

In Brahminical works on caste in Malabar the superiority or inferiority of the lower castes among themselves is usually decided by considerations of nearness and utility to the upper castes. For example, though the Malayans (a hill tribe) and the Nayadis have not yet settled among themselves which is the superior of the two, the upper castes regard the Malayans as inferior to the Nayadis, because the latter are better known to them. The Kadars of the Cochin jungle on the other hand, in spite of their distance from the upper castes, are regarded as superior to the Malayans, because caste Hindu contact with the Kadars is very recent and the assertion of the Kadars regarding their superiority is accepted without any questioning. In the Census Report for Madras, 1901, the Nayadis are included among " castes which pollute even without touching, but do not eat beef." Beef-eating castes are usually the lowest among the Hindus, but in Malabar the beef-eating Parayan is the superior of the Nayadis. The Cochin Census, 1912, describes the Nayadis " as an animistic tribe " and as the " laziest and the most uncleanly people in the State." The term ' animistic ' is meaningless in its application to most of the tribes, since it does not distinguish them sufficiently from the main sections of the Hindus and animism forms part of the faith of most of them. Concerning the second remark quoted, *see* below p. 101.

Census Figures.—The Nayadis according to the Census returns of 1931 number 709 and are distributed in the Cochin and Travancore States and in British Malabar. Dr. Kunjan Pillai, Superintendent of Census Operations in the Travancore State, informs me that 144 Nayadis returned in his report might have wandered into the State from the adjoining Cochin territory. As there are only Ulladans and no Nayadis proper in that area of Cochin, it seems probable that an error has crept in due to the enumerators confusing Ulladan for Nayadi. After subtracting this 144 from the official total, the entire Nayadi population in the Malabar

and Cochin areas is 565. The table of Census figures show that the Nayadi population has been steadily decreasing.

Census returns for Nayadis from 1891-1931.

	1891.	1901.	1911.	1921.	1931.
Malabar—					
Total	522	520	535	417	413
Male	280	257	273	200	209
Female	242	263	262	217	204
Cochin—					
Total	215	220	119	152
Male	116	76
Female	99	76
Travancore—					
Total	18	...	182	144
Male	109	...
Female	73	...

Nayadis and Ulladans.—In the Malayalam work known as *Keralolpatti* (= Origin of Malabar) Nayadis are classified as one of the sixteen hill-tribes of the district. Another book in the same language, *Jatinirayam* (= Determination of Caste) lists the Nayadis with the Parayans, Pulayans and Ulladans under the head "*Nattu nichanmar*" (= low castes of the country), as distinguished from the lower castes of the jungles. The author of *Keralolpatti* gives the Nayadis a rank just above the Ulladans, for what reasons we do not know. While this ancient vernacular work does not confuse the Nayadis with the Ulladans, recent writers have made an unnecessary terminological tangle by using one caste name for the other. In an official communication the Protector of Depressed Classes in the Cochin State uses Ulladans and Nayadis as synonyms. Iyer regards Nayadis as one of the four septs of the Ulladans, and adds that "there is no interdining or intermarrying between these different septs and popularly the Ulladans and Nayadis are regarded as separate tribes."¹ On the other hand, both the Nayadis and the Ulladans regard themselves quite distinct from each other.

We do not know by what name either the Ulladans or the Nayadis called themselves before they received these names from the men of the plains. Since they both have essentially the same ways of life, there is some ground for people uniting them under a common caste name. Sociologically, however, there is no justification for it. The Nayadis proper, who are distributed in the southern taluks of Malabar and the northern taluks of the Cochin State, are an isolated group regarding themselves as a kinship and marriage group. Between the Nayadis and the Ulladans there is a wide tract of country and there is complete absence of even a traditional link to unite them. The two Ulladan groups in the southern regions

¹ Iyer "Cochin Tribes and Castes," Vol. I, page 59.

of the State, the Hill Ulladans and the Plains Ulladans are, in spite of their cleavage into non-intermarrying divisions, linked up by traditions, a common name and many common practices and usages.

Though distinct from the Nayadis, the Ulladans are nevertheless their counterparts in the southern regions of Cochin State and the northern parts of Travancore. A missionary writer of Travancore wrote about them : "The Ulladans are a true jungle (?) tribe of wild and timid savages, whose subsistence and life are miserable and pitiful. They were without settled villages and civilised clothing, wandering within certain boundaries prescribed to each division, living a few months in one spot till the crop of ragi is reaped, then decamping to another place more likely to be productive of wild yams, arrow-root, and other esculents, which they find in the jungles, and for grubbing up which they are generally armed with a long pointed staff. They also further enjoy the fruits of the chase and are adepts in the use of the bow and arrow. . . . A few Ulladars of the low country say that they or their fathers were stolen in childhood and brought down as slaves."¹ This must have been the Nayadi way of life before they came down and became beggars. The Ulladans are now divided into two groups, those of the plains and those of the hilly tracts, both behaving towards each other as though they were separate castes, without intermarriage and inter-dining. The Ulladans of the plains are those that came down to the banks of the backwaters. The Pulayas who are their neighbours in the villages near Ernakulam address the Ulladans as *Maratton* (he of the trees), a term which will last and indicate the link of the Plains Ulladans with those of the jungles. Long contact with the Christians and the Hindus have changed the Plains Ulladans beyond recognition. The women have dropped their bead ornaments and deck themselves as the fisherwomen of the Ernakulam coast do and prefer a mere string to the profusion of beads which their ancestresses loved. To them a string of beads is an indication of lowness. The men beg, but they have a new profession, namely canoe-making and minor items of carpentry work. The Ulladans have entirely new marriage customs, new names for both men and women, but along with these they have their old hill gods still worshipped, and the women are during their monthly periods secluded in menstrual huts as their sisters of the hills. The Ulladans of the hills in the interior who have changed very little are looked down upon by the men of the plains.

Previous References to Nayadis.—The earliest literary reference to the Nayadis in the Malayalam language is in the *Keralolpatti* wherein the caste is mentioned in the list of the *chandalas*, following the Brahminical system of classification of castes. The people of Malabar believe that the author of the system was the great philosopher Sankaracharya, a Malabar Brahmin or *Namputiri*, himself once excommunicated, and that he was particularly rigid and severe on his own countrymen because of the hardships which he was put

¹ Mateer, "Native life in Travancore", London, 1883, page 80.

to on the occasion of his mother's death when none of his castemen would help him. Though the *Keralolpatti* is of doubtful authority as a history of the "origin of Malabar", which it purports to be, it records one important fact which has a bearing on the problem of unapproachability in Malabar, namely, that the castes that now pollute from a distance, were formerly considered to be untouchables, polluting only on physical contact. "On account of their misdemeanours were these castes made unapproachable."

In '*Nayattuvidhi*'—an unpublished work of considerable antiquity on the methods of hunting — are found references to the part to be played by the Nayadi in the chase (See pp. 49-51).

In a Portuguese MS. (Sloane MS—2743-A—British Museum) of about 1676 A.D. describing the castes of Malabar there is the following short paragraph about the Nayadis :

" 16. Naddi : they are a caste of hunters, and have no other occupation, and they go about with their bows and arrows and are obliged to accompany the Naire, Gentio, and Christian hunters." ¹

The earliest notice of the caste in the English language is by Welsh in his *Military Reminiscences* (1730) :

" Whilst on the subject of caste distinctions, I must mention a still more extraordinary race, called the Nayaree or Niaree, the lowest and the most abject of human beings who inhabit the jungles and the wild uncultivated parts of this coast, and are far inferior to the native Bengalees, below Calcutta, or the Bheels near Surat, in appearance and stature. They are nearly jet black with bushy hair, and features approaching to the Caffres ; have a language of their own, never build houses or wear any clothing, and dare not on any pretence approach any other inhabitant of the coast. They live on trees, in bushes or in holes in the ground ; are little above brutes in intellect or at all events in its display. They crawl to the roadside, or to a certain distance from a habitation, deposit something, such as a bundle of twigs, some wild berries or honey-comb, set up a loud and hideous shriek or scream and then retire to a sufficient distance to watch the result ; when the nearest person either converses with them at a distance on the exchange or at once deposits what may serve their purpose, and gets out of the way to enable them to approach and carry off their supplies, without personal contact. I had remarked them several times in my travels, before I had an opportunity of ascertaining the above particulars from a native, who could converse in Hindustanee, and I afterwards had the pleasure, in company with Mr. Baber, of not only assisting them in the common way, but of raising them in their own estimation, by an unreserved intercourse, and employing them for some days on a shooting excursion ; when we also employed Nairs and Teers, as interpreters. Touching them ourselves, we easily persuaded our attendants to do the same ; and the same time purchased and exchanged trifles, and gave them daily payment for their labours in the

¹ Kerala Society Papers, Vol. II, Series 9, 1932, page 196.

jungle. The high estimation in which Mr. Baber stood with the Natives, operating against their long-established prejudices, two young Nairs, of most respectable parentage, were the foremost in showing their kindness to these miserable outcastes, and they consequently became most useful in scouring the thickest jungles, where no other naked mortal would have dared to venture and drove the game towards us in all directions. They also made small baskets, ropes, etc., which they brought for sale every morning, and which though rude, and, to us, perfectly useless, we took to encourage them in the habits of industry. The two Nairs I have mentioned named Keeloo and Konnon, were both very promising lads, well-versed in the Bible, and appeared to wish to profess Christianity”¹

By Nayaree or Niaree Welsh undoubtedly means the Nayadi. The Malayalam spoken by the Nayadis used to be generally unintelligible to those not accustomed to it, and perhaps the difficulty that his guides had in understanding them may have led Col. Welsh to think that the Nayadi had a language of his own.

Visscher (1743) wrote as follows about the Nayadis and their close allies the Ulladans :—
“ Besides there are three jungle castes, first the Ollares, who collect honey and wax in the jungles, where these articles are found in abundance, and are brought down to the coast by merchants and thence exported to other countries. The Ollares wear no clothing, and regard the tiger as their uncle. When one of these animals dies, either naturally or by violence, they shave their heads in token of mourning, and eat no cooked food for three days ; they eat no flesh, but that of animals which have been killed by tigers, so that the existence of these wild beasts is of great consequence to them.

“ The Vedden and the Niaddy are also bushmen who hunt wild beasts and subsist upon their flesh as well as upon herbs and roots ; so that there are many among these three castes who have never tasted rice”²

Buchanan (1803) has left us some very valuable remarks about the condition of the Nayadis :

“ The Niadis are an outcaste tribe common in Malabar but not numerous. They are reckoned so very impure that even a slave will not touch them. They speak a very bad dialect and have acquired a prodigious strength of voice by being constantly necessitated to bawl aloud to those with whom they wish to speak. They absolutely refuse to perform any kind of labour ; and almost the only means that they employ to procure a subsistence is by watching the crops to drive away wild hogs and birds. Hunters also employ them to rouse game ; and the *Achumars* who hunt by profession give the Niadis one-fourth part of what they kill. They gather a few wild roots but can neither catch fish nor any kind of game. They sometimes procure a tortoise and are able by means of hooks to kill a crocodile.

¹ Col. James Welsh, “ Military Reminiscences,” London, 1730, Vol. II, page 111.

² Visscher, “ Letters from Malabar,” page 129.

Both of these amphibious animals they reckon delicious food. All these resources are, however, very inadequate to their support and they subsist chiefly by begging. They have scarcely any clothing and everything about them discloses want and misery. They have some wretched huts built under trees in remote places ; but they generally wander about in companies of ten or twelve persons keeping a little distance from the roads ; and when they see any passenger, they set up a howl like so many hungry dogs. Those who are moved by compassion lay down what they are inclined to bestow and go away. The Niadis then put what has been put for them in the baskets which they always carry about. The Niadis worship a female deity called *Maladeiva* and sacrifice fowls to her in March. When a person dies all those in the neighbourhood assemble and bury the body. They have no marriage ceremony ; but one man and one woman always cohabit together ; and among them unfaithfulness, they say, is utterly unknown.

“ A wretched tribe of this kind, buffeted and abused by every one and subsisting on the labour of the industrious is a disgrace to any country : and both compassion and justice seem to require that they should be compelled to gain a livelihood by honest industry and be elevated somewhat more to the rank of men. Perhaps Moravian missionaries might be employed with great success and at little expense in civilising and rendering industrious the rude and ignorant tribes that frequent the woods and hills of the peninsula of India. In the execution of such a plan it would be necessary to transport the Niadis to some country east from Malabar, in order to remove them from the contempt in which they will always be held by the higher ranks of that country.”¹

Buchanan is wrong in thinking that the Nayadis spoke a dialect of Malayalam language and that they refuse to perform any kind of labour. *Maladeiva* (= *Maladeivam*) is a male and not a female deity. But the most egregious of all Buchanan's errors is in his statement that there is no marriage among the Nayadis. Buchanan was, however, the first European observer to point out that it was a public obligation as well as a social duty of the upper castes to elevate the Nayadis from the mire of wretchedness. His remarks were recorded shortly after the annexation of Malabar by the East India Company and it was more than a century before his suggestion was adopted by the Government.

Lieutenant Connor (1833) wrote thus of the Nayadis : “. . . the Naidees . . . are at the very last step of vileness. This wretched race is only found in the northern parts of Cochin, they are banished the villages, and live on the low hills near the cultivated lands—a bush or rock being their only shelter. The Naidees present a state of society not seen in any other parts of India ; wild amidst civilized inhabitants, starving amidst cultivation, nearly naked, they wander about in search of a few roots, but depend more on charity . . .”².

¹ Buchanan, “ Mysore, Coorg and Malabar,” Vol. II, page 413, 1803.

² *Madras Journ. Lit. Sci.*, I, 1833, page 7.

Pharoah's Gazetteer (1855) has the following about the Nayadies :—

" *Nagadies*.—These poor creatures present perhaps the lowest type of humanity. They have neither occupation or property ; they do not till the soil ; they have no weapons with which to hunt and destroy wild animals. They live a life of the utmost want and misery subsisting upon offal and wild roots, and what else the charity of others may bestow. They do not, like the hillmen, live away from the sight of others, but are to be seen in the open country howling and yelling from a distance after passers-by, running after them till something is thrown down in charity, which they will come and pick up after the traveller has passed on. They are not allowed to approach within 96 feet of Hindus, but so degraded are they that they generally observe a much greater distance from all other human beings. They enter no town or bazar, but deposit their money on some stone at a distance, and trust to the honesty of the bazar man to give what goods, and what quantity of them he thinks fit in return.

" They marry and have been praised for their fidelity, truthfulness and honesty, to which they have in reality but little claim. Polygamy and adultery are sins common amongst them. They also steal, and are in fact in every respect just as bad as any other caste.

" They are beggars by birth and trade, and will on no account accustom themselves to a life of regularity and industry. Many of them have during the last two years become Moplahs.

" Fortunately for them the Hindus have a superstitious belief in the efficacy of charity shown to them, and in the power of the charms which they practise. They are accordingly fed by them on various occasions, as birthdays and other times of rejoicings. Especially this practice is observed when any member of the family is sick, and supposed to be dying.

" The Nagadies are supposed to be the descendants of outcast Brahmins, excommunicated for some great offence. The names of the present race are the same as those borne by Brahmins ; but their appearance does not support this traditionary origin. In complexion they are invariably of the deepest black, their hair is seldom straight, but generally very thick and curly, their features are brutish, and their forms diminutive. In their habits they nearly approach the conditions of the wild animals. A woman when her travail is approaching, retires entirely by herself to the shade of some tree, and is there delivered, returning after a few hours to her usual place of abode."¹

To Francis Day (1863) of Cochin we owe the account of the humane work that Mr. Conolly tried to do to elevate the Nayadis. Mr. Conolly was one of the best of English administrators in Malabar and his brutal murder by a Mohammedan (Moplah) fanatic is still remembered with horror. " Near Calicut Mr. Conolly established a colony for Nayadis and gave them ground to cultivate. After sometime, Government handed the experiment

¹ " A Gazetteer of South India," Madras, 1855, pages 521-2.

over to the German Mission who sent them a resident schoolmaster, and thus succeeded in converting and baptising three of them. The Moplahs then determined on proselytising this set of people and suddenly all but the three, who had been baptised, left the mission village, and were received into the Moplah community, where they speedily became converts to Islam." ¹

Jagor (1894)² published a short article on the Nayadis, and more important than that the Nayadi godling figures in the Berlin Museum of Ethnology which he collected seem to be the only ones of their kind now existing (plate ix, figs. 2, 3).

Appadorai and Thurston (1901),³ Panikkar (1903),⁴ and Aiyer (1905)⁵ have given brief survey accounts of the Nayadis.

Legends of Origin.

There are many stories current both among the Nayadis and their neighbours the purport of all of them being nearly the same, namely, to give the Nayadis a very exalted origin from the highest caste in the land, the Namputiris. In bygone days when violation of any caste-rule meant excommunication for the Namputiri, it is perhaps possible that some outcast individuals may have resorted to the jungle and become members of the hunters' camps. The practice nowadays of excommunicated Hindus adopting Islam or Christianity could not be there prior to the first century A.D. Outcasts, then, we are told, usually became slaves. Logan makes mention of an arrangement in North Malabar by which outcast Namputiri men and women were sheltered and maintained by a Tiyar chief who is known to tradition as the *Mannanar*. But even this arrangement is almost unheard of in the southern part of Malabar which has a bigger Namputiri population. Our ignorance of what usually happened to excommunicated members of high-caste Hindus coupled with the fact that most of the Nayadi names, such as Nanneli, Sita, for women and Nilakanthan, Sankaran, for men are upper caste names, quite incongruous with the low status of the bearers of the names, gives some plausibility to the legends of origin. Upper caste Hindus do not consider the Nayadi as an unclean caste in the same sense as the Parayan, for instance, is regarded as unclean, and remarks have been very often heard from the lips of very orthodox Brahmins that they could still detect something of the old nobility in the face of Nayadi men as well as women.

A legend that has currency in the Palghat taluk runs thus :—A Namputiri once met a beautiful Malayan (Malabar hill tribe) and became enamoured of her. In the course of a conversation he mentioned this to a friend of his. The crime of falling in love with a daughter of the wilds was considered sufficiently serious by the caste council to award him the highest

¹ Day, "Land of the Perumals," Madras, 1863, pages 333-4.

² *Zeitschrift für Ethnologie*, 1894.

³ *Madras Government Museum Bulletin* (Old Series), IV, 1901.

⁴ "Malabar and its Folk," 1903.

"Tribes and Castes of Cochin," I, 1905.

punishment—excommunication. The present-day Nayadis are supposed to be the offspring of this Namputiri and his Malayan love.

Another story of origin from the same locality is very simple :—A group of Namputiris went to a tank to bathe. While the others were bathing one of them stood away from the water's edge and would not perform his ablutions. He was forthwith declared an outcaste, and he became the founder of the Nayadi tribe.

The following legend is current among all Nayadis :—

When a party of Namputiris were travelling to a certain place, one of them who felt hungry picked up and ate a mango that had been partially eaten and dropped by a monkey. Eating an unclean thing, when he too was in an unclean state, was a crime against caste, for which the poor man was excommunicated. His descendants are the present-day Nayadis. At least one Nayadi who narrated this story to me believed it to be fully true and felt genuinely sorry for the foolishness of his Brahmin ancestor. Raman, the chief Nayadi of Kunnamkulam, was once told by an old and kindly Namputiri (so he reports) that he too had the Brahmin blood in him just as any Namputiri.

According to some members of the upper castes in Malabar, the Nayadis were Brahmins, but were cursed for their misconduct and were asked to expiate their sins by doing penance standing on one leg. The Nayadis have a habit of standing on one leg supporting the weight of their body on a staff which they always carry with them. This is one of the characteristic Hindu explanations for the lowliness of certain castes—expiation of their past sins. This story is undoubtedly a rationalization based on a peculiar mode of standing at ease.

There is yet another legend to account for the skill of the Nayadis as archers, and to give them a Brahmin ancestry. Some Namputiris who were well-versed in Dhanurveda—the science of archery—wantonly shot dead many animals and when it came to the knowledge of the chief priests the delinquents were excommunicated. They went to the jungles and from them arose the Nayadis.

The Ulladans near Ernakulam in Cochin State narrated a story regarding their connection with Namputiri Brahmins. One of the ancestresses of the Ulladans of Kalur, a village near Ernakulam, was a Namputiri woman who lost her caste on account of adultery. The usual practice in such a case is for the woman to become a Christian or a Mohammedan, but in this particular instance her relatives gave her away to the Ulladans, in order that, though an outcaste, she might remain a Hindu. The descendants of the Ulladans concerned told me that both they and the descendants of the Namputiri house referred to still remember the incident and that whenever something untoward happens in the particular household they make it a point to invite the Ulladans and to please them with presents. I was unable to enquire about this from the Namputiris themselves. If the periodical gifts to the Ulladans are withheld, then, the story goes, the image of the god worshipped by the Namputiris in their domestic shrine will fall down. The Ulladans told me that the Namputiri woman is among the “mothers” who are represented by pebbles in their *mannu*, the place of worship.

The *Halle Makkalu* ("old sons"), low castes similarly linked with many of the non-Brahmin castes of the Canarese country, have the right of demanding alms from the higher castes to which they are affiliated.¹ On every important occasion, the "old sons" of the caste have to be given alms in cash and kind. The *Halle Makkalu* consist in each case of a few families living side by side with the "parent" caste. The Nayadis have no such right to beg of any particular caste, though legends link them with the Namputiris. Their physical appearance is strong evidence against the legendary theory of the origin of the Nayadis from Namputiris.

Social Environment.

Meaning of the Word "Nayadi."—Dr. Gundert, the first lexicographer of the Malayalam language, and later Malayalam translator to the Madras Government, gives the word *Nayadi* two meanings: (1) a hunter, and (2) 'the lowest caste of jungle dwellers ordered to retire seventy-four steps from the high castes.' *Nayadi* with both the 'a's long is the correct name of the caste. *Nayadi* with the second 'a' short which Dr. Gundert gives as an alternative name is used in colloquial Malayalam in some parts of Malabar, but here the second 'a' is shortened because of the natural difficulty in pronouncing the two 'a's long. Some scholars try to identify the Sanskrit *Svapacha* (dog-eaters) with the Nayadis, because the word for dog (*naya*) is there as part of the name. According to no tradition are the Nayadis dog-eaters. Of the names by which the hill-tribes of Malabar are to the men of the plains, such names as Malayan and Kadar refer to their forest habitat, while Paniyan (farm-labourer) and Vedan (hunter) are descriptive of their profession. In no tribal name is any reference made to special articles in the dietary of the people. When men of the plains first came in contact with the Nayadis they were only hunters and not beggars. The word "*Nayadi*" which, like Vedan, means "hunter" can have no other meaning than this as the name of the tribe.

Caste Setting in Villages.—The Nayadis as a Hindu caste live their lives amidst their co-religionists of higher castes. Each caste, however insignificant, contributes to the cultural whole of the country and its life. It is important that the Nayadis should be studied in their social setting in order to understand their contribution to the culture of Malabar and their relationship with other castes there, and to analyse the forces that tend to keep them together or act in the opposite direction.

A Malabar village differs from a village of the Tamil or Telugu country in many respects; in the former each household lives in the privacy of a garden, while in the latter, the houses are aligned in streets and the lower castes are segregated in what are called *cheris*, a group of miserable huts huddled together. A Tamil village is a town in miniature, while a Malabar village is somewhat like a garden city with the distance between one

¹ Mackenzie, J. S. F., "*Hulle Makkalu*," *Indian Antiquary*, I, page 380 and II, page 30.

household and the next rather exaggerated. The various castes are not segregated, but live interspersed among one another. The agricultural serfs, or Cherumans, who are the hereditary labourers of a particular landlord will usually live not far from their master's residence for the latter's convenience. It is the economic need of the landlord that induces him to settle his low caste workers near him, though the latter are socially far inferior to him.

Cherumans and Nayadis.—In the caste hierarchy of Malabar, the Cherumans are the immediate superiors of the Nayadis and therefore, compared to others, there is more social intercourse between the Nayadis and the Cherumans. Until the time when slavery was abolished in Malabar, the Cherumans were bought, sold or mortgaged as slaves by their masters. When a piece of land was sold the slaves attached to that part of the estate were usually sold with it. Even nowadays in the interior villages of Malabar the Cherumans are treated as virtual slaves, ill-paid, beaten, and forced to work for a mere pittance. Such a miserable caste as the Cherumans regard themselves as the superiors of the Nayadis. The Cherumans are polluted by the approach of the Nayadis just as the higher castes are by both of them. As the Cherumans are the class on which farmers chiefly depend for rice cultivation, the landlords cannot employ Nayadis as agricultural labourers without the consent of the Cherumans, who, however, resent their employment and refuse to work side by side with them as the nearness of the latter (Nayadis) pollutes them and necessitates their bathing and purifying themselves before eating any food during the intervals between their working hours. The Cherumans do not eat anything cooked by Nayadis or any cooked food touched by them, nor will they drink water touched by them. In toddy shops, a meeting place of all people, there are separate earthenware cups for the Cherumans, but none for the Nayadis, and the shopkeeper has to pour the drink into drinking vessels which they get for themselves. The Nayadis eat food cooked by the Cherumans and drink water touched by them. Another caste on a par with the Cherumans are the Parayans, but the Nayadis will not eat food cooked by the Parayans, because the latter are carrion eaters, while the Nayadis are not. The Cherumans address Nayadis by their name, but the latter should add the honorific title '*Molayan*' to the Cherumans' personal names when addressing them. If a Cheruman's name is Raman he is addressed as Raman Molayan. Lack of reciprocity in expressions for personal address is one of the features of the hierarchical usages of caste. The distance from which the Cherumans are polluted by Nayadis being short and since both are kept at a great distance by the upper castes they are forced to be neighbourly. From the Cherumans the Nayadis learn their dances and songs; they also watch the Cherumans' ceremonies, artistic and economic activities, and absorb as much of them as they can. Some Nayadis shave their heads clean as do the Cherumans, but the Cherumans resent this as being an attempt to assume equality.

Iravans and Nayadis.—Most of the other Hindu castes have very little to do with the Nayadis except giving them alms, and sundry offerings, e.g., the death-offerings (pages 41 ff. below). Of the other castes, that known in different places as Iravan, Tandan or Tiyān comes next to the Cherumans. The Nayadis of the Pāghat taluk address the Iravan as 'Muttappan' (grandfather). The Iravans in addition to being agriculturists are producers of toddy from the palmyra and the coconut palms. The Nayadis beg for doles of toddy from the shops and also purchase it when they have the money. For all ceremonies the Nayadis require toddy. They have to remain several yards away from the shop, cry out to the shopkeeper and complete all transactions from a distance.

Nayars and Nayadis.—Superior to the Iravans are the Nayars. Nayars being economically better off than Iravans, the Nayadis get more by way of alms and death-offerings from them than from the Iravans. Nayars purchase from Nayadis articles made of rope, such as ropes for drawing water from wells with palm-leaf buckets, collar ropes for cattle, slings, rope *Uris* (plate x, fig. 2) for keeping vessels suspended, barks used as soap for removing oil smeared on the body, and also medicinal herbs from the jungles. The upper castes are polluted by the Nayadis from a distance of at least a hundred feet, but certain individuals who want to maintain themselves in a very pure state insist on the Nayadis keeping themselves at a distance of even a hundred yards from them. The Nayadis address a Nayar as 'Tampurān' (lord) whether the Nayar be a beggar or a chief. A member of an inferior caste in Malabar when he meets one of a superior caste has to behave towards the latter in a particular manner, to show respect. When a Nayadi meets a Nayar at a distance he gets away from the path of the latter very expeditiously in order not to be within polluting distance, and shows respect by (1) holding his palm-leaf umbrella slant, instead of having it vertically over his head (plate v, fig. 1); (2) removing any piece of cloth that is thrown over his body or on his head; (3) covering the mouth with the right palm; and (4) shrinking, i.e., bending the body and drawing the shoulders inwards. In conversation the first person singular has to be avoided and be replaced by 'atiyan' (slave). There is a large vocabulary of 'respectful words' which have to be used in conversation with the superior castes, i.e., by Nayars when they speak to the Namputiri Brahmin, by Iravans when they talk to Nayars and Namputiris, and by Nayadis when they speak to any person who is not a Nayadi. The object of these sets of terms is to exalt the man of the superior caste and demean the lower. Thus a free rendering of a simple sentence spoken by one of the Nayadis to me referring to my visit to their place the previous year and giving them enough money to have sumptuous meals is as follows:—"The lord came in procession last year to the slaves' mean hovel and the slave children got enough copper coins to buy gravelly rice to fill their stomach."

Non-Hindu Neighbours.—In the densely populated coastal tracts of the Malabar district Nayadis mix freely with Mohammedans (Moplahs) and in Cochin State with Christians,

as neither of them observe touch tabus,* etc., as do Hindus. Many Nayadis work as the domestic servants of Mohammedans. Mohammedan and Christian pedlars bring to the Nayadis the few articles of luxury that they possess, such as combs, mirrors, brass or iron ornaments. Vannan (washerman) or Iravan physicians treat Nayadi patients rarely, but their midwives never attend Nayadi women. In the few cases known to me it was Moplah women that rendered assistance as midwives. Mohammedans and Christians employ Nayadis occasionally for odd jobs on their farms. Nayadis who work for Mohammedan masters have the peculiar Moplah mannerisms in their speech. From service under a Mohammedan to the adoption of the Muslim faith only is a short step.

Distance Pollution.—There seems to be no definiteness anywhere as to the distance from which the Nayadis convey pollution to castes above theirs. In published works and according to traditions seventy-four to hundred feet are prescribed. But in practice the Nayadis keep themselves at a greater distance than the prescribed minima. At Vilayur in Walluvanad taluk there is a spot known as *tintal para* (pollution rock), three furlongs from the nearest Hindu house, beyond which the Nayadis cannot approach the village. Pollution distance bears some relation to the utility and services rendered by the polluting castes. The carpenters who are more useful to the Nayars and the Namputiri Brahmins than the Iravans have a lesser polluting distance than the last though they (Iravans) are superior to the carpenters in caste gradation. Similarly when a Nayadi is invited to receive the death-offering (see pages 41 ff.) he is allowed to go nearer than usual.

Very strange ideas prevail about the intensity of distance pollution. It is said that, in order to purify oneself after being polluted by a Nayadi, one should bathe in seven streams and seven tanks, and then let out a few drops of blood from a little finger. Some believe that low caste people should not be seen by them on days when they have to be specially pure. The Ulladans and Parayans are mutually polluted by each others approach. I saw dozens of scars on the fingers of an old Ulladan which were the result of purification by blood-letting

* Touch tabu, eating tabu, and forms of personal address are good tests of caste grades. Applying these tests, it will be seen that Mohammedans and Christians, though they do not come under the Hindu social organization, are yet regarded by Hindus as socially inferior to Brahmins and Nayars, but superior to the other castes. The above generalization may however have some local exceptions, depending on the Hindu castes from which the Christians or Mohammedans are derived. As a rule, the Nayar is made impure by the touch of a Moplah or a Christian. The Nayar usually can address a Moplah or Christian by his personal name, whereas the latter has to add a honorific 'Nayar', etc., to the personal name. Christians and Mohammedans eat food cooked by Nayars, but Nayars do not eat food cooked by them. Christians and Muhammedans address members of castes below the Nayar only by their personal names. Religious groups that do not recognize caste are for historical and economic reasons given definite ranks in the framework of Malabar society. The Syrian Christians observe eating tabus just like any Hindu caste; so do the Mohammedans in some parts of Malabar as a result of the overwhelming influence of Hindu ideas that are grafted on their democratic faith.

Distance pollution between some important castes of Malabar can be represented diagrammatically as follows :—

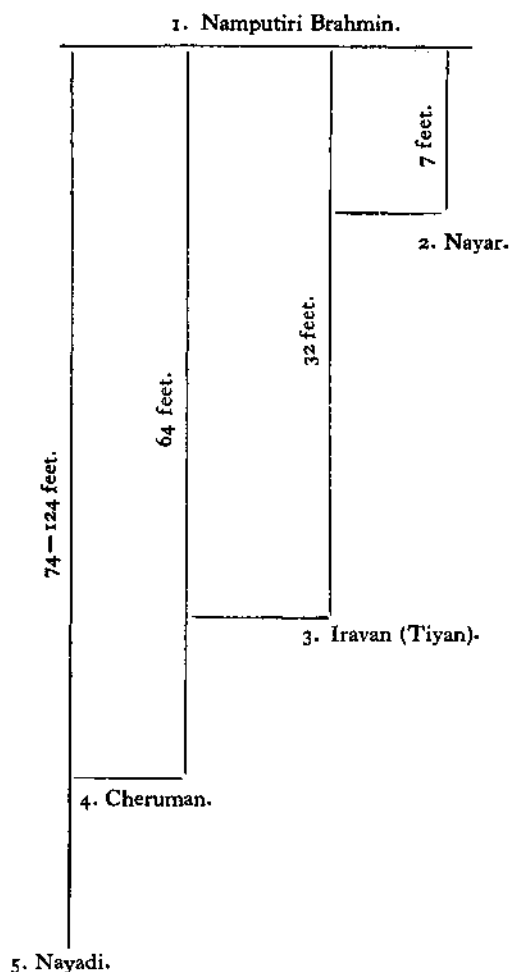

N.B.—The conventional polluting distances between the Nayar and Iravan, between the Iravan and Cheruman etc., can be calculated from the diagram.

In addition to the few castes mentioned in the above table, there are several others who are all polluted by the Nayadis. In going from place to place the latter have to avoid not only the men, women, and children of these various castes, but their dwellings, tanks, temples, and even the neighbourhood of streams in which they are bathing. If a Nayadi touches the water in which men of higher castes are bathing, the water loses its purificatory qualities so long as the Nayadi is in contact with it within sight of the bathers. The Nayadis are, therefore, always compelled to make devious detours from the usual roads and country paths in going from one place to another.

Ambivalence of Upper Caste Attitude towards the Nayadis.—In spite of the distance at which the Nayadis are kept by high caste Hindus, the latter are unanimous in holding that there is something noble about these despised men. They consider them purer than the Cherumans and the Parayans, because they eat cleaner food. The legends which give the Nayadis a Brahminical origin add sanctity to the caste ; they are regarded therefore as the Brahmins among the Chandalas (mean castes). They cannot be accused of any of the common vices. Though they drink toddy, they have not the means for injurious indulgence in it. Moreover, among the lower castes in Malabar drinking is not regarded as an anti-social matter, as it is among the upper castes. During particularly bad days some Nayadis are said to steal ears of paddy as they go across the fields. Except for this the Nayadis have a good reputation for honesty and straightforwardness.

Strange Notions about Nayadis.—Unhappily for the Nayadis they are, however, wrongly believed to steal high caste babies whenever they get hold of them, spit into their mouths so that they may be irretrievably defiled, and then bring them up as their own children. If a Nayadi happens to have a child lighter in complexion than is usual among their caste, it is smeared with oil and soot and exposed to the sun in order to make it grow darker ; if this is not done the parents run the risk of being suspected of kidnapping. The Nayadis are also suspected of occasionally carrying away high caste women. This suspicion has of course no foundation at all in truth. It seems to be a relic of an old custom relating not to Nayadis but to Parayans, Pulayans and Cherumans, of which we have the following description given by Barbosa :—“ These low class people during certain months of the year try as hard as they can to touch some of the Nayar women, as best as they may be able to manage it, and secretly by night to do them harm. So they go by night amongst the houses of Nayars to touch women ; and these take many precautions against this injury during these seasons. And if they touch any woman, even though no one sees it, and though there shall be no witnesses, she, the Naya rwoman herself publishes it, crying out, leaves her house, without choosing to enter it again, to damage her lineage. And what she most thinks of doing is to run to the house of some low people to hide herself, that her relations may not kill her as a remedy for what has happened or sell her to some strangers as they are accustomed to do. It is not necessary that there should be actual contact. It is enough if the person is hit by a stone or stick and then that person remains touched and lost.” * It used to be supposed that when various castes met annually at certain fighting grounds, such as Pallam and Ochira, low caste men were at liberty to seize high caste women and retain them. From this custom arose a popular error that if a Pulayan met a Sudra woman during the month *Kumbham* (February-March), he might seize her. Consequently this time of the year was called

* Barbosa, “ Description of the coasts of East Africa and Malabar in the beginning of the sixteenth century ” (Hakluyt Society Publications), p. 143.

pulapiti kalam or capture-by-Pulayan-season, i.e., the time during which a high caste woman might lose caste if a slave happened to throw a stone at her after sunset, though the motive of the kidnapping is not recorded anywhere.

Raman, the Nayadi "elder" of Kunnamkulam, told me how he and his people were penalised once on account of this superstition of the high castes. About thirty years ago a Namputiri Brahmin happened to see in Raman's household a young woman who was fairer than the other women. A young woman of the Brahmin's family had disappeared a few years ago and nobody knew where she had gone. The foolish Namputiri jumped to the conclusion that the woman he saw with the Nayadis was the same as the woman he had lost. Nayadis from all neighbouring villages were summoned by the Brahmin and were asked to explain how they happened to have a fair woman in their midst. The Nayadis explained that she was one of them, but the Namputiri considered that a very unsatisfactory answer and had them belaboured severely to extort confession. The old Nayadi proceeded to tell me that a few days after torturing him and his people, the Brahmin was troubled by bad dreams and that in order to expiate the sin of ill-treating the innocent men he gave them all a sumptuous feast.

The extreme degradation of the Nayadis is ascribed by some to their uncleanly habits. In the Cochin State Manual they are accused of eating the most dirty vermin and reptiles. This is an unjust accusation. They are also described as the laziest people in the State. The author of the Manual seems to forget that the Nayadis are beggars, not because of their laziness, but because they cannot get work. They are dirty, of course, but a people who cannot come near wells or tanks, and are forced to live on hill-slopes where even drinking water is scarce have few facilities for washing the few rags that they possess. In the dry season when water is scarce they have to drink water that is extremely impure. In spite of all these difficulties the Nayadis are as clean as other people of the same status in other parts of the Madras Presidency.

Some people say that the Nayadis eat the grubs that are found in the putrifying flesh of dead animals. They are said to keep the dead animal over a pot of boiling water, the steam making the grubs fall into the pot below. The Nayadis deny doing anything so dirty as this. Others ridicule the Nayadis by saying that among them the dowry for a woman consists of a hundred *palas* (leaf-sheaths of the areca palm). Kanakkans and Cherumans name their children sometimes as 'Nayadi' in order to ensure a longer lease of life to them. The god of death is supposed not to bother much about a child with such a mean name.

The Nayadis are sometimes ridiculed for the custom of *couvade* which they are supposed to observe and which is recorded by Thurston in his paper on the Nayadis (page 60, below). living Nayadi remembers anything that distantly resembles *couvade* and it seems probable that it has been wrongly attributed to them on account of its observance by other somewhat similar tribes.

Nayadi Settlements and Material Culture.

A Bird's-Eye View of Some Settlements.—The first Nayadis that I visited lived at Naduvattam near Karakkad (see plate xii) in Malabar. The country there is extremely rugged and hilly, most of the hills being bare; the valleys between the hills are under intense cultivation, and extend for miles. The high caste population live mostly far away in the more wooded parts. On the slopes of the hills bordering the rice fields are found the huts of poor Mohammedans and Cherumans. On the slope of a remote hill stood the solitary hut of our first Nayadi friend, Kandan, his wife and children (plate iii, fig. 4). This spot is more than half a mile away from the nearest Nayar habitation. Very near Kandan's hut was the hut of a Mohammedan farmer under whom Kandan worked occasionally. The boy, his brother-in-law (in the illustration he is seen with a sling on his left shoulder) looked after the farmer's cows and buffaloes and also watched his crops. Kandan's wife, Nili (the blue one), a quiet, fine-featured young woman, helped the lady of the farm. Nili's mother was in the habit of staying for long periods with her daughter as she was quite lonely. Both the women are seen in the photograph each carrying a child on her hip. These people were practically wiped out in the year 1933 by an epidemic of cholera, the boy, Kandan's brother-in-law, being the only survivor. Not far from Kandan's hut at the time of the visit, was a grove of mango trees under which were to be seen the ruins of the huts in which Kandan's father and uncles lived. When Kandan was a youngster, twenty of his relatives died of cholera. He was brought up by his mother's brother and when he was old enough, he came back to the old place, but did not go to the old huts. He built for himself a new hut about fifty yards away from the old site. Right on the summit of the hill there can still be seen the levelled spot bounded on two sides by big boulders where under a few palmyra leaves the stone and wooden representations of the gods and deceased relatives of Kandan were kept (plate vi, figs. 3, 4 and 5). The wooden figures were all being eaten by white ants. Though he was unable to house these figures properly and protect them, Kandan was quite unwilling to part with them. He was concerned very much about the harm that would befall us if we took the images away. For his own part, if he sold a figure or two to us, the gods, he thought, would not be angry with him, because they knew that he was poor. Of the dozen wooden figures only two were therefore obtained for the Madras Government Museum (plate vi, fig. 3). Of a once flourishing settlement nothing remains now except perhaps the stones representing the ancestors.¹

The second settlement visited was on the edge of an extensive rice field in the village of Pallatheri in the Palghat taluk. There were four huts within a fenced enclosure. This, however, is a new site, the original one having been deserted after an epidemic of cholera.

¹ Dozens of places where once there were Nayadis living have only local traditions as proof of the fact that these people have been more widely distributed than at present. About fifty years ago there was a Nayadi settlement, on the *Korikkodan* hill, in the Calicut taluk, according to the statement of the old village headman who had seen them on the hill near the spot where now are a dolmen and a curious boat-shaped cell in the laterite with a bridge across it.

The old huts were considered to be unlucky. Near the new huts, but outside the fence they have now a platform of earth on which a piece of granite representing *Uchchimahakali* (the demoness of cholera) is placed (plate vi, fig. 1), near the rows of stones representing the gods and ancestors.

At Kuzhalmannam (plate iii, fig. 5), Tenari, and Maruthrode, the Nayadi settlements consist of four or five huts huddled together in an enclosure with banana trees all round them giving a very pleasing aspect. Access to the enclosure is through an opening in the fencing across which two or three bamboo pieces are placed to form a crude stile. Hindu houses are found not far from these huts of the Nayadis. But in most parts of the Walluvanad taluk, the Nayadis are far away from the rest of the population, having not even the very low Cherumans in their neighbourhood. The Nayadi hut in the village of Kizhoor in the Walluvanad taluk stood on the outskirts of the jungle on the slope of a hill which was about four furlongs from the nearest Cheruman house. In the coastal villages, especially in predominantly Muslim areas, the Nayadis live without any segregation from the rest of the inhabitants.

The group of huts at Karakkad may be selected for description as a typical Nayadi settlement. After leaving the main road, one goes along the slope of a laterite hill and then crossing a few terraced fields sees these few huts perched on the hill slope amidst tall trees and shaded by banana clumps. The settlement is deserted except for children in the mornings. On summer evenings, the adults, both men and women, return to their huts after their begging rounds and may be found cooking in the open space in front of them. All the huts have some clean, well-swept, open space in front of and round them which is called *mirram*. It is here that the small families assemble in the evenings for cooking, eating, and chatting. Feasts in connexion with various domestic ceremonies are conducted in open sheds (*pandals*) built on the *mirram*. Men and women dance on festive occasions in these *pandals*. The *mirram* is levelled, plastered with clay and smeared with cowdung in the dry months after the rains. When they see strangers or officials approach, the Nayadis stand up and become afraid. They are specially afraid of the vaccinators who occasionally go among them to their utter consternation. The younger women retire to the backyard, while the older women remain where they are. They remain at a distance of several yards from the visitors lest the latter should be polluted. I had with me at the time of my first visit to the settlement not only the village officials, but also the owner of the hill on which the huts stood. When the landlord explained to them that I was a friendly visitor who wanted to know something about them, they were much relieved. While answering questions they have the mouth always covered by one hand. Once the ice was broken and the local men left me alone with the Nayadis they became quite easy in their manner and behaviour. I knew some of their relatives and when I spoke of my Nayadi friends elsewhere they told me that I was known to them and we became quite friendly.

Huts.—The huts are usually of the square type. In the coastal regions, plaited coconut leaves are used for thatching (plate v, fig. 2); in the interior villages palmyra leaves (plate iv, fig. 1; plate v, fig. 3) which are not plaited and also the straw of paddy are used for this purpose. The leaf of the coconut tree is split into two along the mid-rib and the leaflets of each half are separately woven. In thatching the leaf is placed with its under surface up, as the slightly incurved edges of the leaflets easily drain off water. The commonest material for fastening the leaves to the rafters is thin strips of the boat-shaped spathe covering the coconut inflorescence. This is soaked for some time in water to make it soft before it is torn up. The coconut leaf thatch has to be renewed every year. The leaves of the palmyra palm (*Borassus flabelliformis*) are more durable than those of the coconut tree and last for at least two years. Rice straw is used only occasionally. Handfuls of it are spread out on the frame work of the roof to about three to four inches thickness, beginning with the eave-end and then going up. Beams, etc., are very often made of bamboo poles or where wood is plentiful, branches of sufficient thickness and size are made use of without removing the bark. The walls of mud seldom come up to the level of the runners, but stop short in the middle. It is only in the best houses that there are complete walls. In the poorer huts, even a mud wall is absent, there being in its place, only a few plaited leaves fastened to short bamboo poles. The mud wall is made by lumps of clay being placed along the whole length after which the sides are levelled by hand. The ground plan of a typical example of the better class of houses is shown in plate x, fig. 1. The hatched part represents the wall of mud, and the dotted portions the low partitions inside. There are five pillars of wood (1—5 in the figure) with natural forks at the tip for supporting the roof, an extra one having been inserted to support the elongated eaves of one side, in addition to the usual one at each corner. Three additional pillars inside the house (6—8) support the ridge pole. The walls do not give any support to the roof. The plinth extends outside the walls on one side as an *ummaram* (9), on to which the main entrance to the house opens. In the first room (11) near the entrance there is a platform (10) in a corner. In the second room (12) there is an iron saucer with a sort of snout which serves as a lamp (16). In this room there is an earthen pot buried with its mouth flush with the floor in which rice and other food materials are stored up. This room is used by men. The next room (13) is for women. The kitchen (14) floor is at a lower level than the rest of the house. It has two doorways and a fire-place. The latter consists of a depression on the edge of which are three knobs of clay to bear the cooking vessels. Rafters placed at various angles run from the ridge pole to the runners on all sides and the eaves extend about three feet beyond the runners on one side and slightly less on the others. The floor is plastered with clay and periodically smeared with cowdung which allays the dust, gives the floor a pleasing colour and has a not unpleasant odour. Before every auspicious day the women-folk busy themselves beautifying the floor in this way and polishing it with a smooth piece of granite. Daily the floor is dusted with a broom made of

the midribs of the leaflets of the coconut palm and the rubbish from the *mirram* is swept with a smaller but stiffer broom of the same material. Cleaning and keeping the house in good condition are exclusively feminine tasks, and it is an insult for a boy or youth to be asked to do any of them. Similarly, beating with a broom is considered highly insulting. Girls learn to do the cleaning work in their houses as soon as they are strong enough to handle the tools; sweeping with the broom is one of the earliest adult jobs to which a girl puts her hands in childish play and in serious life.

Domestic Goods.—Furniture, as in the houses of all lower caste people in the same area, is extremely scanty. In only one Nayadi hut is there a wooden bench; the owner of this particular hut being the richest of all Nayadis (plate v, fig. 5, left), a man who earned a small fortune of a few hundred rupees by money-lending. The men sit on wooden planks about 18 inches long and 9 inches broad when they eat, but the women sit on the floor; guests, whether men or women are given similar planks or mats to sit on. These mats are made of plaited pandanus or palmyra leaves. The kitchen utensils are mostly of earthenware. Those for cooking rice are large in size. Two or three smaller ones serve for cooking curries, flat dish-like ones are for eating rice from, and smaller ones of the same shape for curries. Drinking cups are absent. Round earthenware waterpots are used for carrying water. Liquid food is eaten with ladles made of coconut shells with a thin splice of bamboo for handle which passes through two holes in the shell in a water-tight fashion. Leaf ladles are made of the leaves of the jack-fruit tree (*Artocarpus integrifolia*) by doubling one side of the leaf on itself and pinning the doubled part with a piece of the midrib of the palm leaf. For grinding condiments, there are rectangular granite slabs and barrel-shaped rollers, and wooden mortar and pestle for husking paddy. Cooking is done indoors during the rainy season. The simplest hearth consists of mere pieces of stones, three in number, placed so as to form a triangle, the space enclosed by the triangle being somewhat hollowed. The first step in the improvement of the hearth is the covering of the rude stones with clay and shaping them into short cylinders with hemispherical upper parts. The corner of the house in which cooking is done is always on the northern side in accordance with the usual practice with other castes also.

For sleeping Nayadis have mats of pandanus leaves. Pillows are unknown. Babies are given a rough cushion made of rags.

In every Nayadi hut large numbers of palm leaf umbrellas can be seen thrust on crude shelves. These umbrellas are part of the death-offerings which they receive from members of the higher castes (pp. 43-44). They are of immense use to the Nayadis when going about begging during the hot days of the dry months. Certain castes above the Nayadis, such as the Panans in some villages of South Malabar are not allowed to use umbrellas of this type (plate v, fig. 1). It is interesting that the Nayadis use it.

Of iron tools the Nayadis generally have only choppers, knives and sickles. Very few have axes. And only some of them have scrapers of iron for scraping coconut kernel.

Most of the Nayadis do not have wells from which to get good drinking water. Simple pits in the rice fields, ten or twelve feet deep, give them enough water except in the very dry part of the year. Buckets for drawing water from the wells are made of the broad leaf sheath of the areca palm by tucking and tying the two up-folded ends of a suitable length of it.

Mannu.—A general feature common to all Nayadi settlements is the *mannu* which is a hallowed spot under a large tree where can be seen circles or straight lines of upright stones (plates vi, vii, viii, figs. 2, 4, 5; 1; 2, 3, respectively). These constitute the material substratum of the religious life of the Nayadis, and are the visible link between the world of the living and that of the dead and of the supernatural. In some settlements the *mannu* is outside the fencing round the huts, in others inside.

Industries.—The Nayadis of the coastal villages make excellent rope of coconut fibre and those of the interior villages, of bark. Rope manufacture from the husk fibre of the coconut is a big industry on the Malabar coast in which thousands of men and women of various castes are employed; so no one particularly notices the work turned out by the Nayadis. They are too poor to buy the fibre and so go about collecting waste materials from the banks of the backwaters where the husks are soaked for rotting before they are beaten to get the fibre. Nayadis of the Government colony at Kunnankulam buy the raw materials from the merchants as it grows continually more and more difficult to get it free of payment. Such articles as were supplied to the villagers by the Nayadis are now brought to them by business agencies, but still the Nayadis manage to find a market for their goods, because they are better made and are sold at a cheaper price. They beat the husks collected into fibre and spin it into rope by twisting strands of it on the lateral aspect of the right thigh the skin of which becomes thickened and darkened as a result of the continued friction of the coarse fibre. The man or woman sits with the right leg extended and the thigh bared, and holding the strands of fibre in the left hand, rolls them on the thigh with the right hand.

In the interior villages where coconut fibre is not available, various barks are obtained from the jungles in long pieces, the soft outer part of which is beaten out with a heavy piece of wood. The inner fibre thus obtained is dried in the sun and teased into fine fibres which are spun into rope in exactly the same fashion as coconut fibre.

The special articles of Nayadi manufacture are ropes for drawing water from wells with areca leaf-base receptacles, collar ropes for cattle, ropes for securing cattle, slings (plate x, fig. 4) which are used as toys and for scaring birds, knitted balls for children (before rubber balls came into common use, they were in great demand, being made hollow so as to bounce),

rope-net bags for keeping vessels suspended (*uris*) (plate x, fig. 2) and ropes with a loop at one end used by hunters in restraining hounds (plate x, fig. 3). The Nayadis are good herbalists and are frequently employed to collect various medicinal plants which are obtained only in the jungles.

Before the introduction of soaps people used only vegetable preparations for removing the oils which they rub on their bodies before bathing. Even now when soap is used vegetable barks are often found more satisfactory. The barks of *Acacia concinna* and *Albezziella lebeck* are those most commonly used. The dried inner part of these barks when soaked in water produces a slimy fluid which has the property of removing oil and grease. The Nayadis get orders to supply bundles of soap barks from the rich people of the village who pay them in cash or in kind. Just before the national festivals of the people of Malabar, *Onam* and *Vishu*, in the months, July-August and April, the Nayadis are expected to present bundles of soap bark to all important houses in their villages and receive rice and other food-stuff from them. It is customary in Malabar for all castes to make presents to one another in this manner during festival seasons. The fact that the Nayadis also participate in the economic exchanges of the festive seasons, just as others do, is an indication of their having been well integrated into the Hindu Community. The carpenters and smiths each present the villagers with articles manufactured by them, the carpenter giving wooden planks and ladles, the blacksmith knives, the goldsmith cheap rings, etc. These people receive in return much more than what they give in value.

Another industry which brings the Nayadis a few rupees every year is the making of the resin of *Ailanthus excelsa* which is used as incense. The Nayadis make small cuts in the bark and when sufficient latex has exuded and hardened on the bark it is scraped and melted. Mohammedan merchants purchase the resin from them or the Nayadis sell it to likely purchasers of their village clientele. Before starting to collect the gum, the Nayadis follow the usual custom of invoking the blessing of their gods and ancestors on their enterprise.

Fire-Making.—Except for those living on the borders of the jungle present-day Nayadis have very little knowledge of old fashioned methods of making fire. The older men however remember that their fathers used to make fire by friction and that it was the only method of making fire they then knew. The Nayadis living near the forests occasionally use, like the Kadars, the flint and steel strike-a-light (*chakkumukki*) side by side with the match box which is difficult to keep dry in the extremely wet monsoon months. Of the methods based on friction between two pieces of wood, twirling or drill was the commonest method in South India, being used by the Todas, Irulas, and Yenadis, while the sawing method seems to have been characteristic of the more primitive among the hill-tribes such as the Paniyans and the Kadars. The Namputiris of Malabar still manufacture fire for their sacrifices by the twirling method, using sticks of the jack-fruit tree (*Artocarpus integrifolia*) and the peepal tree (*Ficus*

religiosa), similarly, the Todas use dry sticks of *Litsæa Wrightiana* for making fire in the dairy: but not even for religious purposes does the average Nayadi now have recourse to primitive modes of fire-making.

A specimen of Nayadi fire-making apparatus (plate viii, fig. 1; plate xi, fig. 2) in the Madras Museum (No. 1130) consists of two twigs of *Litsæa chinensis* with the bark peeled off. The hearth piece is the shorter of the two and is 34 c.m. long; the other is 42 c.m. long. The cavity scooped out in the hearth piece is 7 m.m. deep and the cut ends of the very coarse longitudinal fibres of the twig are visible on the sides of the cavity. The hemispherical tip of the twirling rod fits closely into the cavity. By actual trial I found that red hot wood dust could be produced in less than seven or eight minutes. Thurston records that the Nayadis do not 'like the Todas, put powdered charcoal into the cavity, but ignite the cloth rag by means of the red hot wood dust produced by the friction'.* When out hunting, the Nayadis and other hunters of the country skirting the jungles make fire by the drill method. At a demonstration of fire-making which I witnessed, freshly cut twigs of *Lantana camerala* were used as both the hearth piece and the twirling rod. These twigs were quite fresh and moist. A shallow socket was cut in the hearth piece with a knife and the tip of the twirling rod was shaped to fit into the socket. An old cotton rag was placed below the socket, the hearth piece was held tightly in position under the feet and the rod was twirled between the palms beginning at the top end, the hands being carried down as the twirling proceeded. It took less than four minutes to make the rag smoke. It is only the men that know how to make fire in this manner.

Rat-Traps.—The Nayadis consider the rat a delicious dish and can be found smoking and digging up rats from their holes. In some places they use a bow and piston trap for catching rats. The trap (plate xi, fig. 1) consists of a cylinder of bamboo (*a*) with a stout solid piston rod of wood (*b*) kept between the string and stave of a bow. A catch-string is passed through the four holes (*eeee*) along the borders of the rectangular aperture on the side of the cylinder. The lower end of the piston rests on the upper horizontal section of the catch-string and presses down on it on account of the tension of the bow-string on its upper end. Bait in the form of dried prawns is put at the bottom of the cylinder. The rat gets into the cylinder through the rectangular hole marked (*eeee*) in the diagram, but its way down is intercepted by the lower horizontal section of the catch-string (shown in the figure by parallel dotted lines) which it bites and as it snaps, the piston which is no longer kept in position on its rest is pushed down violently by the tension of the bow-string. The rat is crushed between the descending lower end of the piston and the bottom (the nodal septum) of the bamboo cylinder.

Agriculture and Live-stock.—Only a couple of Nayadis are engaged in agriculture, but they have no cattle for ploughing and have to borrow them. Some others have each a

* Thurston, "Castes and Tribes of South India", Vol. V, page 278.

goat or two and sometimes a cow, but such people are exceptions, not the rule. All Nayadis have a few hens and cocks as they are cheap and easily fed. They are kept in large round baskets or in small cellars under the *ummarams* (raised platforms) round their huts.

The Nayadi thus has little of the material things of this world, neither land nor raw materials for his small industrial pursuits. As the pressure of population grows, the natural resources of the forests to which he has some access get into the hands of private owners which progressively adds to the dependence of the Nayadi on charity. He lives on the irreducible minimum, having barely clothes to cover his nakedness, a mat to sleep on, and a simple hut made by himself for shelter.

Social Organization.

Like other serf castes of Malabar the Nayadis describe themselves as 'the Nayadis of such and such a *Tampuran* or local land-lord', meaning the one whose dependants they are and on whose land they have their habitations. In the case of the Cherumans, who are agricultural labourers, the attachment to the land and to the landlord is particularly intimate, but with the Nayadis, the tie is loose, and results from their following the practice of their neighbours. The landlord after whom a particular group of the Nayadis name themselves is usually the most influential man of the locality and the natural leader of the population to whom not only the Nayadis but also members of other castes look up for help and protection and whose orders they obey.

Territorial Division.—Each kinship and family group have their area (*desam*) for begging clearly delimited by well-marked boundaries. The owner of a begging division mortgages or sells his right in the area in times of need and several instances have come to my notice of these divisions changing hands. Beggar tribes in Mysore have, in a similar fashion, divided their districts into parishes for begging purposes. Many of the jungle tribes have their rights over the forest produce settled and distributed among various kinship groups. Any intrusion into another man's area is resented and the intruder violently chastised, besides suffering ridicule and loss of kudos. The development of some degree of private ownership among the jungle tribes begins with the division of hunting and collecting areas, and that such division characterises even the most primitive of the tribes is borne testimony to by its existence among the Paniyans of the Wynad area in the Malabar district.

Clans (Illams).—The most important sociological division of the Nayadis is known as the *illam* (house) or *Kuttam* (horde) which corresponds to the *tarvad* of other castes. *Illam* descent is patrilineal, so that members of a settlement are generally of the same *illam*. Sometimes members of the same *illam* are found distributed in three or four villages. In Ponnani and the adjacent villages of Cochin women married into a group are made members of the husband's clan by a process known as *illam talakkal* (getting attached to the *illam*). In other places women do not change their *illma* on marriage.

Since persons having the same *illam* are regarded as blood-relatives between whom marriage is prohibited, the *illam* is an exogamous group that prevents marriage within it. Even if there is considerable distance separating groups that have the same *illam*, they maintain social intercourse with one another by taking part in important ceremonies, and keep the kinship tie unbroken. When a Nayadi refers to kinship groups each group is labelled by the *illam* or clan name.

The word *illam* in modern Malayalam means "house", and specifically the house of a Nampūtiri Brahmin. In Malabar the houses of various classes have particular names. Some people, therefore, think that the fact of having *illams* can be regarded as a proof of the Brahminical origin of the Nayadis. This argument, however, is not sound, for several castes including carpenters, fishermen, blacksmiths, and washermen are also organized into *illams*. Though in everyday language *illam* means a Brahmin house, in the sociology of Malabar it is common to all castes both upper and lower. Since the Nayadis are numerically small it has not been necessary for them to make their social organization complex. For big castes like the Iravans there are exogamous *tarvads* or clans that are patrilineally inherited and for the only purpose of regulating marriage there are exogamous matrilineal divisions, which thus act as a double check on a person's choice of a spouse. The Nayadis have at present contented themselves with only the first of these two kinds of social segmentation.

¹ In the history of many castes in Malabar one notices a change from patriliney to matriliney. The Nampūtiris of North Malabar, originally patrilineal, turned matrilineal; many Kshatriya families in Malabar originally of patrilineal stock are now matrilineal. Similarly, in the Palghat taluk, patrilineal Tamil castes have become matrilineal like the Nayars and are almost indistinguishable from them. Unless we have definite and reliable knowledge of the history of each caste, it is not possible to deal with the evolutionary aspect of their social organization.

On page 20 of "Social Organization" Dr. Rivers says that it will be correct to call the *tarvad* a joint family. In some *tarvads* it is not possible to trace the relationships between all the various families that bear the common family name. Except the family name common to all, there is no other bond between them. Smaller *tarvads* with only a few individual families bearing the common *tarvad* name resemble a joint family, but when a *tarvad* grows large and diffuse, it would be a mistake to regard it as anything other than a clan. In countries where genealogical memory is better developed than in Malabar, a *tarvad* might perhaps be regarded as a huge joint family. When a *tarvad* in Malabar subdivides it is customary for each of its new branches to take new names, sometimes double-barrelled, involving combination of a new name with the old one. But sometimes the new name only is used, the old one being dropped. Each *tarvad* usually has several branches, living in separate households and with their estates separately owned. Except in some of the most aristocratic *tarvads* there is no property common to all its branches. In the same locality households having the same *tarvad* name do not necessarily observe death-pollution. It is, in my opinion, more correct to regard the *tarvad* as a clan rather than a joint family, because the common name binds numerous extended families together. A joint family is "a group of families" "living together" according to the definition in "Notes and Queries" (5th edition). A typical *tarvad* is a group of joint families, not a group of single families.

The following are the *illams* of the Nayadis in the Ponnani taluk and the adjacent villages of Cochin. This was obtained by enquiries made at the Government Colony at Kunnankulam where there are families belonging to the *Teruvattil illam*. I am consequently unable to give the names of villages with which the different *illams* are connected :—

1. Achcharan.
2. Aryattiri.
3. Irikkan.
4. Kannanan.
5. Koyikkalan.
6. Talappil.
7. Teruvattil.

There is some difference in the status of these *illams*, No. 7 being regarded as the highest and No. 5 as the lowest. The word "Teruvattil" is a corrupt form of "Svarupattil" (in the royal house) which is used for families of ruling chiefs. Teruvattil is the clan name of the Nayadi chief Raman of Kunnankulam Colony (*see p. 40*). Regarding the lowest *illam*, Koyikkalan, it is doubtful whether the Nayadi way of pronouncing the word is correct; as pronounced by them it means "he of the leg of the fowl" which makes no sense at all. It is probable that the correct name of the clan may have been Koyikkalon which means "he who is attached to the palace", that is, palace menial. All the names except the fifth and seventh are probably place names. The name Kannanan is used by the Iravans for one of their *illams*.

The names of *illams* in the Walluvanad taluk with the names of villages where they occur are given below :—

Illams.				Villages.
1. Chelakkaran	Vayinur.
2. Kariman	Kulukallur.
3. Kotankatan	Varod.
4. Koyalpataran	Chelakkara.
5. Kurrikatan	Marayamangalam, Chalavara.
6. Patan	Perur.
7. Pataran	Thazhekkode, Vadanamkurissi, Kizhoor, Karakkad.
8. Pattikatan	Mankara.
9. Pilavariyan	Nemmini, Tiruvazhamkunnu.
10. Vittikatan	Katampazhiyur, Kumaramputtur, Karimpuzha.

The termination in 5, 8 and 10, means forest. The same termination is common to family names of higher castes. Most of the other names are geographical. There is nothing in any of these names to suggest totemism.

The chart on the opposite page shows how *illams* are linked generation after generation by cross-cousin marriages. The families on the basis of whose marriage ties the chart is made belong to Walluvanad and Cochin State. The exchange of women from one group to the other is well brought out in the chart. The scheme and the symbols used are those suggested by the Sociological Research Committee of the Royal Anthropological Institute (*Man*, 141, 1932). The marriage coupling bar is joined vertically to the base of the symbols, a square for male and a circle for female. No. 7 in the chart stands for Pataran which is the seventh in the list of *illams* in the Walluvanad taluk, 4 for Koyalpataran, and 3 for Kotankatan.

Joint Family.—The Nayadis live in joint families which consist of father, mother, married sons and their wives, and unmarried daughters. As the son's family grows bigger he may leave the parents and set up a new household, leaving the father and mother with his younger brothers. Unless the father and mother are very feeble and unable to earn their livelihood, the son who has thus set up a new household does not render any help to them. The husband's mother has charge of the internal arrangement and organization of the household; it is she who has to serve the food, give orders and see that they are obeyed by the women of the house (her unmarried daughters and her daughters-in-law) and her grand-children. Between the daughters and the daughters-in-law there is apt to be a very strained relationship, a disharmony tending towards the break up of the joint family. The Nayadi joint family does not, therefore, grow to the proportion of that of the matrilineal Nayars where the children of several sisters live together, and marriage being matrilocal and the husband a visitor, the fissiparous tendency of joint families due to the introduction of strangers by marriage into the family circle is avoided.

In any Nayadi settlement the members of the several households are as a rule closely related to one another and the eldest of the kinship group exercises control over the rest, co-ordinating their activities when some common enterprise requires concerted action. When, for example, the ceremonies in honour of the gods and the dead are to be conducted, he organizes them and fixes each person's contribution to the expenses and his function in the activities in connexion with the celebrations. He acts as the chief celebrant for such communal celebrations, and also as the shaman. In short he corresponds to the *Karanavan* of a Nayar household.

Inangu, Sesham and Bandhu.—If the kinship situation of any ceremony or feast of the Nayadis is studied, it will be found that the agnates of a person and his relatives by marriage are in separate groups. The agnatic group is known as the *seshakkar* and during a death ceremony they are known as the *pulakkar*. By *seshakkar* is meant those that have the *sesham*, which is a piece cut off from the shroud swathed round the dead body and used by the mourners during the rites in honour of the dead (*see* below, p. 65). The whole group

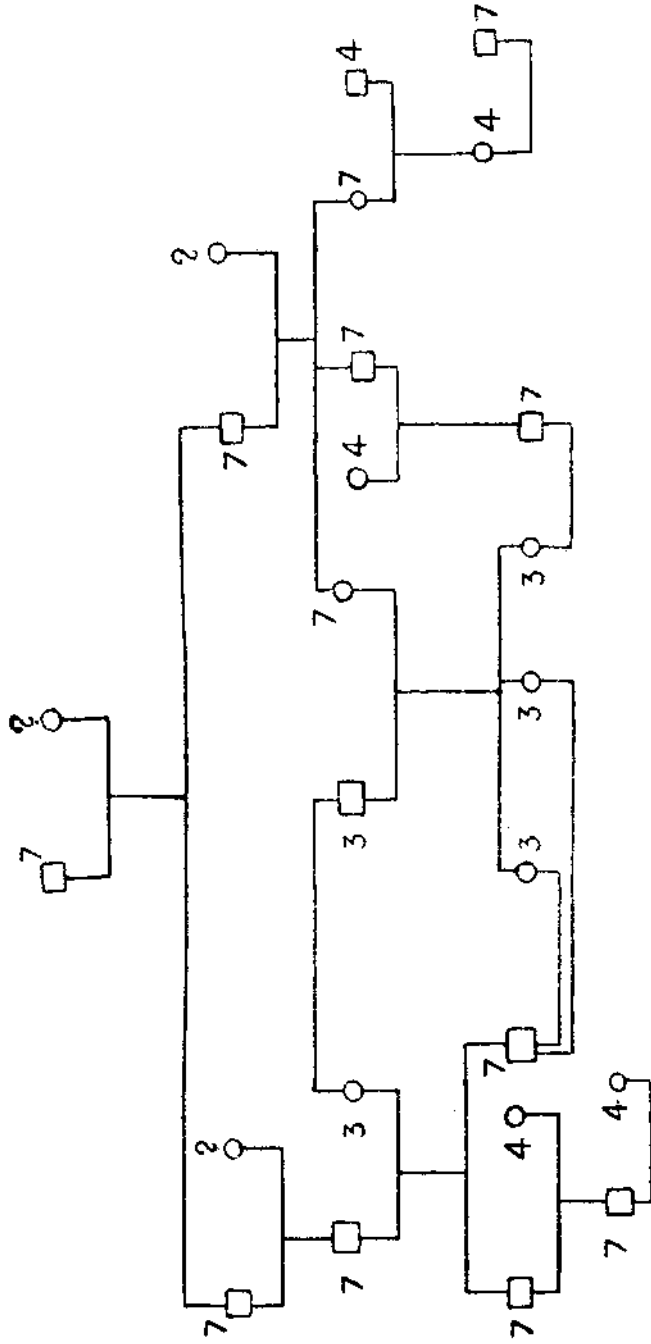

of relatives by marriage is known as the *bandhukkal*. People who are quite unrelated, of whom very few will be present, are known as *jatikkar* (men of the caste). Another word used loosely as synonymous with *bandhukkal* is *Inangar* (plural of *Inangan*). Literally *Inangan* means a chum and a group of such constitute an *inangu*.* The *Inangan* functions as priest at death and marriage ceremonies and though any family from among the relatives by marriage or from an unrelated group can serve as *inangu*, yet, in practice, only members of a specially chosen family act as *Inangans* on the strength of a close marriage tie. *Inangans* help in the burial of the dead, officiate on various occasions as the masters of ceremonies and also as cooks when the agnates are interdicted from cooking on account of death pollution. Women married into a family in the Walluvanad taluk are not affected by death pollution in their husbands' household except when the deceased is either own husband or child. *Inangans* act as the barbers for the mourners on the last day of the death pollution prior to its ceremonial removal. Among some castes slightly higher than the Nayadis, barbers are a separate sub-caste with a lower status than the main body of the caste. The system obtaining among the Nayadis of mobile groups of people on special occasions performing special duties may represent an early stage in the development of professional subcastes.

The *Inangan*, therefore, is both an incipient priest and barber in one. Among other lower castes also, e.g., the Iravans, the *Inangan* is the priest. The Brahmin priest of the Vedic times was priest and sorcerer combined and only later the two functions became separated. As castes grow more complex, functional subcastes originate and in Malabar the process is observable in its different stages. Taking only the lower castes into consideration, the lowest of them, the Nayadis, have the *Inangan*, an ordinary member of the community officiating as the priest and barber. Among the Iravans, the highest of the lower castes, the *Inangan* is the priest as he is among the Nayadis, but he is not the barber, as a sub-caste takes upon it this special function. There is no intermarriage or commensalism between the main body of the Iravans and its offshoot, the Iravan barber. Among the Pulayans, an intermediate caste between the Iravans and the Nayadis, there are five septs, Kolamari, Vettukar, Vettuvan, Tandan, and Adutton in the order of social precedence, the last mentioned being a very insignificant group that serves the other four as priest-barber. When a local Adutton family becomes extinct, a woman of the Kolamari sept is given in marriage to a man of the Vettukar sept and the children born of them fill the place of the extinct family of barbers and constitute the fifth sept.

In the above digression on barber-priests and the formation of functional subcastes reference was made to the Brahmin priest, but there is a fundamental difference between

* For details of the *inangu* system among the Nayars see the author's note *Man*, 337, 1932. The *Inangan* among other castes in Malabar should be unrelated by even indirect marriage ties. When marriage takes place between two families that are mutually *inangu*, they have both to look for other *Inangans* for their domestic ceremonies.

Husband's sister's child	<i>marumakan.</i>
Mother's brother's child	<i>machchunan</i> or <i>machchunihchi.</i>
Father's sister's child	Do.
Mother's elder sister	<i>valiyamma.</i>
Sister's child (w.s.)	same as own child.

When addressing elders, only the proper relationship terms should, strictly speaking, be used but in practice this is difficult because of the multiplicity of persons to whom each term of address applies. In order to overcome this difficulty, the relationship term is usually suffixed to the personal names of relatives other than own parents and grandparents, and sometimes elder brothers and sisters. Addressing a person exclusively by the relationship term indicates intimacy and endearment.

Morphology of Relationship among Nayadis and other Lower Castes of Malabar.—Relationship terms and relationship usages among the Nayadis conform to the usual types that obtain among the lower patrilineal castes of Malabar with some slight modifications. Fewer relationship terms exist among the lower castes of the Malabar coast than among the corresponding Tamil castes. Thus, for instance, there are no separate terms for father's sister and mother's brother's wife. Obligatory cross-cousin marriage leads to the mother's brother and the wife's father being known by the same term, as they always refer to the same person. Privileges and functions of relatives are, according to Rivers, better defined among people who possess a more complex system of relationship terms. This generalisation seems to hold good in the case of the Nayadis, because, in keeping with the simple kinship terms, the allocation of functions is also in a very rudimentary state, *e.g.*, the important ceremony of naming of a child may be done by the mother's brother or the father's sister.

Persons who are not related at all address each other as if they were related; if they are of the same age approximately, they address each other as brothers or sisters; if of different generations, the younger person addresses the older as uncle and if still older, as grandfather. This form of etiquette is prevalent among most of the lower patrilineal castes of Malabar, but not among the strictly matrilineal castes who use the personal name followed by the caste name.

The understanding of the linguistic and social significance of the kinship terms used by the Nayadis necessitates an understanding of the terms in general use by lower castes round about them in Malabar with which they are practically identical. A brief account of the more important of these terms must therefore now be given.

FATHER AND MOTHER.—There is only one term *amma* for mother. There are two terms *achchan* and *appan* for father. The latter is used by the Tamils and by the lower castes of Malabar, but the former is peculiar to the matrilineal people of Malabar and is

being adopted by others in preference to their own term, *appan*. It is curious, however, that some patrilineal people who use the term *appan* for the father uses the term *achchan* for elder brother. I am unable to offer any explanation for this. There is no doubt, however, that, of the two, *appan* is the older term. *Achchan* is a Pali term meaning "noble" (Aryan) and it may be likely that the children of hypergamous unions between the Brahmin immigrants into Malabar and native women used this term for their Aryan fathers and later it came to be used by others also by the process of diffusion by prestige.

BROTHER AND SISTER.—The Tamil and Malayalam terms for brother and sister throw some light on linguistic usages in the former country. Literary evidence shows that the Tamil terms *annan* for elder brother, *tampi* for younger brother, *akka* for elder sister, and *tankai* for younger sister were used by the people of Malabar just as the Tamils do now. These terms were replaced in popular usage by terms derived from Sanskrit (see the list of relationship terms). In Tamil no special term indicating the sex of the speaker is used by the sister in addressing a brother or vice versa, while in Malayalam there are terms to distinguish the age and sex of the speaker; when a sister addresses a brother, if the latter is the older, she uses the term *annala*, and when a younger brother addresses an elder sister, he uses the term *pennal*. These terms are honorific plurals meaning respectively, men-folk and women-folk. They are regarded as smacking of primitiveness by some people and therefore are being given up.

FATHER'S BROTHER, MOTHER'S SISTER AND THEIR CHILDREN.—As in Polynesia, "the father's brother receives the same designation as the father, his wife as the mother, and his children as own brothers and sisters." Rank according to age is indicated by adding "big" or "small" before "father" and "mother." So terms like "big father," "small father," "big mother," and "small mother" result, as in other classificatory systems. Societies in which levirate is unknown also use these terms, as for example, the Nayars. Own brothers and sisters are not distinguishable from the children of the father's brothers or mother's sisters in any linguistic manner, such distinction being only sociological.

MOTHER'S BROTHER, FATHER'S SISTER AND THEIR CHILDREN.—Mother's brother and father's sister's husband are both termed *ammaman*, shortened sometimes into *maman*. All the patrilineal people of Malabar use the same term for these relatives. But most matrilineal castes have no term for the father's sister's husband as he is far removed from one's kinship circle, and therefore, by the term *ammaman* only the mother's brother is designated. Repeated and obligatory cross-cousin marriage makes the mother's brother, father's sister's husband, and the father-in-law identical.

We have seen that parallel cousins are addressed as brothers and sisters. Cross-cousins are also addressed as brothers and sisters, but in description they are referred to as *machchunan* (for males) and *machchunichchi* (for females). Since *machchunans* are prospective brothers-in-law, sometimes they are designated as *aliyan* (wife's brother or sister's husband), and the *machchunichchi* as *nattun* (husband's sister or brother's wife). According to the Tamil Lexicon the word "*aliyan*" means "a beloved, sincere obliging friend". The relationship between brothers-in-law is well described by this term as it clearly expresses the intimate bonds of kinship obligations between persons so connected. An *aliyan* is consulted on all important matters, and it is on him the responsibility of looking after a man's widow and children falls in the event of his death. The best things are always set apart for the *aliyan* and he is the best and the most honoured of all guests. Two Malayalam sayings translated below crystallize in a few words the nature of the brother-in-law relationship :

(1) "When one dives for pearls the *aliyan* must hold the rope." It shows that a brother-in-law is the most trusted person.

(2) "Curry made of the head of the mackerel should not be given even to the *aliyan*." Head of the mackerel is regarded by fish-eating Malayalis as a very great delicacy. It is such a nice dish that one feels tempted to eat it without sharing it with any one, even one's brother-in-law to whom the best things are usually given.

A man addresses his elder brother's wife as *jyeshthatti*, while the wife of a younger brother addresses him just as the younger brother himself does. There is no avoidance between a man and his mother-in-law among the Nayadis, though it is common among the hill-tribes such as the Kadars. A woman addresses her elder sister's husband as *jyeshthan* and her husband's elder brother's wife as *jyeshthatti*, i.e., just as her husband would address her. A mother-in-law is called *ammayi* whether or not she is own father's sister or mother's brother's wife. There is always considerable friction between a mother-in-law and her daughter-in-law. Here again proverbs may be cited to explain synoptically the relationship attitude between these two relatives :

1. "What the *ammayi* (mother-in-law) broke is a *man-chatti* (an earthen plate) ; what the *marumakal* (daughter-in-law) broke is a *pon-chatti* (gold plate)." As the mother-in-law most often lives with the son and daughter-in-law, the two women work together ; earthenware vessels which they use may sometimes be broken accidentally, but always the mother-in-law makes light of her faults, but exaggerates those of her daughter-in-law.

2. "Like the daughter-in-law weeping for her dead mother-in-law." When someone acts in a flagrantly insincere manner, this expression is used. These two relatives have no love lost between them and when one weeps over the other, it is an instance of patent hypocrisy.

3. "The mother-in-law wants to enjoy the grief of the daughter-in-law even if she has to risk her son's death for that." The daughter-in-law is disliked to such an extent that to spite her the mother-in-law is prepared to commit any atrocity and herself suffer. The proverb drives the point home by exaggerating it.

The position of a mother is tragically expressed in another proverb which is also relevant in this context :

"A daughter is unwilling to grind some bran for her own mother, but for another mother (i.e., the mother-in-law) she grinds even iron." Daughters who are tenderly looked after and little used to hard work in their own parental homes are made to do hard jobs in a merciless manner in their husband's houses by the mothers-in-law.

The relationship terms discussed above have the same significance for the Nayadis as for others of the lower castes. While various castes differ among themselves to a certain extent in most cultural matters, such difference is least in the matter of relationship terms. The Nayadis use terms derived from Sanskrit though they are far removed from the Aryan culture of which such terms are a part, which naturally leads us to the conclusion that the Nayadis may have borrowed them from more Aryanised castes. I have given examples in the preceding paragraphs which show that relationship terms do not have in Malabar the fixity and unchangeableness that Morgan thought they had (*see* Morgan, "Ancient Society").

Relationship Attitude in the Nayadi Family—PARENTS AND CHILDREN.—An outsider is often struck by the free and easy manner in which parents and children behave towards each other. Observing the absence of formalities within the family, upper caste critics are often heard to say that the Nayadis have no respect for their elders. Among the upper castes and some of the lower castes, a son or daughter is not to sit in the presence of the father. This and other rules of decorum that the upper castes follow are absent in Nayadi society. Young children are brought up in an exceedingly indulgent manner, as children are not regarded as a responsibility, but as an investment (*see* the Section on Domestic Ceremonies and Customs, page 62). The mother continues to suckle a baby till another is born or sometimes till it is four or five years old. Their begging tours however necessitates the parents leaving the younger children in the charge of the elder ones, who are thus saddled early in life with heavy responsibilities. The bonds of love and duty between the children themselves on the one hand, and between the parents and children, on the other, do not suffer, as they do very often, when the children grow and have their own families. Complaints against sons that they have shirked their duty to their parents are extremely rare among the Nayadis.

HUSBAND AND WIFE.—Being already related before the marriage, the husband and wife among the Nayadis do not meet each other as strangers on the day of the marriage, as the bride and bridegroom do among other castes in the Malabar country. Up to the time of

their marriage they would be addressing each other as brother and sister, but these terms of address are dropped from the time of the marriage, or to be more precise, from the time of the marriage negotiations. Very often young girls grow up knowing who will be their future husbands. Between husband and wife there is no term of address, except the term 'eti' which is only a vocative for female inferiors which the man uses to attract the wife's notice. When they are not quite accustomed to each other, even this term will not be used, but mere sounds which would mean 'you there,' or 'there.' Young husbands feel 'shame' when they are asked to name their wives when their elders are present near. There is no tabu against uttering one's spouse's name, though the existence of such a tabu is well known for other castes among whom wives are not to utter the husbands' names whatever the circumstances are. Among the Ulladans, women observe the tabu against pronouncing the name of the husbands in a very strict manner. They do not even pronounce nouns that have the same initial syllables as their husbands' names. (If the husband's name is Chakkan his wife will not mention *Chakka*, the Malayalam word for the jack fruit, but will use some circumlocutory expression to convey her idea.) Husband and wife among the Nayadis go about together and talk freely in public. This kind of behaviour between husband and wife is considered 'shameful' by the higher castes among whom a high degree of reserve is maintained between man and wife when they are in public. When a Nayadi goes to the toddy shop, he is accompanied by his wife, and Malayalis who see Westerners going often in public with their wives compare them to the Nayadis and the Cherumans. The vernacular word for 'wife' is not used by the men when they refer to their wives, but merely the term '*Nayadichi*' (which means female of the Nayadis) or simply, '*pennu*' (woman). The woman in her turn refers to her husband as "my Nayadi."

Application of the Genealogical Method.—Genealogies of only a few families were collected, because the genealogical memory of the Nayadis was found to be poor on the whole. Few people remembered anything about ancestors more remote than the grandfather. The following observation on the question of the 'ancestral tree' is found in the Malabar Marriage Commission Report :—

"It must be borne in mind, as a matter of fact, that the Nayars and Tiyans do not maintain ancestral trees and Mr. Winterbotham¹ believes as a result of his *jamabandhi*² experience that there are very few *marumakkattayam* families who can ascertain the pedigree of themselves, and their relatives for more than three generations." If that is the case among two advanced castes in Malabar, it is no wonder that the Nayadis do not have good records of their ancestors and thus disappoint the anthropologist who approaches the study of the social organisation of the Nayadis with the methodological tool supplied by Rivers.

¹ Collector of Malabar and member of the Malabar Marriage Commission.

² Revenue collection.

³ Matrilineal.

The genealogical tables collected show that people usually marry cross-cousins, and only in their absence, classificatory cross-cousins. Married couples usually have on an average seven or eight children. Remarriages are rare, widows being usually taken over by the brothers of their deceased husbands.

Some instances are known of one person transferring his wife to another, a brother or parallel cousin. For example, in the village of Kizhoor there are two parallel cousins, Kunjan and Sankaran who are the sons of two brothers. Kunjan being a clever fellow married earlier than Sankaran who was slow, quiet, and different from the others in being a tee-totaller. Sankaran had great difficulty in getting a wife. After some trouble a bride was pitched upon for Sankaran and a day for the marriage fixed. When the bridegroom's party went to fetch the girl, her relatives pleaded ignorance of the arrangement for marriage, and so they had to return disappointed. Kunjan, the spirited man that he was, managed to get another girl to replace the one they were refused, but instead of Sankaran, the bridegroom, marrying her, she was married to Kunjan, and his wife, Kali, who had two children, one by Kunjan, and the other by a previous husband, was transferred to Sankaran. This peculiar arrangement had to be made, because the relatives thought that Sankaran being so meek would not be able to control the new bride, whereas Kali, the wife of Kunjan, was a very docile woman and was sure of becoming an obedient wife to Sankaran. This Kali's first husband was a clan brother of both Kunjan and Sankaran, all of them belonging to the Pataril *illam*.

Chieftaincy.—In Ponnani and the adjoining villages of Cochin State the office of the chief or *Mutta* Nayadi is still a living institution and is hereditary. Raman, the *Mutta* Nayadi of the Kunnankulam area, is about seventy years old; he and his sister Sita were my chief informants on his rather vague duties. The *Mutta* Nayadi settles disputes between his men and has authority to punish them either by fines or by blows on their back. During the festive seasons the *Mutta* Nayadi is given presents by all his men. The chief's *illam* is known as the 'royal house' and this *illam* is supposed to be the highest of all. The chief's father-in-law thus belongs to an inferior clan and has therefore to stand up and show respect to his son-in-law.

The installation of a new *Mutta* Nayadi takes place on the anniversary of the death of the former chief. The ceremony is performed in two halves, one at the local temple and the other in the house. All the Nayadis of "the eighteen *Nadus*" (what these eighteen *Nadus* or districts are, no one now seems to know) assemble in the neighbourhood of the Kakkad temple near Kunnankulam town and get some water and flowers from the Brahmin priest. The water is sprinkled on the old chief's son to purify him, after which the flowers are thrown on his head. Then the affines of the chief's family throw grains of rice on him, saying as they do so, "The headship of the Nayadis of the Talappulli

country (a taluk of the Cochin State) is this person's." The spirit of the deceased *Mutta* Nayadi is then supposed to come upon him, his whole body begins to shake from head to foot, and the deceased chief proclaims his satisfaction through him.¹ The party then return to a shed built for the purpose in front of the chief's hut where they partake of a feast. The remaining part of the ceremony takes place at night. A branch of *palakap-payyani* tree (*Oroxylum indicum*) is brought from the jungle by the maternal kinsmen or *Inangans* and is planted in the centre of the shed. A bundle containing rice, pepper, some copper coins, betel leaves, and tobacco is tied at the tip of the branch, and some rice and flowers are heaped near the bottom. The heir to the chieftaincy circumambulates round the branch and climbs to the top of it, and as he does so, the *Inangans* throw up the rice and flowers on him saying, "The lord of the Cochin country is about to get his 'elder-ship.' The *Unni* (a young person of rank) is about to get his 'elder-ship.' Let him get the *kuru* (rank) of the grandfather." The new chief now gets down bringing with him the bundle from the top of the branch. The affines carry the branch with the new chief riding on it, after which it is thrown into the water.

"Throwing rice" is an essential part of the installation ceremony of the rulers and potentates in Malabar. When a Nayadi elder is installed the affines acclaim him as the Zamorin or the Rajah of Cochin, which he is not. The formulæ uttered show that the Nayadis are imitating their superiors and copy the bare outline of their rituals in connexion with the investiture of royalty.

The shadow pole ceremony on the anniversary day of a man's death described in the section on Domestic Ceremonies (pp. 68 ff.) and the installation ceremony at Kunnankulam bear close resemblance to each other. It is likely that in chiefly families the death anniversary and the installation are combined.

No definite chieftaincy obtains among the Nayadis of Walluvanad and Palghat. In the former, one of the officiants at ceremonies on the anniversary day of a man's death is known as the *Samutiri* (the name in Malayalam of the Zamorin of Calicut, ruler of Malabar at the time of the coming of the Portuguese to India), and another as *Melkoyma* or Overlord. These are mere ceremonial names now and it is unlikely that they ever meant anything more.

Begging.

Charity and the Begging Castes.—From descriptions of the way in which the Nayadis are kept at a distance by the rest of the Hindus, it might be thought the latter are wantonly cruel to an inoffensive section of their fellow beings. The fact is, however, that both the peoples concerned are unconscious of the oppressiveness of the traditional norms of behaviour involved in the observance of untouchability. The Nayadis live chiefly on what they receive

¹ Trance phenomenon among these people has not been studied in any detail.

as alms on various occasions from the rest of the Hindu community. It is the privilege and right of the Nayadis to beg and it is the duty of the others to give. Except for a few of the younger generation of Nayadis none feels that it is derogatory to be a beggar. Charity has been institutionalized and woven into the fabric of Hindu society with the result that much of the emotional play which is at the root of charity in the west is non-existent here—which has led to the belief that there is no sympathy in Indian charity. When charity is left to the sentiment of the group of givers, it is a risky kind of dependence for the group of recipients. But when it is grafted in the religious faith of the donors, the lot of the beggars is less derogatory and less precarious. The Pulluvans in Malabar are another caste of beggars who are also the priests for the lower castes when they celebrate serpent rituals. A man or woman of this caste goes about from house to house singing songs that are supposed to remove the evil eye. Whether or not they were once independent of begging for their livelihood, they are, clearly a class of privileged beggars now. It is a sin not to give to privileged beggars of this class, just as it is a sin not to give to Brahmins. Large numbers of people who belong to non-begging classes are now being drawn into professional beggary, but their position is different from that of the begging castes. They have no right to demand charity, but have to rouse and appeal to the sentiment of compassion of the rich. Members of the begging castes like the Pulluvans and the Nayadis are not usually referred to as *pichchakkar* (beggars), but by their caste-names only. What is given as charity is known as *pichcha* or *dharmam*. That the latter word, which means 'duty,' came to have the meaning 'alms' may seem curious, but because it is part of one's *dharmam* (sacred duty) to give charity, presumably the part has come to be known by the name of the whole. The word *danam* (gift) which is the Sanskrit equivalent of charity is used only in connexion with gifts to Brahmins.

Method of Begging and Giving Charity.—Special days are fixed for giving charity to the Nayadis—Saturdays and Wednesdays in the Palghat taluk, Fridays in other parts of the country. In addition to these, there are also special days such as the twelfth days of both the waxing and waning phases of the moon, and important festive days such as the *Onam*, *Vishu*, etc. All the members of his begging parish will be personally known to the Nayadi. He stands at a great distance from each house to which he goes and cries out '*Tamprane, Tamprane*' (Oh Lord) in his loud voice till one of the inmates hears him and brings something for him; it may be a couple of handfuls of husked or unhusked rice, or more rarely a pie. When he is given something to eat the food is served into his areca-leaf food receptacle. The powerful voice of the Nayadis has frequently been commented upon. Its training begins in very early years, for even children begin begging and imitate their elders' method of crying for alms. When a man howls loudly, people ask him, "Are you a Nayadi to howl like this?"

Sometimes it is more profitable for the Nayadis to beg on the road-side. As they cannot remain on the road itself, a loin-cloth is spread by the side of the road and when passers-by approach, a vociferous cry of 'Oh lord, give something' rings in their ears and induces them to throw a pie or a quarter of an anna on the beggar's rag. This method of begging is resorted to only in urban areas near busy thoroughfares or market places.

Men of means make it a point to feed the poor and the Nayadis, particularly on birth-days. Charity is supposed to prolong life and make its path smoother for him who gives. People say that the merit of charity is the capital that man invests for his well-being after death. It also adds to the kudos of a person if it is widely known that hundreds of the poor were fed on his birthday or on the occasion of some other domestic ceremony. So when the Nayadis are fed there is this double object present. The Nayadis remember the asterisms under which all the important men and women of their particular parishes were born and have a wonderful memory for them. When a child is born they enquire and make mental notes of its name, the star under which it was born, etc. Then the following year they remember to visit the house and standing at the usual distance cry out, "To-day is the birthday of so-and-so. May the little *tampuran* live long." When a large number of Nayadis are to be fed, word will be sent to the local Nayadi to get his men from the neighbouring villages. After they have all been given food which they eat in the open, they stand up in a circle and raise a cry of 'Ah, Ah' which can be heard far. The leader of the group says, "To-day the *tampuran* has fed so many of us. Let all the villagers know that." and then the cry is repeated in chorus. Nayadis are fed with special attention on the occasion of the feasts on the conclusion of death-rituals. In some parts of the Walluvanad taluk, on these occasions they should be fed before any of the other *Chandala*¹ or lower castes, as they are regarded as the Brahmins among them, taking only their sacredness into consideration and not their rank. In giving charity precedence is usually in the order of caste gradation and on other occasions and in other places no such exception in favour of the Nayadi is made. As, however, a store of food from which a man of a lower caste has been served becomes unfit for consumption by one of a higher caste, in practice, when a Nayadi has to be served first, his share of food is kept aside before anyone else is fed, but is not actually given to him until afterwards.

Death-Gift.—Of greater importance economically to the Nayadis are the gifts that are given them to ward off death. Such gifts are known as *kala-danam*, Kala being the god of death. The hour of death is supposed to be presided over by Gulika, the son of Saturn and the object of the offerings made to the Nayadis is to avoid death by placating Gulika, Saturn, and other demons. It is considered extremely dangerous to have anything to do

¹ Strictly speaking, Chandalas are the offspring of intercaste marriage of the *pratiloma* type, that is, the mother is of a higher caste than the father. None of the lower castes of Malabar are Chandalas according to this definition, though they are usually referred to by that name by orthodox Hindus.

with the offerings to these dangerous demons and the Nayadis are, therefore, doing a very valuable service by receiving them. When a man is dangerously ill, a messenger is sent to the Nayadi's hut to invite him. The gift has to be received in the morning and never in the afternoon. Paddy in an earthenware pot, rice, chillies, sesamum, mustard seeds, charcoal, a cucumber, and a coconut are tied up into a bundle in a black blanket or a new loin-cloth and this bundle together with an umbrella and a walking stick are waved thrice over the sick person and are then handed over to Nayadi and not placed at a distance as in the case of other gifts. It is said in the *Jatinirnayam* that the Nayadi utters a curse over the bundle, "Be dead, be rotten," and that the curse is supposed to have the reverse effect. All my Nayadi informants, however, denied doing anything of the kind. They maintain that the account of the author of the *Jatinirnayam* is a mere fabrication and say that they meditate and invoke the aid of their ancestors and gods to remove the evil influence of Saturn from the dying man. All the offerings are taken directly to the *mannu* and offered to the gods and only after that are taken to the huts. Children, and sometimes women, do not partake of the food materials got in a *Kala-danam* as they are believed to have a deleterious influence on them.

In the Ponnani taluk when a man is very ill, a crude bier is made of bamboo, and the stout stem of a banana tree to represent a dead body is placed on it and taken by two relatives of the sick man to the hut of a Nayadi with a bundle of the various articles that constitute the death-gift and presented to the Nayadis. Sometimes a figure of a man is made in boiled rice with mustard seeds and sesamum to mark the eyes. This figure is waved round the sick man and then presented to a Nayadi. Sometimes, the dying man is asked to look into a dish of oil and see his own shadow in it and then this oil is presented. This presenting of the oil is known as *chayadanam* (gift of the shadow or image). These offerings are clearly symbolic of death, and the belief underlying the rituals is that by mimicking death and thus satisfying the anger of the demons the real catastrophe will be avoided. If the offerings are not taken away from the house, the spirits will still linger there. The umbrella and a stick in a death-gift symbolize the journey that the spirit of the man would take if he died.

It is often said that the Nayadis care very little about the fate of the man on whose behalf they have received the death-gift. This again, however, is not true.

Divination at the Time of the Death-Gift.—The Nayadis have various methods of reading the fate of a patient on whose behalf they have received the death-gift. One method consists in the diviner holding three burning wicks in his left hand and putting out their common flame by stifling it between the fingers of the right hand. If the flame is put out with trouble and burns the fingers, the patient will not recover. In a hopeful case, on the other hand, the flame will allow itself to be handled "as though it were water," to quote an expression used by my informant. A second way of divining is by throwing up three lighted wicks and

noting the direction of the burnt ends when the wicks fall down on the ground. If any of the wicks has its burning end pointing to the south (the cardinal point of the god of Death), the patient will not recover. Sometimes the diviner draws a circle one foot in diameter and drops three or seven wicks into it. It forebodes evil for the patient if any of the wicks is outside the circle. By tasting food the Nayadi diviner is able to find whether a patient will survive or succumb; if hopeful, the food will have its normal taste, etc., otherwise it will "taste like a corpse." In cases where the divination gives a bad prognosis the diviner does not openly convey the information to the relatives of the patient, but veils it in grave warnings.

Comparative Data on Death-Gift.—Brahmins receive gifts from persons of rank just as the Nayadis do from commoners when someone is on the point of death. In the royal family of Travancore, "when death is imminent *kaladanam* or the death-gift is made. A buffalo is brought; it is covered with valuable cloths, the neck and horns decked with jewels, and a little fire in a pot tied under its belly, but without touching it. A Brahmin is called, who receives four *paras* (measures) of sesamum seed and a few rupees, and is then mounted on the buffalo and sent away."¹ In this ceremony of *kaladanam* a parody is made of the passage of a spirit on the vehicle, the buffalo, of the god of death, to the world of the fathers with an ample store of sesamum which is the favourite food of the spirits in Yama's world.

In Cochin State, when death is imminent, two men arm themselves with pestles to which bundles containing various articles used in death-offerings are tied up. A small pit is dug on the southern side of the house of the dying person and a cock is killed and its blood poured there. The two men with the pestles then run southwards without looking back. This ceremony is supposed to ward off death by simulation of it as the people describe the passage of the spirit into the other world to be towards the south.

It is considered extremely derogatory for a Brahmin to receive the death-gift and before receiving it they perform expiatory rites. Cases are also on record where Brahmins have been outcasted for receiving gifts without the proper ceremonies preceding it.

Hunting.

Nayadis as Hunters.—In the *Keralolpatti* (18th century A.D.) hunting is mentioned as the profession allotted by Sankara to the Nayadis. Sankara's role as the creator of the present social order and caste professions of Malabar is, of course, a fabrication, but it embodies a good deal of tradition that is useful to the student of cultural history. The statement in the *Keralolpatti* that the Nayadis lived by the chase may be accepted as a historical truth. But, despite the caste name Nayadi, which means 'hunter,' only a few of the Nayadis living to-day do any hunting at all. Instead, they find occasional employment as beaters in hunting parties that are organized by higher castes. Their skill as beaters and trackers is scarcely to

¹ Mateer, "Native life in Travancore," London, 1883, pages 136-137.

be excelled. They manufacture the best hunter's ropes and their hunting songs are still believed to have the power of inducing sleep in boars and other game. The growth of such a superstitious belief as the last-mentioned strengthens the evidence afforded by the tradition in the *Keralolpatti* regarding the original profession of the Nayadis. The rigidity of the forest laws and the Arms Act and the difficulty of making a living by the chase must have made the Nayadis give up their ancestral profession and become habitual beggars. This unfortunate fall from hunters to beggars was accelerated by other circumstances such as growth of population, mentioned in the section "Nayadi Country and its Cultural History" (pp. 2-5).

Hunters' Gods.—The god of the Nayadis, *Maladaivam* (god of the hills), who is believed to protect them from tigers and other wild animals when they are out hunting, is worshipped at most of their settlements. In a few places Nayadis worship Sasta or Ayyappan (Aiyandar), the guardian deity of the jungle-clad hills protecting Malabar on her eastern borders, and also the patron deity of hunters (plate vi, figure 3—mounted figure on the elephant). He is really a deity of the higher castes, but some of the Nayadis have adopted him. The tiger is also occasionally worshipped and ritual dance in honour of the tiger-god takes place in connexion with this cult (p. 79).

Manner of Trapping and Hunting.—The Nayadis occasionally catch monkeys in ropenets tied to trees by driving the animals into them. Rabbits are caught in similar nets two feet high and about four feet long tied across some narrow passage into which the animals are driven by the small group of hunters. There are now few among the Nayadis who possess any special skill as archers, though it is said that a few decades ago many of them used to shoot pigs effectively with their bows and arrows. Having lost their skill as archers, some of the younger Nayadis are extremely keen on possessing the country-made muzzle-loading gun used by hunters in rural areas:

When the villagers decide to have a boar hunt, Nayadis and others who serve as beaters and gunmen assemble at a central place in the village, when it is time for starting to the jungle. There, the leader of the party announces to which particular part of the jungle they will go. The belief is that if the announcement is made earlier, the beasts will clear away from that part of the jungle. Then the god of the hunters and the spirits of ancestors who were good at hunting are promised offerings to make their venture a success. The hunters arm themselves with muzzle-loading guns and lances, guns having now completely replaced the arrows and darts of olden days. The men with the guns station themselves on trees towards which the animal is likely to come in its attempts to escape from the dogs and the beaters. Such a station is called *kadavu* (passage). The Nayadis and other beaters begin the drive on one side of the jungle usually the upper and the dogs on the other. There is always very wild singing during the beating and other stages of a boar hunt. In a deer hunt there is much less of it.

The name of the animal hunted is not to be mentioned during the chase. If it is, the animal will escape. So the various animals of the jungle are given descriptive names which the hunters understand quite well. When a boar is seen the beater says, "A thorn has pricked me. Get a pair of pincers (to pull it out)." This expression means "I have sighted a boar. Please get the gun." Seeing a fox early in the morning is regarded by all people as very auspicious, but the good effects will be nullified if the name of the animal is uttered. So in mentioning the incident to others the figurative name of the animal is used. A list of the descriptive names used by hunters of Malabar is given below :—

Boar	<i>Vaypitiyan</i> .—He who catches (attacks) by the mouth (tusks).
Rabbit	<i>Olachchechian</i> .—He that has leaf-like ears.
Fox	<i>Attukatiyan</i> .—He that bites the goat.
Deer	<i>Vallappottu</i> .—Buffalo of the jungle.
Porcupine	<i>Kallatakorrnan</i> .—Buck among the stones.
Varanus	<i>Mankuri man</i> .—The deer of the pit in the soil.
Serpent	<i>Uttina vaypitiyan</i> .—He who attacks by blowing with his mouth.
Rat-snake	<i>Eruttani valan</i> .—He who has a tail like a writing style.
Elephant	<i>Kotachchechian</i> .—He who has umbrella-like ears.
Bison	<i>Vallanappottu</i> .—Elephant-buffalo of the woods.
Tiger	<i>Chutan</i> .

Distribution of the Kill.—The distribution of the meat of the game killed is a formal matter and has to be done in the manner traditionally prescribed. In the Walluvanad taluk, the head of the animal is given to the villagers, one of the hind quarters to the Nayadis, the other to the Nayar chief of the locality, one of the sides to the man who shot the animal first, the other to the person who shot it second if a second shot was needed. Some meat is also given to the carpenter and blacksmith of the village. What remains is given to the other people who partook in the hunt.

Logan describes the method of dividing the game and hunting rights in ancient Malabar thus :—

"The village hunt like everything else in the life of a Hindu community was conducted precisely according to ancient corporate customs. The *urpalli* was the place where according to custom game must be broken up. The man even who alone could perform this office had a hereditary right to officiate. He was called the *kaiikkaran* or attendant (perhaps originally an elder of the village). As perquisite he had the other hind quarter of the animal. The hunter who killed the animal had as perquisites the head and one fore-quarter. A share of the flesh was given to each of the hunters engaged in the hunt, and three pieces were distributed among those who came to the *urpalli* to see it cut up. The animal was methodically cut up into eighteen customary pieces. The *urpalli* was a place in the jungle duly consecrated to the hunting deity Ayyan or Ayyappan and it was in front of his

shrine that the formal ceremony took place. The hunting season opens on the 10th or 11th of *Tulam* (October-November) of each year and these days are still considered of importance in places where game is still to be found. The permission of the chieftain to hunt in his territory was not required and it was never sought, and the idea of an exclusive personal right to hunting privileges in certain limits is entirely foreign to the Malayali customary law. Such an idea was only imported into Malabar with English courts and English law and lawyers. There was a fundamental difference in the ideas from which originated the Malayalee law of land tenure and the English law of land. . . .”¹

Hunters' Songs.—The following is a modern song sung by Nayadi beaters, which is believed to hypnotise the boar :—

alupole kayyum kalumeranni amamma ayyayya

With the fore and hind-legs coming down as the roots of the banyan tree.

pontukolupole tandellum vechunne.

With backbone placed like a piece of floating wood.

kutira pole valu minnichchunne.

With the tail flashed like that of a horse.

anapole chevietuttu.

With the ear held sharp like an elephant's.

varakka pole terra vechchu.

With the tusks placed like plantain fruits.

atakkapole kannum turichchu.

With the eyes protruding like arecanuts.

korana pole mukkum vechchu.

With the nose placed like the fruit of the *Korana*.²

ettakotta pole talayum vechchu.

With the head placed like the water-basket of the water-lift.³

katavattannana.

Come to the gap.

tokkvarinnanannuvannane tha tho-o-o-o.

Come near and near, O gunners.

The song is sung in a chorus, the singers being within hearing distance of each other.

¹ W. Logan, "Manual of Malabar," 1906, page 173.

² I have been unable to identify this fruit. It is probably *Negritia pruriens*.

³ The receptacle for water in the Malabar type of the *picota* is a rectangular wooden vessel, narrowing down from the mouth to the bottom, and if the lines of the boar's head were made rectilinear the simile is quite justifiable. The term basket applied to a wooden vessel is suggestive of its origin from a water-tight basket.

Directions to one another from distant members of the party are given in lines of crude verse. For example, when one of the beaters is to be asked to get into the circle, the cry is :

Natulu po, ekku mukku mula kuti elakki telikke Kora-o-o-o.

Get to the middle, beat into every corner and hollow, O Kora.¹

“*Nayattuwidhi*” or the Rules of the Chase.—Hunting was in ancient Malabar one of the most popular of sports, but has now ceased to be so. Before all important national festivals Nayar chieftains used to organize hunts in which they tried to excel one another. It is said that there were magical formulæ capable of summoning the game to the hunter, rites that would ensure success in the chase, and charms that would make the hunters’ weapons unailing, and their persons invulnerable. Magical practices in connexion with hunting are, however, being rapidly forgotten, and unless the traditions are quickly recorded, they will probably be irretrievably lost. A full summary is given below of a rare palm-leaf manuscript in Malayalam in the Madras Oriental MSS. Library entitled *Nayattuwidhi* (Rules of the Chase); the manuscript is unfortunately in a very imperfect condition :

Some *Naga* women were going to *Vaikuntha* (Vishnu’s Heaven) with offerings to Vishnu. On their way they saw four stone animal figures in the valley of Mount Meru. They presented these to Vishnu, who gave them life. One of the figures that got life ran into the jungle, the second into the water, the third to the village, and the fourth fell down. That which ran into the jungle became the wolf, that which jumped into the water became the otter, that which went to the village became the village dog, and that which fell down became the fox. Vishnu presented all these animals to the godling Ayyappan who, therefore, became the god of hunters. This godling dwells in temples (*kavus*) the most important of which is the one at Chamravattam in the Ponnani taluk. And the godling gave these animals to his worshippers (*Chevakar*), and with them hunting became possible.

Next is described how the various hunters and their modes of hunting originated. When Ravana shook Kailasa, Siva and Parvati got annoyed and wanted to send some one to see who was disturbing them. From Siva’s “Glory” there arose a monkey which, however, never returned to him. Siva threw his “Glory” out again, and from it arose a wild man of the jungle. This man dutifully obeyed his creator’s orders and brought him the news that was wanted. The god was well pleased with him and blessed him and assigned to him the happy life of the jungles with complete mastery over the wild beasts. Thus arose the men of the forests, the *Kattalas*.

When Siva was fighting against Arjuna to curb his pride, he was assisted by the hunting peoples. He divided them into eleven *Kutis* (huts) and therefore eleven tribes are found among them to-day.

¹ The name of the individual.

When the hunting party were ready and before the drive was begun the men meditated for a moment and invoked Ayyappan and other gods in order to avert risks from themselves and their friends. The song which initiated the day's proceedings has the following components :—

Ayyayyo, for the invocation of the godling Ayyappan ; *ayyo*, for the spirits of the jungle ; *ento*, again for Ayyappan ; *ento*, for summoning the dogs ; *ento*, addressed to the Nayars (hunters) ; *tiro tiro tiro*, to the beasts of the jungle ; *ariyattet*, to the dogs ; *to vayyo*, again to the beasts ; *ento ayantayatto*, to all ; and *gata etto*, to *Gulikan*.¹

The personnel of the hunting party consisted of men in charge of the dogs, at least four beaters, the archers, and the Nayadis who were called the " friends who stand at hand."

Then began the beating (*tendal*) which was preceded by a special form of cry :—

Etto etto ariyatto ariye ayattayatto.

Vayatto vatoypra.

The actual beating of the jungle was accompanied by the following cry :—

Ullatu ullatu ettopullatu.

Ilakiyal aratti kutti peru.

Ayya tekku tekku etta etta etto etto.

Pattiyattatto ato atato ato

Ayya kukukyi kukukyi.

Ayya tekku kaliyarku patiyo.

Kuliyay vaitto.

Vaypitiyan ayyannattikonde—kollayyo.

Most of the expressions in the above cry are meaningless sounds. The intelligible part of it means : There it is, there it is. If it moves close upon it on the south. You there, block the passage out. Into the mouth of the *Gulikan* let it go². Drive in and kill the lord, pig.

When the prey was moving about the cry was :—

Etto etto ayya tekku kaliya patiyo.

Kuliyay vaitte vaypitiyan ayyannattikonde kollayyo.

This couplet means : " Drive the lord, pig, into the mouth of Death."

When the beast was lanced for the first time the " cry for the blood " was :—

Ayya ni etto etto—Ennunni pattam itteto.

Vaypin muriye chorayum—Kayyalattero otittero.

Vannitiyal muriye otittero—Tirttukollo tirichchukollo.

Vaypitiyan muriyechorayum—Errunni paitale kayyalattero.

¹ Son of Saturn, presiding over destruction.

² The phrase means simply " kill it."

This song is addressed both to the wounded animal and to the leader of the hunt and its purport briefly is as follows :

Oh you my child, have you put on the diadem ?

Have you broken and wounded the boar ?

Have they wounded you and made you bleed ?

Other songs of a similar nature are given that were to be used when the animal received further wounds.

Diet.

The production and distribution of food in the family, the kinship group, and the larger local groups have as great a scientific interest as marriage or religion in any simple society. No sociological study has so far been made of native diet in South India, though such work has been done for Africa by several members of the London School of Anthropology.¹

Sources of Food Material.—The Nayadis produce very little in the way of food stuffs, for they obtain most of them by begging. In their kitchen gardens they cultivate a few of the articles which serve as subsidiary items in their dietary. They do very little fishing as other communities specialise in it, and, moreover, few of them have access to the water where fish is caught. Hunting and snaring in the jungles, and collecting in the rice fields, give them a meagre supply of animal food of which they are very fond. In the course of their begging tours they get cooked food, part of which is eaten on the spot and the rest carried home for the children ; they get as a rule unhusked rice, and occasionally chillies and salt. Part of the rice is bartered for toddy, fish, tobacco, betel leaves and nuts, condiments, coconut oil, kerosene, etc. Very little actual food is purchased, except rarely some sweets, or parched or beaten rice. These things are purchased on special festive occasions at the fairs in connection with the annual celebrations at the temples.

Vegetable Food.—Rice is the staple food of the Nayadis as of other people in South India. The unhusked rice as it comes from the threshing floor is boiled and sun-dried, and then husked. Husking unboiled rice is difficult as the grains are soft and are easily broken into small fragments, whereas boiled and sun-dried grains are harder and can stand pounding better. Sun-dried rice is first beaten in a broad, low mortar(=*Kuntani*) with a hole at the bottom, till most of the husks are removed. Then it is transferred to a smaller, but taller, mortar (*ural*) and the beating with the pestle repeated till the brown aleurone layer is removed and the rice polished. The bran and the husks are removed by sifting in a basketry winnow (*muram*).

The rice is washed further with cold water just before it is to be cooked for eating. The washed rice is put in boiling water for fifteen to thirty minutes till it becomes quite soft.

¹ Raymond Firth, "The Sociological Study of Native Diet", *Africa*, VIII, 4 ; Audrey I. Richards, "Hunger and Work in a Savage Tribe", 1932.

When the rice is consumed as *kanni* or gruel, the water is not strained away. When it is required solid as *choru*, the water is strained away with a basketry strainer¹ or it is simply decanted with the help of a wooden board placed on the mouth of the cooking vessel to prevent the rice from coming out with the water. As the Nayadis, being very poor, cannot afford to eat *choru* more than once a day, they take it only at night, whereas richer people have it twice. The evening meal (*attaram*) is usually eaten between 7 and 9 p.m. In the morning the Nayadis either eat what is left over from the previous night, which is generally rice gruel with very little rice in it, or they prepare fresh rice gruel. Only the children get something cooked for them at midday, the adults having to be contented till the evening with the rice gruel consumed before 9 o'clock in the morning, before going out on their begging tours. To the rice gruel salt is added to improve its taste and sometimes coconut scrapings may also be added.

As subsidiary items of food various vegetables are used. Boiled bananas with a little salt added to them and flavoured with coconut oil are greatly relished with rice gruel. Tapioca (*Manihot utilissima*) is grown in the kitchen garden. The root of the tapioca is skinned, boiled and eaten. Or for use with rice it may be flavoured with coconut oil in which mustard has been fried. Dried chippings of tapioca are powdered and made into porridge. Sweet potato (*Ipomea batatas*) is eaten green or boiled.

The starch from the fish-tail palm (*Caryotaurens*) is obtained by pounding the pith and straining it with water on a piece of cloth tied across the mouth of an earthenware pot. The starch then settles to the bottom and is removed in a semi-solid condition after the water has been slowly decanted away. This dries to a powder, which is then stored. The powder is boiled with water, coconut scrapings and coconut jaggery to make a much relished porridge. The root of *Marunda arundinaceae* is treated in a similar way and very delicious starch obtained. The starch of the umbrella palm (*Corypha umbraculifera*) is also eaten during starvation months. The roots as well as the young leaves of *Colocasia antiquorum* are eaten after removing the irritants in them by thorough boiling. Cucurbitaceous plants are grown by all people and their leaves and fruits form the commonest vegetable dishes that are eaten with rice.

Animal Food.—The Nayadis and other lower castes have a particular partiality for non-vegetarian dishes, fish and meat being regarded as delicacies. Nayadis sometimes buy dried sardines, prawns, etc., which are either merely scorched by placing them on glowing embers or made into curries. The Nayadis invariably keep fowls, but they kill and eat them only on very important occasions, e.g., the new moon day when offerings have to be made to the spirits of the ancestors. The men kill the bird, remove the feathers by plucking, and scorch the down and any small feathers that still remain. The crop is emptied of its contents; the gizzard is cut open and cleaned. The entrails are not eaten. Flesh and fish are

¹ The Malayalam term for this is *Kayil Kotta* or basketry ladle.

cooked alike. To the cut meat or fish a paste of chillies with a trace of turmeric is added, with enough water to make the required quantity of stew ; when it is cooked fully, salt is added, after which it is flavoured with onions fried in coconut oil. Nayadis occasionally get the meat of the wild boar, rabbit, porcupine, jungle fowl, etc., but this happens very rarely. During years gone by, monkeys that were accidentally killed or shot used to be sent to the Nayadis, but now others also have begun to eat the prohibited meat of the monkey with the result that the Nayadis do not get much of it. During the monsoon months pond snails (*Pila globosa*) are plentiful in the fields. They are boiled in water, the operculum removed, and the animal extracted from the shell and cooked in the same way as mutton. The pond snail is regarded as a good remedy for piles, and is therefore, eaten by people of higher castes also, but for medical purposes only. Fresh water mussels and mussels from the brackish water of the backwaters are also eaten. Crabs which are obtained in large numbers in the fields during the rainy season are roasted on embers and the soft parts eaten without further cooking. Occasionally the Nayadis catch mud-tortoises, which they find by poking likely-looking heaps of mud with a sharp stick.

Nayadis have a certain notoriety for eating rats, which is regarded as an extremely dirty habit. They, however, consider the rat delicious. Several South Indian tribes like the Irulas and the Yanadis share the Nayadi's taste for rat.

Nayadis do not eat any carrion and this fact gives them a status above that of the carrion-eating Parayans. They also avoid eating beef which is extremely repugnant to almost all Hindus.

Spices.—The most important spice that the Nayadis use is chillies. To give a sour taste to various relishes tamarind fruit is also added. Coriander, mustard, cumin seed, garlick and onions are other items added to produce flavour.

Drinks.—The Nayadis use the water in which rice has been boiled as a drink. The tea habit is spreading among them very slowly, crude coconut or palmyra sugar (jaggery) being used in the place of refined sugar.

Intoxicants.—The inflorescence of the coconut, fish-tail, and palmyra palms give a juice which on fermentation contains alcohol and is known as toddy (*kallu* in Malayalam) which is a cheap drink, within the means of the Nayadis. They can be found in the evenings going with their women and children to the toddy shops. They have to remain at a distance from the shop and are not allowed to drink from or touch the cups that others use. Instead, the toddy vendor pours the beverage into vessels which they take with them. Nayadis say that they drink toddy because it relieves the muscular weariness of continued wandering in the blazing sun. While among the higher castes drinking toddy is regarded as an anti-social habit and looked upon with contempt, among the Nayadis it is regarded as quite a normal and healthy thing, though excessive indulgence in it is condemned. The word shop

(which when pronounced by uneducated people becomes something like 'Sap'), seems to have been one of the earliest of English words to be adopted into the Malayalam language, judging from its general use, and has come to mean a toddy shop when used by itself.

Betel Chewing.—At least a tenth part of the daily income of a Nayadi is spent on betel leaves, areca nut and tobacco for chewing. First the betel leaves are smeared with a small quantity of slaked lime. Then the kernel of the areca nut is sliced and ground in the mouth, followed by the leaf and last of all the piece of tobacco. The areca is supposed by its users to strengthen the gum of the teeth, the juice of the betel leaf to remove the sliminess of the tongue and the mouth, the tobacco to stimulate and energise the mouth, and the lime which with the other juices forms a red mixture, to beautify the lips and the mouth. A 'white mouth' (= untinted by chewing) is regarded unseemly and unbecoming. Teeth discoloured into a dirty brown by constant chewing of betel and nut are extremely common and give the mouth a dirty appearance.

The sociological aspects of betel chewing are important not only to the Nayadis, but also to the people of South India in general. When a visitor comes, the minimum, but essential hospitality to be shown to him consists in offering chewing materials. In all important ceremonies, betel leaves have to be presented to the visitors. An inferior going to a superior takes with him an offering of betel leaves for the latter. When there is a death feast in the house of a relative, betel leaves have to be taken by the relatives to be given to the master of the house who gives the feast. Betel leaves are the commonest of gifts between relatives. Younger people should not chew the leaves in the presence of elders. Young unmarried women should not offer betel leaves to youths as it is considered an act of familiarity. When any one is tired, betel leaves are chewed as a stimulant. After every meal elderly people make it a point to chew. It is only for chewing that the men and women of a household sit together. The little box or basket containing chewing material becomes for the Nayadis thus the equivalent of a fireplace in an English home.

Consumption of Food.—There is considerable variation according to the season in the quantity of food that each person in a family gets. Immediately after the harvests in *Kanni* (August-September) and *Makaram* (December-January) more doles are obtained by the Nayadis as people have more to give. The month, *Karkatakam* (June-July), when the monsoon is at its worst, is the famine season; then none except the youngest children get enough food to enable them to eat their fill. It is only on some festive days that every one in the house gets adequate meal during this month.

Before eating in the morning all clean their teeth with charcoal, and the tongue by scraping it with the split midriff of the coconut leaf. Hands are washed before every meal. In the daily distribution of food the men and the boys get larger shares of food and are served earlier than the women and girls. When there are guests they are served first and the hosts

eat only afterwards. Women eat in the kitchen separately from the men. The food is brought by the wife or the mother in earthenware dishes and placed on the floor in front of the men who sit on a plank or a mat.

The rice is mixed with the vegetable or fish curry and made into boluses and these boluses are thrown into the mouth. The water in which rice has been boiled is drunk both when the rice is being eaten and at the end of the meal. If there is anything left in the earthen dish, the women eat it. It is also their duty to clean the vessels after the meal. Rice gruel is eaten with a coconut shell ladle or with a leaf spoon. Stale rice gruel which has become sour by fermentation is also drunk in the mornings during famine months.

Outside the regular meal times Nayadis get very little to eat. During the hot months, mangoes, jack-fruits, etc., are available. From January onwards the cucurbitaceous plants that they grow in their kitchen gardens begin to yield fruits some of which are eaten raw.

Children are fed with rice from the fifth week onwards. A paste is made of the boiled rice, and small quantities of it thrust into the baby's mouth with the index finger.

All animal food is avoided during death pollution. Flavouring of food is prohibited during smallpox and cholera epidemics as the smell is supposed to attract the blind crawling demon that causes these diseases.*

Presents of food between neighbours and relatives of a kinship group are common. Meat being a great delicacy is always shared. As has been mentioned above, it is mainly on religious occasions when offerings have to be made to the gods and to the ancestors that the Nayadis have meat food. The food offerings to the gods which one family makes are distributed to the remaining families in the kinship group, because the food is believed to be sanctified and the gods are the common gods of the settlement.

That the Nayadis suffer from perpetual semi-starvation is obvious not only from the meagreness of the list of articles that go to form their dietary, but also from their poor physique and the deficiency diseases, such as the premature wearing away of the teeth, from which they suffer.

The value set on rice is so high that their reverence for it is well expressed in many sayings and ritual attitudes to it. When some one treads on a grain of boiled rice, his action meets with immediate disapproval of those standing near by who say "You are trampling King rice (Anna Rajah) down." Dropping mustard seeds on the floor is supposed to cause quarrels among the members of a family.

Domestic Ceremonies and Customs.

Marriage.—It is the rule for every adult Nayadi to marry and become a householder. Among those known to me, there were no spinsters; only one was a confirmed bachelor, but he was a deaf-mute. Widows usually remarry even if they have several children, though there

* See author's article, "Myth of the origin of smallpox", *Folk-lore*, XLII, 3.

are some that continue to live at the husband's settlement with the children, begging in the husband's parish. In obligatory cross-cousin marriage there is a social mechanism to provide every one, however undesirable, with a partner in life.

Early betrothal is very common, the formality being undergone when the girl is eight or ten years old. If a brother has a little daughter, and his sister a young boy, the sister ties a string of beads round the neck of the young girl saying, "She is for my son." Little Ponni of Kizhoor is only ten years old, but she knows whom she is going to marry. Ponni's brother told me that the cousin to whom she is betrothed gives her presents occasionally, e.g., he made her a couple of nice slings which she sold for an anna. The little girl felt shy when I asked her about her fiance and chided her brother when he let out the information. Intimacy grows up before marriage and leads to pre-puberty and pre-marital intercourse between the prospective bride and bridegroom¹. It is very seldom that an early betrothal which is strengthened by occasional gifts to the girl is revoked by either parties. In one instance, when the betrothed parties were not close relatives, but yet the young man was allowed to have access to the betrothed girl, the promise was revoked by the man's group and as a result of the breach of promise, the two parties came to blows. The girl's mother told me that, in spite of this mishap, she hoped that her daughter would be married by some decent young man.

When betrothal is not effected early, the parents, or in their absence, near relatives on the father's side "go in search of" a bride, which means that they pay formal visits to relatives of theirs who have marriageable daughters. When a girl is selected a ceremony is held known as *achchāra kālyanam*, i.e., the formal settlement of the contract by paying a small sum as "earnest money." At the settlement of the contract, the day of the marriage, the amount of money to be paid as bride-wealth, and the number of guests who would come with the bridegroom to the bride's house are all fixed. If the bride is an own uncle's daughter, the bride-wealth is only nominal. Where the bride is less closely related the amount of bride-wealth is greater. Most people are anxious to pay as high an amount as possible in order to make divorce by repayment of the bride-wealth more difficult for the bride's relatives².

There is little likelihood of any higgling in connection with the fixing of the bride-wealth which is about Rs. 2 to Rs. 4 in most cases. No marriages are celebrated in the months of *Dhanu* (December-January) and *Kumbham* (February-March) which are considered very

¹ The Nayadis have no knowledge of contraception or abortion, but I heard of only one illegitimate birth, and here the offender was not a Nayadi but a Mannadiyar who was forced by the local landlord to pay compensation to the Nayadi girl.

² According to the classification of the Hindus, a marriage wherein the bride's father receives any consideration for his daughter is regarded as characteristic of Asuras. Among the Vedic Aryans the bride brought wealth with her in the form of cows. Brahmins in South India, however, used, until recently, to pay for their brides. I owe this information to Dr N. Venkataramanaya, Reader in Indian History and Archaeology in the Madras University.

inauspicious. Those months immediately following the harvest are the marriage months. Marriages are prohibited on the first day of every month, and during the pollution following either death or birth.

On the evening of the day previous to the marriage, five or six people of the bridegroom's group go to the bride's house. Of these one ought to be the bridegroom's own sister or in her absence some one who is closely related to him as a classificatory sister. They carry with them two pieces of cotton cloth, one as a loin cloth and the other as a body cover for the bride, and also some strings of beads and the cash to pay the bride-wealth. Such people as have ancestral figures of brass (plate ix) carry them also, because they are anxious to have every part of the ceremony gone through with the blessings of their departed relatives. The bride's people also get ready for her some ornaments of brass and of beads and a nice palm-leaf umbrella.

The ceremonies proper take place in the forenoon. The auspicious hour for the ceremony is usually prescribed by the village astrologer. The sister of the bridegroom dresses the bride and ties the strings of beads round her neck, or in some places, instead of the beads, ornaments of brass or silver. No Nayadi marriage is possible without the sister. In the Wailuvanad and the Ponnani taluks the most binding part of the ceremony is the ritual eating together by the bridegroom and the bride with their brothers and sisters¹. Food is served in an earthenware dish or on a banana leaf and the men sit on one side and the women on the other. In the Palghat taluk this ceremony is replaced by *Kainanakkal* or "wetting of the hands" which consists in the father of the bride pouring water into the hands of his daughter which is allowed to flow into the hands of the groom who keeps them just below hers. This is comparable to the *udaka purva kanya danam* (gift of a virgin with water) of the Namputiri Brahmins and is probably a more recent adoption.

"When a donor transfers a property to another and retains no proprietary right" the procedure is known as *nir attiperu* (right obtained by water) and is similar in nature to the 'hand wetting' at the marriage ceremony³.

For the Brahmins the binding part of the ceremony is the 'seven steps together' with 'fire' as the witness.

² In a Namputiri wedding "The bride and her father stand facing the west and the bridegroom facing them. All three stretch out their hands, so that the bride's hand is between those of her father and the bridegroom, which are above and below hers respectively. A Namputiri Otikkon or ritual expert pours water thrice into the father's hand. The latter each time pours into his daughter's hand and then grasping her hand pours into the bridegroom's hand. The dowry is then given to the bride who hands it over to the bridegroom." Thurston "Castes and tribes of Southern India" Vol. V., p. 207. The similarity in rituals is merely superficial, because the economic transactions in Nayadi and Namputiri's marriages are in opposite directions, as Namputiris pay bridegroom-wealth, not bride-wealth.

³ When land is being sold "at the time of executing and delivering the deed, the following persons must be present. A *svajati*, a person of the same caste; *Bandhu*, relative; *Putran*, literally the son, but in Malabar construed to mean the heir, whether a nephew or son; *Narupati*, the Raja; the writer of the deed; *Tatra sambandhi*, a resident round the spot. In practice the attendance of the Raja or the execution of the deed before the Raja is dispensed with. It is only necessary that he should be appraised of the transaction. The mortgagee gives two *fanams* which is placed in a small vessel of water; the mortgagor holding the deed in his hand pours water over it, which the mortgagee receives as it falls, and either swallows it, or puts it upon his head, or upon his feet, or upon the ground, according to the relative castes of the two parties. The deed is then delivered to the mortgagee." Logan, "Malabar" Vol. II, Appendix xiii, p. clxxi. The deed would be engraved on copper.

The close resemblance that a Nayadi marriage in the Palghat taluk bears to a business transaction explains its nature as an essentially social matter without involving anything religious. It merely intensifies by new economic transactions and the creation of fresh relationship ties, the existing kinship bonds between two groups that are already related. The eating together and the "wetting of the hands" are for the validation of a social contract. It may be said that eating together creates religious bonds, but such arguments are far-fetched in the present context. Nayadi marriages are sometimes contracted outside the immediate kinship group but do not then have the same stability that cross-cousin marriages have. Since the marriage tie is not the only link between the husband and wife in an enjoined cross-cousin marriage, any dispute between the husband and wife, or between their respective groups, will be settled promptly, because the father-in-law of the husband is also his mother's brother, or father's sister's husband. When there is only a distant relationship, disputes are difficult to settle and outside agencies such as the landlord or employer have to be appealed to. Resort to the courts to settle disputes is a costly method beyond their means.

Divorce is not so common as to deserve special notice. I came across only one woman who was living away from her husband while he was alive. The husband was an incapable man, and the wife ran away from him with a Cheruman to a village where both of them were unknown and lived as man and wife for a few days till her relatives traced her and brought her back. When the wife was brought back, the husband requested her relatives to send her to him, but they refused to do so. The information given by the Nayadis is that divorce takes place when the husband is a ne'er-do-well or a tyrant, or the wife excessively lazy or quarrelsome. In the event of a divorce, the bride-price has to be returned and accounts of all money transactions settled. The guilty party being responsible for the break up of the marriage has to pay the other some compensation for the marriage expenses that have been wasted. Most divorces take place before children are born to complicate the situation. When there are children they are retained by the father. A divorced woman is allowed to see her children, but she should not look again at her former husband. Children being the only investment and insurance against old age that the Nayadis have, the divorced wife suffers a very serious loss.

In the Walluvanad taluk an elder brother—own or classificatory—is allowed to marry the widow of the younger brother, but a younger brother should not marry his elder brother's widow, because she is to be regarded as having the status of his own mother. This rule does not, however, hold good for the northern parts of Cochin State. Genealogical tables of the Kunnamkulam colony showed that a man there had married his classificatory elder brother's widow paying the bride-wealth over again though it was not necessary to do so. In the Palghat taluk levirate either senior or junior, is unknown¹.

¹ Among the Gonds an elder brother is not allowed to marry his younger brother's widow because the elder brother is held to stand in the position of the father of the family. See Hayavadana Rao, C. Rao Bahadur, "Gonds" *Anthropos* Vol. V.

Polygamy is rare among the Nayadis, but it is not unknown, e.g., Kandan of the Olavakkot colony married two sisters, first the elder and then the younger, when the first was found to be barren. Children by the second wife are usually known as "children of the second house (*kuti*)" which expression reminds one of the primitive custom of each of the co-wives having a separate hut. The co-wives among the Nayadis live together in the same hut.

Panikkar,¹ ascribes a very curious marriage custom to the Nayadis which consists of the girl being shut up for a while in a hut of green boughs and all the young men eligible to marry her standing round the hut, each thrusting a stick into the hut, the one becoming the husband of the girl whose stick she catches. Iyer² ascribes the same custom to the Ulladans quoting *verbatim* the passage from Panikkar. So far as the Nayadis are concerned, such a form of marriage is unknown, nor do the oldest among them remember anything like it prevailing even in bygone days.

Puberty.—Nayadi girls generally attain puberty between the ages twelve and fifteen, the reason ascribed for its delay in some cases to the latter age being the general under-feeding and the poor physique consequent on it. After puberty the girls reach full womanhood very rapidly. Most of the marriages taking place before puberty, girls menstruate for the first time in the husband's house and the ceremonies in connection with it are at the expense of the husband's people. The vernacular expression for the first menstruation is 'letting the age be known.' In some places the girl is secluded in a hut of very small size, but in most others she is kept in the corner of the living hut screened off by a piece of cloth or green leaves³.

This seclusion lasts for a fortnight. Men should not eat anything cooked in the hut in which the girl is kept. She is bathed on the 4th, 7th and 9th days by the sisters of her husband in a tank or puddle of water. On the ninth day when they go to the tank, a man, usually a cross cousin, carries a *bali* (a triangular frame of the leaf sheaths of the banana tree with short pieces of the tender white leaves of the coconut tree stuck into it with lighted wicks in it) in front of the procession. The girl has to immerse herself in the water seven times. At the seventh time the *bali* is floated over her head. This is supposed to remove all evil spirits that are likely to have entered her when she was in a delicate condition readily susceptible to their attacks. On her return the girl puts on a new cloth, an umbrella is held over her, and

¹ "Malabar and its Folk", p. 143.

² "Cochin Tribes and Castes", Vol. I, pp. 61-62.

³ The Ulladans have a permanent menstrual hut (*tindaripura*) in which women are temporarily housed not only during the first menstruation, but at all subsequent monthly periods, and no adult male is to approach it under normal circumstances. I witnessed a young Ulladan husband who was very angry with his wife, whom he suspected of adultery, throwing stones at her from a distance as, at the time of his coming home, she was in the menstrual hut near which he could not go.

the men cry out *arappue* aloud, this being a cry of joy or victory according to circumstances. All the relatives are then fed sumptuously. The whole ceremony is known as *tirantu kuli* or *tirantu kalyanam* (bathing after the first menstruation or the auspicious ceremony in connection with the first menstruation).

Pregnancy and Child-Birth.—When it is known that the wife is pregnant, the husband lets his hair grow long and stops shaving his beard. It is said that in the sixth month of pregnancy Nayadi women are given the flesh of the monkey to make the delivery easy. In the eighth month she is given a mixture containing various herbs, the ceremony being known as “eating the sour things.” After this ceremony a woman who is pregnant for the first time is generally taken to her paternal home as it is believed that her mother will take better care of her than any one else.

For delivery, as for menstruation, a special hut is built some distance from the house and the woman is attended by her mother or some other female relative. It is necessary that the hut for confinement must be far from the *mannu*.

Wherever there are Mohammedans, experienced Mohammedan women assist at the delivery, but in other cases, very little outside help is available. The after-birth is buried under a stone slab on which the mother sits and bathes; the belief is that if it be allowed to get dry, harm would befall the baby. In cases of difficult delivery holy ashes (of burnt cowdung) are thrown on the woman by an elderly man after due meditation upon the ancestors with the ashes in his hands. If lactation is poor, the father of the child cuts the stem of some plant with latex, usually a *Euphorbia*, and makes the milky juice flow—evidently an example of sympathetic magic.

Barrenness and abortion are believed to be caused by evil spirits eating the foetus that is being formed. In some women such spirits take a permanent abode causing them to grow weak and emaciated.

Thurston records that the Nayadis practise *couvade*: “When she (the wife) is in labour, her husband shampoos his own abdomen, while praying to the gods for her safe delivery.” My Nayadi informants did not know of any custom among them that could be compared to *couvade*, but told me that others had also asked them about this curious custom.

Birth pollution lasts for twenty-eight days during which any one who touches the woman becomes impure and has to take a purificatory bath. On all the twenty-eight days she is bathed in hot water, after having her body smeared over with turmeric paste. She is fed well and

¹ *Couvade* is common among the Koravans and the custom has been recorded by Al Beruni in the following words:—

“When a child is born, people show particular attention to the man, not to the woman.” Sachan, Edward, “Al Beruni's India”, Vol. I., p. 181.

given several herbal preparations to make her strong. She is specially susceptible to possession by spirits and, therefore, carries with her always the knife with which the navel cord was cut, when she goes out from the house to answer the calls of nature, the iron of the knife having the power to keep evil spirits away. Certain evil spirits are believed to have no regard for her impure condition, while the generality of them avoid her. Those spirits are attracted by the human blood that they can get from haemorrhage during and after delivery. The woman is given nothing that is supposed to cool her, e.g., bananas, toddy, etc., as it is supposed that they will retard the healing process, while hot substances such as mustard, asafoetida, pepper, etc., are supposed to do her good. The cooked leaves of *Moringa pterygosperma*, a common vegetable food, are believed to help lactation.

Naming and Rice-Giving.—On the twenty-eighth day, the mother bathes and ceases to be polluting. The child is given a morsel of the staple food, rice, by its father's sister, or its father's mother and the name to be given to it is muttered in its ear, or in some places, it is spoken aloud.*

Nayadi personal names are, some of them, the names of Hindu gods, and the rest naturalistic descriptive names that are characteristic of the hill-tribes. The usual male names are Chattan, Chemban, Kandan, Krishnan, Kunnan, Kuppandi, Nagan, Nilakandhan, Palani, Raman, Rekkan, Sankaran, Teyyan, etc., and female names Ayichi, Ayya, Chakki, Chinna, Kali, Kuppa, Kurumba, Nagu, Nangayya, Nangeli, Nili, Ponni, Sita, etc. Of these Krishnan, Raman, Sankaran are well-known Hindu names, Chattan is a degenerate form of Sasta, a name of the South Indian village god Ayyanar. Chemban is a really primitive name meaning, 'he of the brown colour', Kandan is the name of the god of the Palni Hills, Palniandi, a form of Subrahmanya. The name Palni is that of the sacred hill on which that god resides. Nagan refers to serpents that are worshipped. Kunnan means "small one," Kuppandi means the "mendicant of the rubbish heap." Among the female names, Kali is that of the well-known Hindu goddess to whom the names Nili (the blue one) and Kurumba are also applied. Sita is the name of heroine of the epic, Ramayana. Ponni means "the golden one"; Nagu means the "Serpent". Nangeli and Nanga are both characteristic Namputiri Brahmin names, the meanings of which are not quite clear. Ayichi and Ayya are old Malayalam words which means 'mother.' Kuppa means rubbish. Chakki is in all probability a degenerate form of Sakti, the female aspect of the Divine. The Nayadis have such a short list of personal names that even within a small group names are very much repeated, and persons are referred to, for example, as Big Raman, Small Raman, etc.

Some low castes of Malabar like the Cherumans and Kanakkans who are very near the Nayadis in social gradation name their children 'Nayadi' on the supposition that this will

* Among the Namputiris, the naming is on the tenth day and the rice-giving in the sixth month.

give the child a longer lease of life, because the mean and lowly associations of the name would make it beneath the dignity of the god of death to take any notice of its bearer.

It is an inviolable rule that a child should be named after some close relative either dead or living. This practice does not involve any belief in reincarnation, because the idea of reincarnation is unknown to the Nayadis and to other low castes. It is done only to commemorate the dead, or honour the living.

Hair-Cutting and Ear-Boring.—The hair of the new-born baby can be cut on any day after the twenty-fifth day from its birth. The mother's brother cuts the hair and the child's father has to present him with four annas, if it is a girl, and four or five times as much if it is a boy. Sometimes the uncle is also given a cotton loin-cloth. Till the age of ten, girls used to let the hair grow only in the patch at the crown of the head (see page 87); but nowadays they begin to grow it all over the head from the age of three or four.

The maternal uncle bores the earlobes. Formerly it is used to be done late, but now for girls it is done between the fifth and the seventh years, and for boys when they are a few months old. The mother's brother gives the child a piece of cotton cloth and gets from the child's parents a present of a fanam (four annas and eight pies). Close relatives are given a feast by the parents of the child on the days of hair-cutting and ear-boring. On those days food offerings are made to the gods and ancestors of the settlement. But nowadays there is a growing tendency among the Nayadis and among the higher castes also to treat these rites in a casual manner and to omit feastings and formalities.

Death Rites.—Because of the difference in the degrees of contact with other castes, the mortuary practices of the Nayadis differ in each of the three cultural areas, Palghat, Walluvanad and Ponnani with parts of Cochin. In the description of death customs that follow, the points of difference are noted. When death approaches all the relatives pour water, or water in which rice has been boiled, into the mouth of the dying person. It is a privilege and a duty to do this last service to a dying relative. Referring to a child the fond parent is usually heard to say, "I have to take care of it, because it will give me water, when I am dying." No regret is more keenly felt than that for one's inability to pour a few drops of water into a dying parent's mouth. When the eye rolls backwards, life is believed to leave the body either through the nose or the eye. Evil-doers die with gaping mouth. What goes off from the body is known as *uyir* (energy), or *jivan* (life). It is also believed that soon after death the blood in the body dries up.

From the moment of death all the agnates of the deceased person are under *pula* (pollution) and are called *pulakkar* (those under pollution). They are interdicted for fifteen days from going on begging excursions, from shaving, from smearing oil on their bodies or heads, from chewing betel leaves and from partaking of animal food. For a period of twelve months after the death, the wife or the mother or both of the dead man must cover their

heads when they go out. For the fifteen days of the death pollution they must remain indoors, a custom which is known as 'sitting in the shadow.' Those under death pollution are prohibited from approaching the *mannu*. It is thus clear that the mourners are regarded as unclean and on a par with women in menses in so far as ceremonial purity is concerned, but the dietetic regulations for them are like those for sacred fasts. Durkheim is of opinion that the interdictions observed by the Australians during mourning are a proof of the sacred condition of the mourners. Among the Nayadis, however, we find that the mourners become more 'profane' in spite of the series of food tabus. The interdictions on the Nayadi mourners are in the nature of canalised modes of giving expression to the grief by mortification of the flesh and are no indication of the sacredness of the mourners.

Immediately after death the corpse is covered with a piece of cotton cloth. All the relatives are sent for, particularly the brothers and sisters, for no dead-body should be burnt or buried before the brothers and sisters have seen it. The women wail all the time, the characteristic way of expressing grief at this stage being by beating the breasts with both the palms simultaneously. The relatives by marriage who come in one after the other bring with them tobacco and betel-leaves. When the relatives have assembled, the body is decked with all the finery the dead person possessed. In some localities in the Ponnani and Cochin areas, bathing the dead is insisted on. The sons throw grains of rice and leaves of *tulasi* on the dead body, which is then swathed in a new piece of cloth. *Tulasi* (*Ocimum Sanctum*) is a well-known plant very sacred to the Hindus.

In the coastal villages of the Ponnani taluk dead bodies are buried quite near the hut where the deceased lived. Only in and around the Palghat taluk are there special burial grounds, common to all members of a caste, usually situated on the bank of a river. According to the *Keralolpatti*¹ each caste had a common burial ground till the days of the great Hindu teacher Sankara who ordained that each man should bury his dead near his own house. In these places, therefore, the body is carried by the sons on a frame-work of bamboo that looks like a crude ladder. Only the male relatives follow the corpse to the burial ground, women remaining in the hut. The chief mourner is the eldest son or in the case of a person without children, the eldest of the younger brothers. In the interment of the body, the Nayadis take particular care to dig the grave very deep for two reasons (1) the bones of Nayadis are much sought after for magical purposes, as it is a common belief that, if a piece of a Nayadi bone is buried in a particular place, evil spirits that share the abhorrence of the upper castes for contact with the Nayadis will be kept away, and (2) there is always the risk of the grave being disturbed by burrowing animals, particularly foxes. Nayadis living near rural towns like Olavakkot make it a point to bury their dead only at night and keep the place of burial a close secret. The body is carried seven times round the grave in an anti-clockwise direction and

¹ See page 7.

lowered into the grave from the eastern side. The mat on which the deceased used to sleep, his walking stick and the little basket in which he kept betel leaves are thrown into the grave. The body is buried face upwards with its head to the south, and its legs to the north, the only exception to this rule being that in some parts of the Palghat taluk the corpse is buried with the head to the north.¹ When the grave is half-filled, thorny shrubs are put in to prevent jackals from getting at the corpse. When the whole grave is filled, earth is heaped up along its whole length forming a mound, on which three boulders are placed, one over the head, one over the chest, and one over the feet. The Nayadis themselves are not quite clear as to the object of placing the boulders on the grave. It has been suggested that they are to prevent the spirit from escaping, but this explanation is based on very superficial knowledge of the facts connected with death rituals among the Nayadis. It is not one of the objects of the mourners to imprison the spirits in the graves, nor do they believe that the spirits inhabit the grave. As the Nayadis themselves suggested to me, the boulders may be simply for the purpose of strengthening the interment.

Before returning home from the burial ground, the rite of *kallum tolum vekkal* (placing the stone and the twig of leaves) is performed. On the boundary lines of the burial ground, north and south of the grave, the chief mourner plants a leafy twig and places on it a small boulder, declaring as he does so, "We shall not cross this boundary line until there is another death." Any Nayadi who has to pass by the burial ground takes care that he does not tread in the interdicted area.

Placing the leafy twig on an object was in ancient Malabar a legal method of imposing a *tabu* on an object and preventing any one from touching or removing it. In the jungles, even now, one occasionally comes across people placing a leafy twig on faggots or pieces of wood they have collected to prevent any one from taking them away. Goods used to be attached by courts of the native rulers by placing a leafy twig on them. On analogy with these local practices, the placing of the boulder and the twig of leaves on the boundary line after the burial may be regarded as tantamount to dividing the region of the dead from that of the living. Reference to similar practices are found in the Vedas.

For ten or fifteen days² from the day of death, every morning *bali* (sacrificial food) is offered to the departed. All the agnates bathe, and after tucking their wet loin-cloth between their legs, sit on the left heel with the left knee resting on the ground and the right knee raised up. Then, led by the chief mourner, each places a few grains of moistened rice (*bali*) on the tip piece of a banana leaf. When all have done this, the chief mourner moistens and

¹ The Savaras bury their dead with the head to the north in memory of their tribal origin in the north. There is no similar tradition among the Nayadis and it is not possible to understand the real significance of this aberrant practice of certain Palghat Nayadis.

² Ten days in the Walluvanad taluk and fifteen days in other places. Ten is also the number of days of pollution for Brahmans.

then claps his hands. This clapping is supposed to invite crows which, accustomed by habit, are easily brought in large numbers to the spot where the grains of rice are placed and eat off the leaves, quite readily. --Crows refusing to take the offering means that one or other of the mourners has not observed the tabus properly. Only *Corvus macrorhynchus*, big crows without the pale collar, are known as *bali-kakka* (*kakka* is the Malayalam word for crow), though the common crows, *C. splendens*, are also fed with the *bali* offerings.

Reference was made in the section on 'Social Organisation' to the piece of the shroud called *sesham* or remnant which is cut off after the body has been swathed. The chief mourner keeps for himself the largest part of this remnant giving smaller strips of it as *seshams* to the rest of the mourners. Each is expected to have his *sesham* always on his head except when sleeping, till the fifteenth day, when on the completion of the mourning all the *seshams* are buried in the mud of the tank in which the mourners bathe.

On the third day there is an elaborate offering of toddy to the deceased. The chief mourner sits facing the west and the rest of the mourners facing him. A piece of banana leaf is slightly warmed to make it soft and small cups are made from it. Two such cups are placed one on either side of the chief mourner, toddy is poured into them, and seven grains of rice and seven pebbles are put into the toddy in each. A kind of brush is made by tying together flower heads of *Leucas aspera* and each of the cups is provided with one brush. The chief mourner stands up and sprinkles the toddy from the cup on his left with the leucas brush seven times on his toes and the eighth time on his breast; then with the brush he sprinkles toddy on the mourners sitting opposite to him. When this has been done, they proceed to partake of the toddy kept in earthenware pots for their consumption. In the villages near Kunnamkulam this ceremonial drinking of toddy is done immediately after the burial. A portion of the toddy is kept apart in a small pot for offering to the deceased. When the mourners have finished drinking, the chief mourner pours a few drops of the toddy from the small pot on his right big toe, accompanying the act by muttering, "As (I) have been giving to (my) father up to this day, so here, (I) give", and then he touches his forehead by way of salutation. The formula gives some clue to the meaning of the rite. The drops of toddy poured on the toe are for the spirit of the deceased and the drops poured on the mourners are to make the latter participate ritually in the consumption of the liquor. Similar participation in the offerings both by the celebrant of a rite and the deity or the spirit is a characteristic feature of numerous ceremonies of other castes also.

In the Palghat taluk the offering of the toddy is made in a somewhat different manner. Before the mourners partake of the repast of toddy, small squares of palmyra leaf are cut, the chief mourner bends over the pot of toddy, and taking a few drops of the drink on a square piece of leaf, throws it backwards over his head. This is repeated thrice, but no formula is uttered; the chief mourner pours out the drink first for himself and then the rest follow his example.

On the seventh day special *bali* is offered, consisting of rice, mustard, green gram cakes, milk, and crude sugar (jaggery), which are then sprinkled with water by the mourners and carried in a vessel to a pool of water in which it is immersed. People living near the sea throw the *bali* in the sea.

On the night preceding the last day of death pollution, the mourners have to starve. Next the *Inangan* prepares the materials for the final day's offerings, which consist of boluses of cooked rice, rings cut from coconut kernel, *pappadam* (fried gram cakes), and bananas placed on a bell-metal dish. Lighted wicks are placed on the dish with the food materials. The chief mourner (or the daughter in the case of woman) carries the offerings on his head to a pool of water, wades in as far as he can go and immerses the vessel. The *Inangan* cleans the vessels and brings them back. All the mourners are then shaved¹ except the chief mourner who continues to go unshaved for one full year (plate v, fig. 4). One of the affines acts as barber on this occasion, though at other times, members of one household are each the other's barbers. After the shaving, the *Inangan* removes the death pollution of the mourners by performing *tali*, i.e., sprinkling on the mourners water to which cowdung and the barks of several varieties of the fig tree (*Ficus religiosa*, *F. bengalensis*, etc.), have been added. The same solution is sprinkled on the hut and also the place where the sacred stones are kept. In some villages a mixture of cowdung, gingelly oil, and water is used for the *tali*. The mourners break the tabu against smearing their bodies with oil and bathe to remove the pollution. Cowdung in water is a common purifier, and the oil added to it serves to break the taboos when the mixture is sprinkled on the person under pollution.

Elderly people in the Walluvanad taluk are usually cremated, not buried. In one instance an old man died in the month of *Mithunam* (July-August), when the monsoon is at its height and dry fire-wood extremely scarce, so his relatives used doors and windows for making the funeral pyre. Such is the importance attached to cremation. The corpse for cremation is prepared in the same way as for burial and placed head to the south on the pyre which is usually made of the wood of the mango tree. Coconut shells are placed below the faggots as they catch fire more readily. The son then sets fire to the pyre on the left side at the leg end and the maternal uncle or his sons at the head end. The person who sets fire at the head end receives a present of about four annas from the chief mourner either on the day of the cremation or on the sixteenth day after death, and he, in his turn, gives the chief mourner two or three pieces of new cloth. After the fire has consumed the body, the agnates and *Inangans* go anti-clockwise round the pyre seven times. On the seventh day the charred bones are gathered. Sixteen teeth or if they are not all found, pebbles to make up the number, the various joints and all the cranial bones are collected, tied in a piece of white cloth and placed in an earthenware vessel. The *Inangan* gathers the charred bones from the funeral

¹ Among the Brahmmins, shaving takes place at the commencement of the mourning.

pyre, the chief mourner picking up only one of the teeth and the cranial bones. When the *Inangan* has finished collecting the bones, he explains to the chief mourner the parts of the body to which each fragment belongs. The pot of bones is suspended from a *Ficus* or some other milky tree¹ outside the compound fence of the huts of the mourners, and on the fourteenth, fifteenth, and sixteenth days, water is sprinkled on it to 'quench its thirst.' On the sixteenth day some copper coins are put into the pot of bones and all the relatives, men, women and children, throw rice into it. On the seventeenth day the ceremony of 'going to the river' is held. The chief mourner takes the pot and gives it to the *Inangan*, who carries it on his head on a pad made of cotton cloth. The pot is buried on the bank of a stream, its mouth flush with the surface of the soil. *Bali* is performed and after bathing the mourners return home.

On page 77 of the Madras Museum Bulletin, Volume IV (1901), Thurston writes: "Sometimes, during the seventh month after death, the grave is dug up and the bones are carefully collected, and spread out on a layer of sticks arranged on four stones placed at the corners of a pit." These charred bones were collected in a pot and tied on a neighbouring tree and then buried by the side of a stream. Such double burial is now very rare. But in the case of women who die at their husbands' village, the entire bones, or if that is difficult, at least a few fragments of the bones, have to be sent to her paternal village so that she may have her resting place along with her paternal ancestors. Her grave is, therefore, opened at the end of the first year and the bones are gathered and tied in a cloth. If a Nayadi man happens to die far away from his house and is buried there, his relatives dig up the bones and take them to his birth-place. Some twenty years ago, a Nayadi girl near Pattambi was drowned and her body could not be found. Her relatives felt very keenly their inability to have even a piece of the girl's bones.

The belief of the Nayadis in the survival of the dead is very strong. Rekkan, the seventy-year old Nayadi of the Olavakkot colony, gave his views on this important question in very categorical terms when I asked him for an expression of opinion. "My dead father," he said, "is with me in my home, otherwise what is the meaning of the offerings that we make to our *karanavans* (elders)? They help me when I am in trouble, shield me from danger, and come to me when I invoke them." The Nayadis talk to their ancestors as if they were alive, and standing before the stones representing them they weep and pray and beat their breasts. Though there is, of course, some fear of the spirits latent in the heart of the Nayadis on account of the difference in their respective modes of existence, the relationship between the dead and the living among them is nevertheless tender and affectionate.

¹ Compare the Munda practice of suspending from a tree the charred bones together with a grass effigy of the dead in a piece of cloth. (Roy, "The Mundas", Ranchi, 1912, p. 462.)

The spirit is supposed to wander till it is "housed" (*Kuti vekkuka*). This housing ceremony is performed either on the fifteenth day after the death or on the completion of the first year. All the sons and daughters go to a pool of water wherein they have already placed a piece of stone about one or two feet long, immerse themselves in the water and while they are still wet, take the piece of stone to the *mannu* where stones representing ancestors and gods are kept (plates vi, vii, viii, figs. 2-5; 1; 2, 3). In the arrangement of the stones the usual mundane considerations of sex and rank prevail, stones representing women being placed behind those of men, and children close to and in front of their parents. A large *mannu* will contain as many as sixty or seventy stones. The gods are represented usually by bigger stones; sometimes they may be smaller, but then they have a prominent place, either in the centre or at the beginning of a series. When a local group of Nayadis grows large and is composed of separate branches still continuing to live in the same locality, the sociological subdivisions are reflected in the arrangement of the stones in the *mannu* which is likewise divided up into sections, so that the immediate ancestors of the different social sub-groups are segregated and each group makes its separate offerings. When a new stone is planted, quantities of rice, coconuts, betel leaves and arecanuts are placed in front of it; all the relatives pour coconut milk on the stone and then the chief mourner pours on it the blood from the neck of a cock as a sacrificial offering to the spirit now given a place by the side of the gods and ancestral spirits. Sometimes a wooden figure roughly carved to look like a human being is used instead of a crude stone (plate vi, fig. 2, 3). In some parts of Cochin State, Nayadis in addition make metal figures of the deceased as shown in the illustrations in plate ix, figs. 1-4. Fig. 1 is an armlet with human figures on it. One of the figures is that of a man with a gun in his hand. Such armlets are worn on important occasions by the men. Fig. 4 is a *tali*, an ornament worn by women, with a figure in relief on it with its hands in the *anjali* pose (salutation with the palms joined and placed on the chest). Such ornaments are worn by women on special occasions, but are usually kept reverently in a safe corner of the hut. Figures 2 and 3 are in the Berlin Museum for *Volkerkunde* for which they were collected by Jagor¹ in about 1890. He got them from the neighbourhood of Calicut, an area where now there are no Nayadis to be found, and described them as images of gods. It seems to me more likely that they are of the same nature as the figures on the armlets.

Celebration of "the twelfth month", i.e., the anniversary of a man's death, is done in an elaborate way. In Kizhoor, where I witnessed it, the ceremony was as follows:—

The relatives of the dead man assembled the night before the anniversary day, each bringing his or her contribution to the expenses either as cash or as rice and other necessaries. Towards midnight a branch about 10 ft. long of *palakappayyani* (*Oroxylum Indicum*),²

¹ *Zeitschrift für Ethnologie*, 1894, p. 82.

² Any other tree with plenty of latex can be used instead.

was brought from the jungle by the *Inangans* (the sisters' children) and its bark was completely removed. The *Inangans* carried the branch (which is subsequently called *niraltandu* or the 'shadow pole') preceded by groups of special singers who danced and sang to the accompaniment of drums. Some of the songs had direct reference to the rituals of the ceremony. One of them is translated below :—

- Line. 1 *Taninnam taninnam tanninnane*
 „ 2 Come up the shadow that lies low down
 „ 3 It is the shadow that lies low down
 „ 4 *Tanne tano tanippa taita.*
 „ 5 Come forward the shadow of the elder of Nediyruppu
 „ 6 If there is the "shadow and water" of the *Samutiri*, let it come down.
 „ 7 Even if there is error or fault, the shadow come forward.
 „ 8 (My) Grandfather learnt the learning
 „ 9 After the grandfather, my father learnt this
 „ 10 Let the blessing of the elders come forward
 „ 11 Let the blessing of the brother come forward
 „ 12 Five *tammutta* shadows, hear
 „ 13 *Samutiri's* shadows, hear
 „ 14 Of the Kolapulli village, the Nayadi youth am (I)
 „ 15 I am guarding the *pandal* of the royal house of Kannappataril.

The song is not a coherent whole with a central theme. It is addressed to the "shadows" (spirits of ancestors who are known by the same word as for shadow) that are lying on the earth dissatisfied. The first and the fourth lines are meaningless words that indicate the tune of the song. Nediyruppu in line 5 is the name of a royal house of the Malabar country. The Nayadis probably love to compare themselves during the collective effervescence of festive occasions to the royal families known to them. In line 15 the Kannapataril *illam* is referred to as the royal house of Kannapataril. "Shadow and water" of line 6 is a literal translation of the expression *Nirum niralum*, but the meaning is "spirit." The "error or fault" in line 7 refers to errors of omission and commission in the ritual which make the spirit remain attached to the earth. Lines 8 to 11 have reference to the leading singer of the dancers who explains how he got his proficiency from his father and grandfather, after which he invokes his teachers' blessings. The word *tammutta* in line 12 means the mother's family group. Line 14 again refers to how the singer is keeping up the prestige of the family of the mourners by his singing. There is a good deal of rivalry in singing and, therefore, good singers are always in demand.

The "shadow pole" was then planted upright in the shed. All the people assembled threw up handfuls of rice exclaiming, "Let the shadows that lie low come up. If there is anything wanting for them, let them come up." One of the mourners then got possessed by

the ancestral spirit and expressed his satisfaction with the ritual honour paid to him. The rite of *niralu kettal*, or tying the shadow, followed next. The oldest of the agnates of the deceased person tied parched rice, unboiled rice, beaten rice and paddy in the four corners of a new piece of cloth, which bundle was then tied at the top of the "shadow pole."

Then the eldest of the 'uncle' group got up the pole and untied the bundle. The *Samutiri* (Zamorin), who in Kizhoor belongs to the Kurrikkatan *illam*, said while he was getting up :

"*Mekkoyma mettala vettikko*"

"Overlord, upper end you cut."

On his coming down with the bundle he was presented with five new loin-cloths by the mourners. The rice, etc., in the bundle was taken by the man who climbed the pole to his hut and offered to his gods.

The next part of the ceremony was the "uprooting of the tree" by the *Samutiri*. One of his men said, "Now let the *Samutiri* come and dig up the tree." The *Samutiri* went round the "shadow pole" thrice, pulled it out and placed it down with its top to the east and bottom to the west. Two umbrellas were placed at the top end and the *Samutiri* handed these umbrellas to the chief mourner who had been, for the past twelve months, observing all the tabus of death pollution, growing his beard and hair (plate v, fig. 4) cooking his own food and offering *bali* daily. Accompanied by the mourners the *Samutiri* carried the pole to a tank of water where it was buried in the mud. In the water the mourners went thrice round the "shadow pole" singing the song translated below :—

Let us go to bathe in the weedy tank.

In the weedy tank we bathed.

The "shadow pole" lies low.

Let it come up, the "shadow pole".

This ends the solemn part of the ceremony. Then followed some step dances accompanied by various more or less lively songs in which singers compete with one another. Among these the following traditional song must however be included :—

There was the coconut seedling with one leaf.

There was the coconut seedling with two leaves.

(the same line is repeated but with the number of leaves progressively increased in every succeeding line up to seven.)

The seventh was a rotten one.

The eight was an inflorescence and on it came a tender coconut.

And it became a full-grown nut.

And a one-tusked elephant came to husk the nut.

When cut into two the kernel shone like the rising lord.¹
 And when scraped it filled a sieve.
 And the second half filled another.
 Then the coconut scrapings were all put in one (sieve).
 Then Chi Raman Kunnan ² came,
 Came and upset it.
 Don't you see his utter stupidity ?

Returning home after the bath, the *Samutiri* threw rice on the mourners who stood in a row opposite him, saying as he did so "If the 'shadow' has (the) *Samutiri*, let (it) rise up", by which he told the spirits that it was the *Samutiri* that invoked them to rise up and that they should obey his orders. Then the *Inangan* shaved the head and face of the chief mourner. After the ceremonials of the day the widow of the deceased man was allowed to wear her bead necklaces, which had been removed on the day of the husband's death. On the conclusion of the ceremony, the *Samutiri* was presented with three *naris* (measures) of rice and was given all the toddy that remained after the offerings to the ancestors at the *mannu*. The singers were presented with pieces of cotton cloth, the manner of giving consisting in the donor throwing them round the neck of the recipients.

An all-souls day which resembles the "shadow pole" ceremony very closely is celebrated in the month of *Vrischikam* (October-November) during years of trouble and pestilence. According to the Nayadis the object of the "shadow pole" ceremony is to placate dissatisfied spirits by raising them from their low position of attachment to the earth. In the songs of invocation they are asked to rise up. The parched rice and the tree with milky juice are both attractive to the spirits and their rising up is assisted by the throwing up of rice. When the shaman with the spirits of the manes on him declares that they are pleased the pole is uprooted by the *Samutiri*, a tribal chief with a very grand title appropriated from the most powerful landowner in Malabar.

Among the Ulladans there are rites in connexion with the spirits of the dead that bear close resemblance in ideology to that of the "shadow pole" ceremony. The spirit of the dead man is entrusted to the chief who carries it with a few grains of rice from the burial place and goes to a temple. The grains of rice are thrown up into the foliage of the sacred fig tree there. The chief then solemnly asks the sons of the deceased to look after their father as though he were still living. The ceremony of throwing grains of rice up into the tree is in all probability a process of raising up the "low-lying shadows" to a sacred status.

¹The moon or the sun.

² Probably refers to Sri Rama as a babe (*kunnan*). The story of Rama and Sita is the subject of many songs composed by the illiterate Cherumans of Malabar.

Religion and Magic.

"*Gods and Ancestors.*"—There is no confusion in the mind of the Nayadis as to the distinction between their gods and ancestors, and if they were told by a theoretical anthropologist, that the former were derived and evolved from the latter, they will not agree with that opinion. The *mannu* to the Nayadi is "the place where gods and elders are kept." Ancestral spirits are linguistically only 'elders who are dead and gone'. Their ritual attitude towards gods and ancestors is however, very little differentiated, in spite of the linguistic and ideological distinction made. The rites connected with the installation of the 'elders' and the periodical offerings to them are also used for the gods in all their essentials. Pieces of granite or, in more advanced areas, wooden or metal figures, serve to represent them materially, but the gods have larger stones and occupy a more prominent place in the *mannu*. The same ritual food is offered to the gods and to the 'elders', and both give their 'manifestations' through shamans in the same traditional ways, their personalities being distinguishable not through external paraphernalia, but through the words spoken and the attitude between the profane worshippers and the two classes of sacred beings. The ancestors, though sacred, are intermediate between the gods and living men. Gods are universally worshipped and are common to all, while the 'elders' who were members of a particular kinship group only, are not paid any special regard by outsiders, except that in a very few instances the spirit of a particularly brilliant hunter or magician is worshipped by a larger group than his own kin. The origin of a god is a mystery, but that of an ancestor is not. An ancestor remains permanently attached to his group, but a god's attachment has to be sustained by sacrifices. Gods are more powerful both for evil and for good than the ancestral spirits who are, on the whole, beneficent as a rule and bring only minor ills as reminders of neglected sacrificial offerings. A person is under no special obligation to worship a god unless such worship has been a family tradition, or unless he chooses to do so for his own private ends, but 'looking after' his deceased relatives is a duty that no one may shirk. Ambitious people add to the gods that they worship at their *mannu*, but obviously, the number of ancestors cannot be added to in a like manner.

"*Kalam.*"—The elaborate ceremonies in connexion with the annual *kalam* in honour of the gods and ancestors of the Nayadis at the colony at Kunnamkulam were witnessed by me in the month of *Kumbham* (February-March) in 1930. The word *kalam* by which the whole series of ceremonies is known, denotes only the designs in flour made in front of the stone representations of the sacred beings and is, in fact, a minor part of the function. Another expression less commonly used and being rapidly given up means "seeing the gods". The *mannu* at Kunnamkulam (plate viii, fig. 3) is under a cashew-nut tree (*Anacardium occidentale*) in front of one of the huts. There are half a dozen rude triangular pieces of granite representing gods and ancestors; a long-handled ceremonial sickle designated *val* (sword) with white daubs on the handle is placed against the trunk of the

tree ; all the brass armlets with the figures of ancestors on them (plate ix, fig. 1) are also placed near the sickle. Late at night before the ceremonies began, the small enclosure was swept and smeared with cow dung and decorated by some linear designs drawn with rice flour. Whitish strips of coconut leaf from a young and unopened frond were suspended here and there for ornament.

Before proceeding to the description of the rites, it is necessary that the nature of the gods worshipped in this colony should be briefly described. Maladaivam, the principal god of the Nayadis elsewhere (a god not worshipped by many others), is worshipped here, but his importance is eclipsed by that of three deities of more general popularity, especially Kali, the fearful goddess, the most powerful, and at the same time the most popular of all sacred beings known to the people of Malabar. Her headquarters is at Cranganore in the Cochin State. She is the goddess of good fortune, of small-pox and other pestilences. Popularly she is known as the *amma* (mother) of Cranganore.

Second to Kali in importance is Chattan, known also as Kutti Chattan (young Chattan) or Ulladan Chattan. Though the word Chattan is a corrupt form of Sasta, a synonym for the village god Aiyanar, he seems to bear no relation to that god. He is a very impish deity who pesters people by his pranks when he is displeased, but bestows prosperity on those that pleases him. It seems possible that he may be a deified ancestor.

There is in addition to Kali and Chattan a third sacred being worshipped at the colony under the name Muttappan (Grandfather). Muttappan, as the meaning of the word suggests is an ancestor, but the link between him and the present generation is mythical. The Nayadis at Kunnamkulam do not have in their *mannu* stone representations of every departed relative, but only of those whose spirits proved troublesome.

The old man of the colony was too weak to play his part as the priest-shaman in the day's function, so his son deputised for him. He began by offering cooked food, placing it on banana leaves in front of the stones. The shaman has an assistant who is called *maniyakkaran* (= the manager of a temple or priest's assistant) who next handed him the sickle and fastened round his (the shaman's) waist a string bearing suspended from it the half a dozen armlets with the ancestral figures thereon (plate ix, fig. 1). The shaman held the sickle between his two hands and stood in front of the stone in the *anjali* pose (i.e., with the palms together in worship) with his eyes closed, his feet together, and his legs steady. The audience sat in two rows which sang songs alternately. The purport of all the songs was to invite the ancestors to partake of the offerings placed for them at the *mannu*. One of the songs is translated below :—

Line 1 Oh you, oh you, Grandfather ;¹

„ 2 *Tittittara teittara*

¹ Possibly 'Have Compassion, Oh grandfather.'

- Line 3 *Tana tana tani tinam kelu.*
 „ 4 What fun, what nice way !
Tittittara teittara (etc.)
 „ 5 Oh, little sons, play in a circle, youths.
 „ 6 The sacred 'sword' has been kept bent ;
 „ 7 Rice has been kept fried ;
 „ 8 Arrack is kept in an earthenware cup ;
 „ 9 Take and eat the powdered stuff.
 „ 10 Black arrack has been placed for the old man.
 „ 11 Have you seen the old Guru ?
 „ 12 There is a cock that crows clearly.
 „ 13 In which grove (temple) have they begun firing the mortars ?
 „ 14 From Calicut we hear it.
 „ 15 In which grove do we hear the shaman shout ?
 „ 16 From Calicut we hear him.
 „ 17 It is *asvati*, it is *bharani*, in *Kumbham*.
 „ 18 To-day is the day of the grandfather.
 „ 19 Cough and laugh and come, oh, old man.

The second and third lines are refrains that are repeated after every few lines. In line 5 the leader of the group of singers addresses his companions. Line 6 refers to the placing of the sickle near the stones. Lines 7—10 narrate the items of the food offering. The old Guru or teacher in line 11 is the 'grandfather' who was presumably well-versed in magical lore. The cock referred to in line 12, is the one whose blood has been sprinkled on the stones. The reference to its crowing clearly is to indicate that it is full-grown. During the celebrations of the annual festivities at the bigger shrines gunpowder is fired from a mortar. Calicut referred to in lines 14 and 16 is the headquarters town of the Malabar district and was the capital of the ancient Hindu ruler, the Zamorin. *Asvati* and *Bharani* in line 17 are auspicious asterisms in February-March on which gorgeous feasts are celebrated at most of the Kali-temples in Malabar. In line 19 the 'grandfather' is invited to come coughing, as the author of the song conceives of him as a decrepit old man, which is a good poetic hit.

The vigour with which the songs were sung and the cymbals beaten gradually increased and when the noise reached its climax, the shaman began to tremble, limbs first, and then the whole body ; the hands were then thrown out, the sickle held aloft, and he began to jump up and down shouting ha ! ha ! All the audience then stood up and the whole atmosphere became electrified. The shaman accompanied his ' ha ! ha ! ' by broad smiles. He stopped jumping for sometime and then walked to and fro shaking his sickle, and calling out to the goddess Kali and telling the audience, " My children, you know the prowess of my Mother." As the shaman went on in this manner, his assistant, the *maniyakkaran*

also became possessed and acted in the same way following him up and down. An elderly member of the audience asked the latter if the 'grandfather' was not satisfied with the offerings and if he had accepted everything. Now the cock, an important item of the offerings, was omitted as the celebrants were very poor. The shaman's assistant asked, therefore, "Where is the *changanadu*?" The word, 'Changanadu,' I was told, is the Nayadi shamanistic term for a cock. The audience promised that it would be given the very next month. Through the assistant the celebrants asked the 'grandfather' to protect their children from all diseases and accidents. Immediately afterwards the assistant subsided and sank into the arms of the men who came to his help.

The shaman then began beating his back with the flat of the sickle blade and his chest with the butt. I was told that more experienced shamans inflicted wounds on the head as a proof of their supernormal state, to heal which turmeric powder would be put in. It is said that the shaman feels no pain if he is really possessed. After a short period of self-torture by the shaman, all the Nayadis present were counted, a few grains of rice were given to each, and while all the people and the shaman shouted "ha! ha!", grains of rice were thrown in all directions over them by the latter, the assistant shouting at the same time that every one of them will be well guarded and their number will not decrease. Then the shaman showed signs of relaxing, the assistant took the sickle away and held him in his arms, while the exhausted shaman gasped and sank to the ground supported by others of the group of celebrants.

Scarcely had the shaman finished his manifestation of the Muttappan (grandfather) when another young man was suddenly found rolling on the ground. I was told that Chattan, the impish spirit, was on his body. The youth's mother wept at the sight of her son rolling and threatening the Nayadis there by saying "I will wrench the throat of one of you here." He was given five burning wicks with the flame put out which he swallowed. He was told that proper rituals would be performed on a near date. The essential rites in honour of Chattan consist in the shaman walking through the burning embers of a fire made of the wood of jack (*Artocarpus integrifolia*), mango, and *ayini* (*Artocarpus hirsuta*) trees. It is of interest to note in this connexion that fire-walking is rare in Malabar except in the northern-most taluks, and its survival in a few Nayadi villages unknown to other castes seems to indicate that fire-walking was once more widely distributed there, though it has now disappeared except in secluded social islands remote from newer influences.

My Nayadi informants were not clear on the relationship between the spirits that came upon the shaman and on his assistant. The Muttappan is easily identified by the direct references to him in the songs and from his using the term grandchildren when addressing the group of celebrants. Other deities address their audience only as children. Regarding the spirit on the assistant some Nayadis said that it was a greedy ancestor.

In North Malabar where Muttappan worship is strongest, there is always a companion to the chief spirit and the two share the offerings. Among the Nayadis the cult is found only in a degenerate form, but even among them, the Muttappan does not ask for offerings, but leaves it to be done by his assistant. Analogy with the practice in North Malabar suggests that a subordinate spirit possesses the assistant. In that case his relieving the Muttappan of the unpleasant duty of reminding his worshippers of their omissions would be very natural in view of the local habit of rich landlords employing subordinates for similar purposes.

The little that remains of the cult of Muttappan will disappear from the colony as soon as the few old men who are attached to it die. A new shrine on the Hindu model with a Hindu god in it has been made ; animal sacrifice, the use of toddy and arrack, and the shaman dance have all been mildly interdicted ; and the avidity with which these higher Hindu notions are accepted and assimilated is a clear indication of the psychological gravitation of the Nayadi mind not only in matters religious, but also social, artistic, and even gastric.

The manner of offering sacrifice, etc., to ancestors in most parts of the Walluvanad taluk differs in many details from that observed at Kunnankulam. The rites which I witnessed at Kizhoor in the Walluvanad taluk on the 13th of March 1931 may be regarded as typical of the area. Here the *mannu* was under a teak tree, where, in addition to the usual pieces of granite there were wooden figures of ancestors, similar to those at Pattambi (plate vi, fig. 3) and bronze figures of a boar and a goat. The last two were substitutes for a sacrifice of the real animals in fulfilment of vows which could be carried out as intended. The last day of the month *Makaram* (January-February) is considered to be an auspicious day for making the offerings. There was another reason that necessitated their selecting that particular day, because from the first of the next month, *Kumbham*, the monthly series of shadow plays (*kuttu*) would begin at the local Kali temple during the course of which no minor gods and other sacred beings may be honoured in any special way, as that would be regarded as derogatory to the goddess.

All the materials necessary for the offering were collected by three o'clock in the afternoon. About a rupee worth of toddy was purchased. The cock for the sacrifice could at any time be taken from among the poultry which Nayadis habitually keep. Banana leaves on which to serve the offerings, coconut oil and wicks of rolled cotton rag for lamps, and rice, chillies, coriander and coconuts for the preparation of the offering were all assembled together. The proceedings began with the oldest of the Nayadis there (Sankaran) cutting the neck of the cock and pouring the blood directly on all the stones and figures under the tree. Earthenware vessels for cooking were placed on crude ovens near the teak tree and men began cooking the cock and also rice. Women are not allowed to come anywhere near the *mannu* during the ceremony, though they can watch the proceedings from a distance. Men cook only on ceremonial occasions like this and during big feasts.

While culinary activities were going on one side, Sankaran's uncle, Kunjan, a very old and feeble man came near the teak tree with sandal paste daubed on his fore-head, chest and arms, stood in the same posture as the shaman at Kunnamkulam and began trembling in a very feeble manner. He had no sickle nor assistant nor songs. After working himself up to a degree of tremulousness, the old man went round the *mannu* thrice, then coming to the starting point, shouted "Hey" three times in succession and subsided. Very little notice was taken of the performance.

Each of the family groups cooked its offerings separately. Only the right leg of the cock was cut off and offered raw by being placed in front of the stones. The rest of its flesh was cooked by Sankaran's group. Old Sankaran now sat facing the west in front of the stones with the pot of toddy near him. One of the younger Nayadis poured out a few ounces of the beverage into a coconut shell cup. The old man looked at it, meditated over it and drained it off in a single mouthful. Sankaran is a teetotaller among a people who regard drinking as quite the proper thing for mankind, but the force of religious custom is so strong that on rare occasions of this kind he breaks his own self-imposed tabu. Then he gave similar cupfuls of toddy to every male present there, touching the liquid before it was given, after which wicks were lighted in front of the stones in small iron saucers of coconut oil. Then a leaf-plate was placed by each of the four families present behind the lamps with all their tips towards the east, though on non-ritual occasions the rule is that the tip of the leaf should point to the eater's left. Rice and cock curry were then served on each of the plates. Sankaran was observed to touch each of the plates one after the other. After allowing the food to remain for some time, the leaf-plates were removed, and all present, including the women, partook of it. After the eating was over, the area round the tree was cleared of the cooking utensils and the boulders that served as ovens. Led by Sankaran everyone went counter-clockwise thrice round the *mannu*. When, in the course of the circumambulation, he reached the east and west points, each participant assumed the *anjali* pose. On completing the third round the shaman stopped, began to shiver and stroke his hair and gradually to work himself into a frenzy. He held his palms up and kept on continuously shaking them, and jumping up and down with as much vigour as his feeble frame permitted. He asked for a sickle, but none was available. The Nayar landlord under whom the Nayadis at Kizhoor worked promised that he would get one made for the next occasion. He required it for the torture which the shaman at Kunnamkulam was seen to subject himself to. Saying that he expected everything to be well done at the celebrations in the month of *Karkatakam* (July-August) he quickly subsided.

The many aspects of shamanistic practices found in Malabar are so complex that they cannot be dealt with here. Much of what passes under that name is mere pretence and acting. But in some cases an amount of dissociation is attained and the person gains a certain degree of anæsthesia. I came across a Parayan shaman in Pazhayannore village of Cochin State who

on the slightest excitement such as was occasioned, for instance, by his meeting a stranger like myself, began to act as though he were in the initial stages of a shamanistic performance. The actions and mode of speech used are socially conditioned under the influence of tradition. The genuineness of a shamanistic proclivity in any individual is easily recognised, but though a spurious shaman may be greatly doubted, he will not readily be condemned, as people always give him the benefit of any doubt.

Nayadi Pantheon.—The following is a list of the sacred beings worshipped at the Pudiyangam settlement. They are typical of the Palghat taluk. These with the gods already described complete the Nayadi pantheon :

(1) *Kalladi Muttan.*—The deified ancestral spirit of the Kalladis, a low caste of professional shamans. This spirit is conjured in all kinds of sorcery, especially to cause inflammations of the extremities. Offerings of toddy, rice and the blood of cocks are given in the month of *Dhanu* (December-January) and *Tulam* (October-November), generally, on a Sunday morning. It is only after making offerings to Kalladi Muttan that ones own ancestral spirits should be attended to.

(2) *Saniyan.*—According to the Nayadis this god is supposed to bring ill-luck and is, therefore, worshipped to ward off calamities. Saniyan is the Saturn of the Hindus.

(3) *Velancheri.*—A form of Kali, the goddess of small-pox. According to the legends of Malabar, Kali was installed on the sea-board of the country as its guardian on the west.

(4) *Gurikkanmar.*—Teachers, especially of magic, are honoured after their death by being worshipped in the *mannu*.

(5) *Karanavanmar.*—‘Elders’ or the spirits of the deceased, sometimes referred to as *Muttanmar* (old people).

The oldest of the ancestors that they remember is named and spoken of as the Muttappan or the Muttan proper. In the Palghat taluk he is an intermediary between the gods and his living descendants, and has the important function of intimating to the latter when the gods are angry. When offerings are made to him he informs his men through his shaman whether any of the gods is particularly angry. “Just as you expect to be served your food at regular hours, so the gods wait for their dues and get angry when they are disappointed”; in these words Kandan of Olavakkot, my chief informant at that place, summarised the Nayadis, attitude to their gods. The Muttappan is said to be able to enjoy the “vapour” of his offerings only after the gods have had their fill of the “vapour” of theirs. The Muttappan is given offerings only at dead of night and women are not allowed to come near the spot where the rite takes place. The food offered to him is cooked with the very bitter seeds of *Strychnos nux vomica* in a new earthenware vessel. A cock is killed and the blood dropped on the piece of stone that represents him, and the cooked meat with rice and distilled country spirit are placed in front of the stone (plate viii, fig. 2).

At the Nayadi settlement in the village of Mannalur, there is no Saniyan worshipped, but they have an additional goddess, *Kanni* (= virgin) who is the same as *Kannaki*, the goddess of the immigrant Tamil castes of the neighbourhood, whom the Nayadis have adopted for worship. A preparation consisting of rice and coconut scrapings is the usual offering for the goddess *Kanni*.

The most powerful of all the gods is *Maladaivam* (= the god of the hills) who excites considerable awe in the minds of the worshippers. It is he who protects them from wild animals when they go to the jungles to hunt or to collect herbs and barks. In extremely unbearable situations the Nayadis appeal to him to punish those that do them harm and they believe that he invariably listens to their prayers. Other castes also believe that this god of the Nayadis is relentless in his vengeance and consequently have a great fear of harming them.

Uchchimahakali (plate vi, figure 1), the demon of cholera, is worshipped by Nayadis of the Pallatheri near Palghat. There was an epidemic of cholera which carried off large numbers of the Nayadis there. The survivors were, therefore, anxious to placate the goddess responsible for the disease. Possible sites were thought of for installing her and, to determine which of them would be most pleasing to her, red and white flowers were tied in small packets each representing a site and a child was asked to pick up one of them at random. The site represented by the packet which the child picked up was considered to be the proper one and there a cutting of *Plumeria acutifolia* was planted and in front of it a small mound of earth was made. A small piece of granite was, after proper cleaning, placed on the mound to represent the goddess. In front of it a flat piece of stone was placed on which to pour blood-offerings.

The serpent or Naga is very rarely worshipped by Nayadis. In the *mannu* at the Nayadi settlement in Naduvattam village near Pattambi (plate vi, figs. 4, 5) there is a small image of a Naga (see at the extreme right of fig. 5). At the village of Karakkad, serpent figures are made of flour and worshipped in imitation of the practice of the Chettis in the neighbouring market town.

Pulidaivam (tiger or leopard god)¹ is also worshipped in some villages. He is otherwise called *Puli-Bhairavan*. In the Hindu pantheon Bhairava is a terrible form of Siva accompanied by a dog and worshipped in Sakti puja. When an offering of food is made to the tiger god, a group of men with white spots painted all over their bodies dance round the *mannu* in a circle.

Carved wooden figures used by some Nayadis instead of crude pieces of stone to represent the gods and the spirits of the deceased have already been referred to. At Kuzhal-mannam (plate vi, fig. 2) the *mannu* contains two small figures of ancestors which, though

¹ The Ulladans also venerate the tiger.

very crude, are an advance on the shapeless stones near them and are the result of innovations recently introduced. At Naduvattam there were about a dozen wooden figures that were half eaten by white ants. Seven of them are shown in plate vi, fig. 3. The figure on the back of the elephant is probably that of Aiyanar, though this deity is not usually worshipped by the Nayadis. The rest probably represent ancestral spirits.

The place selected for the *mannu* is always ordinarily under a tree (plate vii) which becomes sacred so that to cut it is a sacrilege. Though the trees seldom belong to the Nayadis, the owners respect their feelings and do not cut them.

At the Olavakkot and Kunnamkulam colonies, the Government authorities have built small shrines for housing the stones of the *mannu* (plate viii, figs 2 and 3). In fig. 3 the usual stones, a walking stick for Muttappan, a bottle which contains liquor offered to the gods and ancestors, and a feather of the cock that was sacrificed can be seen. These shrines, therefore, retain all the characters of a *mannu* except for the tree, but are covered to protect them from sun and rain.

As Nayadis cannot participate in any of the usual Hindu festivals at the temples, they celebrate them on a small scale by feasting on the days when their fellow villagers have their gala time. They have the same festivals as other Malayalis without knowing much about the significance of any of them.*

Beliefs.—The Nayadis' belief in any high gods is very vague. When in trouble or in a philosophic mood they think of the creator who sees everything and is ever watchful, whom they call *Daivam* or *Patachcha Tampuran*, names which are used both in exclamations and imprecations and also occasionally in invocations. The sun is very often identified with the Almighty and in the mornings when they get up, old Nayadis salute the sun with joined palms. But neither the sun nor *Patachcha Tampuran* plays any important role in the practical life of the people. They do not share the Hindu concepts of rebirth, hell, heaven, and the Hindu theory of Karma. For his evil actions no man is directly visited by any supernatural sanctions, but the offended or aggrieved person wreaks vengeance by sorcery or by invoking ancestors and gods to punish the enemy. The curse of a person who has a righteous grievance against another brings suffering to the latter in the form of disease, losses, and domestic troubles. It is not necessary that the curse should be verbal; the deep sense sorrow of an injured person has its harmful effect on the party responsible for the injury. Punishment for evil and reward for good are not postponed to a post-mortem existence in hell or heaven. The human soul is conceived as something ethereal and capable of wandering from the body during life, the evidence for this being drawn mainly from dreams. In explaining to me some incest dreams an old Nayadi told me that evil

* The feasts of Malabar are well described by Gopal Panikkar in his excellent little book "Malabar and its Folk", Madras, 1903.

spirits actually carry the souls away and then force them to incestuous unions and that the intercourse really takes place after which the souls return to their bodies. Most of the dreams that I collected were wish-fulfilment dreams. At death the soul escapes through the eyes or nose or mouth and is never reborn. The Nayadis believe in the survival of personality. When the spirit of a man appears again through the shaman his behaviour patterns during his mundane existence are repeated by the shaman and serve to identify the spirit. The spirit of a clever hunter or magician is invoked for success in their respective crafts.

Magic.—Like other low caste people, the Nayadis are credited by higher castes with the knowledge of powerful black magic. Actually the Nayadis' magical lore is meagre and much less than they are reported to have. The spirits and gods that are made use of in magic by the lower castes are believed to be very powerful, and therefore, higher castes occasionally requisition their services, thereby giving some of these low castes certain influence over the higher castes, owing to their supposed efficiency in creating enchantments and bringing misfortune.

Kunjan of Kizhoor, who had a good reputation as a magician was seventy years old when I met him, but in spite of his age, he was quite vigorous and energetic. But before he would acknowledge to me that he knew anything of magic, I had to curry favour with him for several days. His teacher was a Malayan (a member of a hill-tribe). According to Kunjan, the names of herbs used in death and love magic have to be kept very close secrets, and the teacher makes the pupil take a solemn oath that he would not reveal them. The teacher also tells him that the efficacy of the herbs is conditional to his keeping the promise. Under the guidance of the teacher, the student of magic begins with the daily worship of *Maladaivam*, *Karinkutti*, or *Kali* who are the sacred beings usually invoked to make effective the will of the magician. The tutelary deity of a magician is known as his *murti*. The *murti* has to be satisfied by devotions and offerings, and it is said that he would appear in person to the devotee, when he is satisfied with the latter. Afterwards the teacher instructs the disciple in rituals and spells (*mantras*) and the use of herbs.

The first part of a magical ritual to exorcise an evil spirit consists of an offering to *Ganapati*, the remover of obstacles in the Hindu pantheon, who is invoked to obviate errors in the rituals to follow.

The invocation to Ganapati.

Itichchavilu nanum ganapatikku vechchirikke
Potichcha poti nanum ganapatikku
Puttan kurrikkallum ganapatippatu
Ellam ganapatikkalle vechchirikke
Kirakku patinnarum netunilattilalle kalarippatu
Kalarippatilalle karmannalum vechchirippu.

The above verse means—"I have placed beaten rice for Ganapati. I have placed powdered flour for Ganapati. For Ganapati a new pot full of toddy. Have not all these been placed for Ganapati? The *kalari** extends east and west. The ritual offerings are placed in the *kalari*."

Then magical figures are drawn with rice flour on the floor, and the person supposed to be possessed by the evil spirit is seated in front of the magician with his face to the east. The magician then invokes his deity by repeating mentally the following verse :—

Isvara enre devate Karinkutti,
Devata murti enre Kuttichchattanmare ;
Isvara enre Maladeivame.
Ettinum pattinum pinakkanum ?
Tullattone tullikkanum
Tachchemichche oru pitikonte.

The first three lines of the above invocation contain mere repetitions of the names of the gods and spirits. The meaning of the fourth line is not clear. The last two lines mean :—"To make him dance that will not dance, and to do so by beating and compelling him, holding him in a single grasp (that is without leaving him after once he is caught)." The sorcerer hereby refers to his intention to compel the evil spirit that has possessed his patient to appear and reveal itself by dancing in the usual shamanistic fashion.

Then the magician addresses the patient, as he described it a woman, in the following manner :—

Kanantan penkitave
Evidunnanu devate
Pala kantu pal marattum
Pate chottil eno ?

Meaning—"O, girl of the forest, where is the spirit from? Is it by seeing the *Pala* † (alstonia) or under any other milky tree?"

The deity of the magician is again invoked to come to his assistance :—

Nanoru vilichcha vilippurattu kanatte karinkutti
Ni nallavannam nokki va va karinkutti.
Atattone atikkanum
Tachchalum pichchalum nan vilichhotattu varanam
Nan vilichcha vilippatattettanam.

* *Kalari* usually means the fencing ground. Here it may mean the place where the ceremonies are conducted.

† Evil spirits are believed to haunt such trees as are full of latex.

Meaning of the verse—"Let me see you come immediately on my calling you, oh, Karinkutti. See everywhere and then come to me, oh, Karinkutti. To make him dance who will not dance, you must come whenever I call, even if I ill-treat you and abuse you." That the tutelary deity becomes a servant of the magician is the idea underlying this invocation.

The spirit that is supposed to possess the patient is then addressed :—

*Ellumutta kori kukumpole kuki nilameranni va
Kunnattirikumarayalite tayyu ilakumpole ilaki varatte.*

Meaning—"Crow like a full-grown cock and come down on the earth. Tremble like the leaf of the Pipal tree that grows on a hill top and be excited." These last lines are recited in a loud tone and are suggestions to the patient. When spirits are excited the medium through whom they appear shouts and crows and trembles vigorously. Hence the comparison of the medium to the trembling leaf of the sacred fig tree is very apt. By this time all the lamps will be burning bright, the magician will be staring wildly at the patient and the possessed person begins to shake and make the characteristic sounds. Then the spirit is asked, "What do you want, do you want a full-grown cock? Do you want blood?" Sometimes the patient replies to these queries or the magician will supply an interpretation of the groans. Whatever is asked must be given. Then follows the exorcism of the spirit, which is accompanied by the following verse :—

*Isvara enre Maladaivame,
Ettara gulikan erarassani,
Kantu petichcha gulikan
Enre Elancheri, enre karanavanmare,
Urinnu kalayunnen.*

The verse means—"God, my *Maladaivam*, eight and a half Gulikan, seven and a half Saturn. The Gulikan whom (the patient) saw and feared, oh, my *Velancheri*, oh, my elders, I exorcise." Saturn and *Gulikan* are both supposed to cause sickness and misfortune; the numerals before their names refer to the astrological periods during which they do most harm to people under their influence. The exorcism or *Urinnu kalayal* consists first in the magician rotating his forearm vertically over the face and head of the patient, with some grains of rice in his fist, the motion of the fist indicating that something is abstracted from the patient. After this, the rice from which the spirit is supposed to have come is put in a new earthenware pot and its mouth is closed by tying a piece of cloth across it. Finally it is buried under a milky tree such as *alstonia*.

When elaborate exorcism is beyond a person's means, less costly forms of it are resorted to. One way is to wave a few pice over the patient and then offer the coins to a shrine. Or a cock may be thus waved and, after the spirit has been invoked, sacrificed at the *mannu* or offered at a temple.

The Nayadis are rarely requisitioned by the higher castes for exorcising spirits, because they have specialists among themselves who are supposed to be more expert in the art. The Brahmins are the best magicians for white magic. The lower castes are believed to be more skilled in black magic, the Parayans being the most skilled of them. Nayadis specialize only in the removal of evil eye and in *mattal* (magical interdiction) for which the higher castes employ them.

Evil Eye and Evil Tongue.—In cases of children's illness due to the evil-eye (*Karinkannu* or *chiru*) of women who have lost their children, the Nayadi is invited to receive a gift consisting of rice, sesamum, and a new loin-cloth. A male member of the household comes near the Nayadi and touching his hands the bundle of gifts to him. With the bundle before him the Nayadi prays to his gods and his ancestors saying aloud, "From this day onwards the troubles should disappear." He is given a present of about two annas and dismissed with the promise that he would be given something more on the child's recovering. Words spoken in appreciation of something by an evil-minded person produce deleterious effects on the subject of his remark. The evil effect produced by the tongue is known as *naveru* (the throwing of the evil tongue). Persons affected by *naveru* also seek the Nayadis' help.

Mattal (Magical Interdiction) ¹.—Magical interdiction is resorted to for protecting gardens, etc., from the attacks of pests, and from thieves in particular. Any person who enters a garden or place so interdicted suffers seriously. The rite consists in a Nayadi driving nails into the boundary lines at chosen points, after which he meditates on his ancestors and gods, seated with his head bowed over a pot of toddy some of which he finally sprinkles of the fencing, etc. ² The effect of the rite on the intending thief is that when he tries to get into the garden at one place he will be made to think that an entrance could be more easily effected at another place and in this way become confused. If he succeeds in stealing something he will not live long enough to enjoy the stolen goods. The Nayadis believe that it is not the spell or the rite that protects the garden, but the god, *Maladaivam*, does it. In some instances of *mattal* of gardens I was informed that the Nayadi magician makes a human figure of clay on the boundary line and utters spells over it, but of this I received no confirmation from Nayadi informants.

How dangerous an avocation magic is and also how the Nayadis are employed to perform magical rites are told in the following story narrated to me by Chattan of Karakkad. Chattan's father, Sankaran, was asked by a Nayar farmer to look after his fruit gardens and protect them from thieves. The old Nayadi prayed to the *Maladaivam* with the usual offerings of fried rice (*malar*), rice bran (*tavidu*) and toddy. After the offerings were made,

¹ Gundert's Malayalam dictionary gives the verbal form of *Mattal* the meaning 'to bewitch' or 'to secure by sorcery.'

² Other castes have more elaborate ritual for *Mattal*.

he told the landlord that from that day onwards he would be responsible for even the smallest leaf in the gardens. When it was known that old Sankaran was looking after them the thieves avoided them and the garden produce were quite safe. When, however, he went on the appointed day to claim his reward, the Nayar landlord dismissed him with some evasive replies. Returning sorely disappointed, the old man went to the *mannu* where he wept and prayed to *Maladaivam*. The next day a bullock belonging to the Nayar fell ill and it was thought that it would die soon. The village astrologer was immediately consulted and the Nayar was told that a magician of a low caste had sent his powerful *Maladaivam* to harm him. Sankaran was sent for and he was threatened that if the bullock died as a result of his sorcery he would be made to eat its carcass. Sankaran went back to his *mannu* and again prayed fervently to *Maladaivam* to desist from molesting the Nayar. The god listened to his prayers and the afflicted animal recovered. The Nayar offered some presents to the old Nayadi and requested him to continue to look after the garden, but he refused saying, "The slave does not want to eat any more the carcass of the bullock. I did not mean any harm to the cattle or to the lord (the Nayar), I was heart-broken when you did not remunerate me, but I did not know that *Maladaivam* would take such serious action. The god is not to be played with or made light of." Since it is extremely dangerous to be known as a sorcerer, magicians usually pretend ignorance of magic when they are interrogated on the subject by members of the higher castes.

Personal Decoration.

Dress.—It is impossible to distinguish the Nayadis from other low caste people who inhabit their neighbourhood. They are generally poor in build, sun-burnt, and have a jaded look. When on their begging tours, they put on a cap made of the leaf-sheath of the areca palm (plate v, fig. 2) for protection from the rain and sun, or carry a palm-leaf umbrella with a long handle (plate v, fig. 1). A rope bag for ropes, slings, soap-barks, etc., for sale, and rags for wrapping up rice and other things received as charity is carried slung on the shoulder. A mud pot for receiving food may, if small, be carried in the bag, otherwise in the hand. A staff to lean on while waiting for alms is an essential part of their begging equipment (plate v, figs. 1 and 2). The Nayadis and their staffs are so inseparable that legends have grown up in explanation of the habit (see p. 14, *Legends of Origin*). When the Nayadi stands at ease he does so on one leg throwing part of his weight on the staff. Younger Nayadis are ashamed of putting on the palm-leaf cap and use turbans instead (plate v, figs. 1, 5), but a turban has this inconvenience that as often as a person of the upper caste approaches, it has to be removed as a mark of respect. The palm-leaf cap need not, on the other hand, be removed on such occasions. Women also used to put on the leaf cap, but they have given up the practice completely and go bare-headed. Men's dress consists of a perineal band tightly covering the genitals, which is folded over the waist-string from outside inwards both in front and behind, the end being long enough to hang

loose behind but not in front. A child's first dress consists of a waist string only. This is tied on the twenty-eighth day after its birth, after which it seldom goes without one. Round the waist and over the perineal band the Nayadis wear a *mundu* or loin-cloth 4 to 5 feet in length and 2 to 2½ feet in breadth. The upper edge is fastened round the waist and the lower edge hangs loose. One of the upper corners, usually that on the right is tucked in and the other hangs out as a small triangular flap (plate v, figs. 2, 3 and 5). Some people prefer to tuck in the left corner, but they are in a minority, as it is not favoured by the upper castes. The flap on the left is used as a pouch to hold odds and ends. When going about during the rainy season, the hanging portion of the loin-cloth is for convenience doubled on itself and the lower edge of the cloth passed somewhat tightly round the hips and the right corner tucked up (plate v, figs. 1 and 2).

A woman's dress is only slightly different from that of a man. Women dispense with the perineal band and have only a single loin-cloth which, however, is usually broader and longer than that of the men. Some of the younger women have a sort of under garment consisting of a small piece of cotton cloth tied round the waist with one corner passed tightly between the thighs and tucked in behind. As among most other Malabar castes, few of the older women have any covering for the upper part of the body. The bodice (*ravukka*) came into vogue in Malabar only a few decades ago, first among the prostitutes in the towns, whence the fashion spread to the villages among the more respectable people. Among Nayadis only the girls of the Kunnamkulam and Olavakkot colonies have bodices (plate iv, figs. 1 and 2).

A Nayadi who becomes a Christian, makes no change in his dress, but conversion to Islam brings about great changes in the convert's attire. The men adopt the close-fitting skull-cap of the Arabs and the women, a close-fitting bodice, a piece of cloth with which to cover the head, and a very broad loin-cloth falling to the heels.

Changes in Fashion.—Under new cultural influences, the shirt appears as an item of dress for the men, as the bodice does for the women. Nayadis with signs of modernness excite prejudice and resentment in the minds of the higher castes, as all who depart from time-honoured norms are bound to do. The objects of resentment anticipate it, but the love of self-improvement subordinates the fear of ridicule and anger. To get over the initial difficulty involved in breaking ancient tradition, the officials in charge of the Government colonies encouraged the Nayadis to put on fashionable dress, and the allowance the colonists received from the Governments reduced their dependence on the charity of the higher castes for their livelihood. When once the initial fears are overcome, the conservative forces represented by the higher castes weaken and the forces tending towards innovation and change gather strength from added numbers. It may not be generally realised that even slight departures from established usage by an inferior caste, for example, the substitution of an umbrella of the European pattern for the old fashioned native palm-leaf umbrella, set in motion a series of psycho-social forces between the caste that effects the innovation

and its immediate superior castes. An individual of a low caste happens sometimes to be powerfully impressed by the æsthetic superiority of the European cloth-umbrella and wants to have one for himself. His elders discourage him by saying, "The cloth-umbrella is not prescribed for us. The Lords will consider you as a very arrogant person and you will bring trouble on yourself." In spite of this warning, sometimes, an umbrella is purchased and used surreptitiously in the beginning, because some busy-body of a higher caste may resent its public appearance, take the law into his own hands and chastise the owner. In cultural matters, in Malabar, the higher castes have the self-arrogated function of conserving the traditional practices of the lower castes and of preventing them from imitating their ways and manners.

Hair-dressing.—The men shave their heads except for a small patch on the crown where the hair is allowed to grow into a tuft called the *kutumi*. The Tamils have the *kutumi* on the occipital part of the head, while those who are indigenous to the Malabar coast have it on the top. Both boys and girls have the *kutumi* to begin with, but the latter, at the age of seven, or somewhat earlier nowadays, stop shaving and grow hair all over the head. Men tie the *kutumi* into a small knot kept most often on the left side. Women tie the hair in a top knot (plate ii, fig. 5), and a modern innovation is to have the knot at the back of the neck. The hair is kept glossy and black by smearing it with coconut or sesamum oil. The blacker the hair, the greater its beauty.

Instead of growing the *kutumi* and keeping it in a knot the younger generation of Nayadis have begun to copy the European style of hair-cutting (plate ii, figs. 3 and 4, plate v, fig. 2) as it has come to them through the higher castes in their immediate neighbourhood. A pair of scissors have, therefore, been added to the barber's outfit which a few families own in common. Between the old fashioned knot of hair and the modern cropped hair there are many intermediate stages. Some men have the *kutumi* clipped short as in plate i, fig. 1. A few individuals grow the hair to a length of ten or twelve inches and tie it in a small knot behind as women do.

Use of Oil.—Men, women and children smear sesamum or coconut oil on their head and body, particularly the head, for both medical and aesthetic reasons. Massaging with oil removes muscular weariness, gives smoothness to the skin and cools the head. "Give to the oil-monger what you give to your doctor" is a common saying which puts in a nutshell the belief of the people of Malabar in the efficacy of these oils. In order to remove the oil various saponine barks and leaves are used. These are mashed with water and used as soap. New born children are bathed after smearing them over with the juice of fresh coconut kernel. The "oil bath" is considered as necessary for healthy life as is good food. The Nayadis are usually too poor to be able to have "oil baths" often. They have mostly to satisfy themselves by smearing on oil in small quantities and it is removed only on

important occasions with the saponine barks. When tooth-ache is supposed to have been brought on by using ordinary oil, it is 'hardened' by boiling it with a piece of broken pottery or some pepper.

Tattooing.—Tattooing, known as 'pricking with green,' is a very common form of decoration on the forehead. A small circular or oval spot is tattooed on the glabella or slightly above it. Tattooing other parts of the body is rare.

Nose Ornaments.—Nose ornaments are nowadays worn by Nayadi women, though they had no ornaments for the nose some years ago. In the Palghat taluk women pierce both the alæ of the nose for their insertion; but elsewhere only the left ala is pierced. Boring is done in the month of *Tulam* (October-November) because the dry east wind that blows during this month helps the healing of the wound. Brass ornaments shaped like a lunette with bead pendants are used occasionally, as also the simple stud or one with the head flattened and with floral designs on it. From the stud a pendant is sometimes suspended (plates ii and iv, figs. ; 62). Nose ornaments are believed to have been introduced into India by the Mohammedans.¹

Ear Ornaments.—The ear lobes of women are enlarged for the insertion of ornaments. Unlike nose-boring, enlarging the ear-lobe is a very ancient practice not only in Malabar but also in other parts of India. The method of boring the ear is described rather fully by Thurston in his "Ethnographic Notes" (pages 369—376). The uncle pierces the ear-lobe with a sharp thorn. The boys have only a small hole bored which does not require any elaborate process. Enlarging of the lobe is effected by inserting cotton or a rolled piece of rag the size of the roll being increased gradually. When the hole is about half an inch in diameter a small cylinder of tamarind wood covered with a leaf of the pepper vine is inserted in it. This cylinder is changed thrice a week for a larger one till the lobe has been enlarged to the required size.

Women have several varieties of wooden and metal ornaments for the ear. It is possible to find a complete evolutionary series of them in a single village group. A simple roll of palmyra² or coconut leaf (plate ix, fig. 5) one or two inches in diameter according to the size of the distended lobe is the simplest and cheapest form of the ear ornament. The leaf scroll is inserted as a compact cylinder of very small diameter which is increased after insertion by pushing against the inner end of the leaf and unwinding it from inside with the fingers of one hand while those of the other hand hold the scroll within the ear-lobe. The tension of the tissue of the lobe keeps the leaf-scroll in position. Even those who do not use the leaf-scroll as an ornament for constant wear find it useful when they want to

¹ Chatterjee, K.N.—J.A.S.B. (N.S.), XXIII, 1927. Some very conservative castes like the Namputiri Brahmins of Malabar forbid the use of nose ornaments by their women. Similarly the lowest castes and the hill-tribes were without nose ornaments until recently.

² In several Sanskrit works, the goddess Kali is described as having the roll of palmyra leaves in her ear-lobes.

enlarge the hole. The next step in the evolution of the ear ornament is an imitation in lead of the leaf-scroll with the addition of a groove for the ear-lobe (plate ix, fig. 6). This ornament is called the *iykola* (lead-leaf). Both lower and upper caste women use it. Its diameter can be increased or decreased as in the case of the leaf scroll. Since lead is heavy, this ornament can be worn only when the lobe is sufficiently strong. A similar scroll is cast in bell-metal when it is called *ottukatti*. The spiral markings on its lateral surface show that the 'lead-leaf' is its precursor. Since the size of the ornament is no longer variable the smith casts the *ottukatti* in sizes varying from 1 inch to 21 inches in diameter. The *toda* marks the highest development of the ear-ornaments in Malabar of the lower castes (plate iv, fig. 2—the girl who sits second from the left has a pair of these ornaments). It consists of two hemispherical or sub-hemispherical halves with a groove between for the string-like lobe of the ear. It may be made either of metal or of clay which is fired incompletely to a dull black colour, but Nayadi women wear only clay *todas* or gold-plated ones, gold ornaments being beyond their means. Rarely wooden plugs with ornamental designs on the stout lateral end are found in use (plate ix, fig. 7). Pulley shaped discs of wood (*Marattoda* = *wooden toda*) with floral designs in gold on a black background (plate ix, fig. 8) are also occasionally used by young women of the colonies run by Government. Old women do not have any ornaments in the ear.

It is of some historical interest to observe that throughout South India both men and women used to enlarge the ear-lobes whereas the practice is now confined to women only. In the numerous Buddhist sculptures of India the men and the women are shown with very large ear-lobes that descend as far down as the shoulders. In Malabar also the larger the lobe of the ear, the more becoming it was considered to be. There has been a progressive decrease in the size of the ear-lobe, though its primitive proportions are still to be seen in the rural areas of Malabar, Madura and Tinnevely Districts.

Nayadi men, old or young, are seldom seen without the simple ear ornament known as the *kadukkan* (plate x, fig. 7). It is a mere oval ring of copper or iron or brass with a swollen middle part. Sometimes it is a mere wire of metal. When a person has no ornament in his ear a small twig is inserted to keep the aperture open, as otherwise there is the risk of the hole in the lobe closing up in course of time.

Neck and Breast Ornament etc.—The following is a list of neck and breast ornaments worn by Nayadi women :—

- 1 Conch shell rings or imitations of them worn as the central piece in bead strings.
The shell is believed to be charm (plate iii, fig. 1).
- 2 Bead strings in several strands.
- 3 Lunette-shaped ornaments of shell worn on the breast (plate x, fig. 5). This is figured in the Census Report for the year 1931, volume I, part 1.
- 4 Bangles of iron worn by children to keep away evil spirits.

- 5 Rings of copper, iron and brass, worn by all. Copper rings are presented to the Nayadis during *Kaladanam* (death-gift).
- 6 Amulet cases, cylinder shaped ornaments filled with a copper leaf containing magical figures or simply a wooden cylinder to keep the hollow metal cylinder intact. There may be a single loop for the string at the top (plate x, fig. 6), or there may be five or seven attached to one side (plate x, fig. 8).
- 7 *Talis.*—Metal plates (usually of brass) with figures cast or embossed on them (plate ix, fig. 4). Imitation coins of brass with ornamented brass loop for string attached to them.

Reclamation of the Nayadis.

Early Work of the Basel Mission.—Christian Missionaries made the first attempt to make respectable citizens of the Nayadis by weaning them from beggary and teaching them the ways of earning a more decent living. The initiative came from the District Collector, Mr. Conolly (who was later murdered in his own house by some fanatical Muhammadans), who established a colony for the Nayadis some time about 1850 near Calicut and gave them land near the town to cultivate. The Basel Mission took over the experiment from the Government authorities, sent the colonists a resident school master, and succeeded in converting and baptizing three of them. The Muhammadans (Moplahs) in the neighbourhood of Calicut wanted to get the Nayadis into the fold of Islam, and as a result of their efforts, all but the three who had been baptized soon left the mission and became Moplahs. Conversion to Islam has a marked effect in freeing the slave castes from the disabilities they have on account of their birth. If an orthodox Hindu, who was in the habit of treating the Nayadi as an untouchable whose approach in any public or private place would defile him, dares to treat him in the same manner after conversion and tries to deny him his civic rights, "the influence of the whole Muslim community comes to the convert's aid." The Christian Missionary has not the same enthusiasm for safeguarding the social rights and privileges of his converts as the Muslim has, but relies more on the protection that he can give them with the help of the Government. Moreover, many Syrian Christians of the Malabar coast observe caste rules to a certain extent, regarding low caste converts as low caste Christians, whereas Muslims insist on the equality of the new and the old sections of the Faithful. Thus the superiority of Islam in Malabar as a proselytising religion made the first efforts of the Basel Mission in the Nayadi cause a failure from the point of view of the mission. The Muslims were not, however, systematic in their service and we hear nothing more of their activities.

Occasional Conversion.—During the next seventy years no organized attempts were made to improve the Nayadis' lot. Both Muslims and Christians got converts sporadically from among them, the Muslims of Ponnani taluk being responsible for converting the largest number. Those living on the estates of Muslims found it usually easy and convenient to adopt the faith of their masters, because by a change of a faith it was possible for them to

work or beg at closer quarters than unconverted Nayadis could do. If even after conversion, some were not able to enjoy all the civic rights of the Muslims, it was chiefly due to their own timidity. Muslim Nayadis are usually called "capped Nayadis," as the skull-cap is a distinguishing mark of the Moplahs. In Cochin State a few individuals and families have become Christians some of whom are doing extremely well in life ; one of the converts is a compounder in a State hospital and has married an Iravan convert. Most of the Christian Nayadis are, however, still beggars and change of faith has been of little practical use to them, as it takes a long time for them to get absorbed into the general body of Christians. I found Muslim Nayadis on the whole more enthusiastic about their new faith than the Christian ; in a discussion between the former and a few Christian converts to which I listened and in which I took sides occasionally, I found that the Muslims felt they were the superior people. I knew two Nayadis, brother and sister, the former Christian, and the latter Muslim, who lived together very amicably in spite of the difference in their faiths, both begging and making ropes, leading the same sort of life as before their conversion. Mere conversion into a new faith, without the psychological changes necessary for better living is, on the whole, futile.

Colony Scheme in Cochin State.—About sixteen years ago when Dewan Bahadur Sir T. Vijayaraghavacharya was Diwan (Chief Executive Officer) of Cochin State, Conolly's plan of reclamation which could not be given a fair trial in Malabar was adopted as the most feasible means of improving the conditions of the depressed classes, including the Nayadis. The present Protector of the Depressed Classes in Cochin State, Mr. V. R. M. Chohan, says in the course of a letter : "As their (Nayadis') numbers increased, begging expeditions to the haunts of civilized men became more frequent, and their vociferous shouts to attract attention and enlist sympathy began to be looked upon as a nuisance to the people, so much so, the Government was forced to take steps to reclaim them. The first step in this direction was taken by Sir T. Vijayaraghavacharya when he was the Diwan of Cochin.....It consisted in establishing settlements in various parts of the State. The first two settlements started were at Kunnankulam and Pazhayannore where lands were acquired for the purpose and a number of houses constructed, and the Nayadis from the neighbourhood were brought and prevailed upon to settle down. They were given small patches of land for raising food crops so as gradually to train them up in rudiments of agriculture. Manual training in weaving and mat making and the like was also given. Free education with one midday meal for the school-going children was also given. Wells have been sunk to supply them with water for drinking purposes. Cleanliness was insisted upon in their daily habits to ensure which among other things free clothing was also given. Besides agriculture and industries, poultry farming was also introduced in the colony. To cater for their religious needs and cravings, *Bhajana Mutts* or Prayer Halls were constructed so as to form part of the equipment of the colony. New colonies continue to be started from time to time in other parts of the

State where a sufficient number of these nomads could be prevailed upon to settle down. These colonies are placed under the charge of honorary wardens who have to look after the well-being of the settlers."

A hut in the Nayadi Colony at Kunnamkulam is seen in the background of plate viii, figure 3. Compared to the very crude huts which they used to make for themselves, the huts at the colony are exceedingly well-built, and the inmates are proud to live there, and feel very grateful to the Government of His Highness the Maharaja for providing them with comfortable habitations. Sita, the sister of Raman, the chief Nayadi of Kunnamkulam (plate v, fig. 3), told me how she used to suffer in her old hut the roof of which leaked during the heavy monsoon rains and she could scarcely protect her babies from being drenched. Unscrupulous neighbours used to rob them of the produce of their small kitchen gardens and deprived them of their little incentive to produce something of their own. At the colony they have now sufficient land to raise minor food crops and grow vegetables. In most places the Nayadis suffer from lack of good wells, and the drinking water which they get is not fit even for cattle. The State Government have very wisely begun with the sinking of wells at the Pazhayannore and the Kunnamkulam colonies. Children are encouraged to attend the State High School near the colony by being paid an anna a day in addition to being given all books and clothing. Adults at the colony are taught how to weave grass mats which have good local demand. Women are assiduously taking to it as also to rope-making. In spite of this, begging remains a major source of income for the Nayadis of this colony, as the doles given by the authorities are regarded as insufficient. It is, however, clear that the atmosphere under which the Nayadis live in the colony under the care of the State is decidedly better than the one to which they were accustomed a few years ago. The younger women have become almost indistinguishable from the rest of Malabar women by wearing the standard dress for their age-class consisting of a bodice in addition to a loin cloth that comes down to the ankle. The use of the bodice is the hall-mark of an advance in culture for these people. The young men and women of the colony are neater, better dressed and more hopeful than the older generation.

Colony Schemes for Malabar Nayadis.—Only very recently did the Government of Madras include the Nayadis in the list of tribes and castes to be protected by the state. The criminal tribes of the Presidency, on the other hand, had long been under the care of the Government since they were a source of danger to other communities. The Nayadis had nothing special about them except their extreme poverty and their lowliness to attract the attention of the Government. When Mr. P. V. Gopalan, a member of the fishermen caste, was appointed Honorary District Labour Officer for the Malabar District, one of his first concerns was the amelioration of the Nayadis. Being himself a member of one of the lower castes, he understood the problems that faced the Nayadis better than officials of upper castes. Mr. Gopalan suggested two schemes to the Government for the improvement of the Nayadis

which were, more or less, modelled on the plans for the uplift of the depressed classes in Cochin State¹, the first being to open a colony for Nayadis adjacent to the Paddy Breeding Station at Pattambi and to employ them as labourers on the farm attached to it, and the second scheme to settle them on coconut farms at Chaliyam owned by the Forest Department where they would engage themselves in coconut cultivation and also find employment in local tile factories.

The Olavakkot Colony.—The Labour Department of the Madras Government accepted part of the suggestions of the Labour Officer and a site for a colony was acquired near the railway station at Olavakkot, in which locality Nayadis were found in large numbers. Nayadis from two adjoining villages were brought to the colony and lodged in five huts. A small elementary school with a Brahmin teacher (plate iv, fig. 2) began the work of teaching the children and the adult men. The scrub jungle extending over some forty acres was cleared and tilled. The colonists were put under the care of a warden who supervises the work on the farm and distributes the rations to all. Begging and drinking were strictly prohibited. Great difficulty was experienced in enforcing 'dry' habits and later the authorities had to allow the colonists to visit the toddy shop occasionally. Men and women were found to get out of the colony on Fridays on the pretext of seeing some relative or other. Friday is the day on which the people in the neighbourhood of the colony give alms to the Nayadis and the warden discovered from the regularity with which relatives fell ill on Fridays that begging was still going on. The old men begged from force of habit and just to add to the available cash that might be spent on toddy. Among the younger Nayadis, however, there is evidence of growing self-respect. They are ashamed of the old profession of begging.

According to the warden of the colony the Nayadis are, as a class, lazy and averse to work. They are clumsy in handling the tools of the agriculturist. The women, however, are giving

¹ The Government of Cochin has adopted for the uplift of depressed classes like the Nayadis a very comprehensive scheme consisting of :—

- 1 Organisation and running of schools for the special benefit of the depressed classes.
- 2 Award of scholarships and stipends both literary and industrial for the promotion of their education.
- 3 Grant of special facilities for collegiate education.
- 4 Provision of feeding and supply of school requisities and cloths.
- 5 Running of hostels for their students.
- 6 Provision of house-sites for the purpose of freeing the depressed classes from oppression by landlords.
- 7 Building up of colonies or settlements.
- 8 Provision of good water for drinking and bathing purposes by sinking wells and tanks and repairing them.
- 9 Provision of pathways, burial-grounds, and sanitary requirements.
- 10 Construction of Bhajana Mutts for religious worship.
- 11 Organisation and running of co-operative societies for the depressed classes.
- 12 Safeguarding the interests of depressed class labour.

It has to be said to the credit of the small State of Cochin that they are attacking the vexed problems of the depressed classes with great vigour. In the district of Malabar administered by the Government of Madras only the fringe of the question has been touched. Instead of the activities of the Labour Officer of the District expanding with the progress of time they have been much curtailed

a better account of themselves than the men. They excel women of the agricultural castes in such work as weeding which requires considerable patience. At the school children and adults are being taught basket-making (plate iv, fig. 3), but it cannot be said yet that they are taking to it. Moreover, in this field, the Parayans who are hereditarily engaged in the trade easily beat them and drive their goods from the market. It will be long before the colony becomes self-supporting on the land that they have now. If the doles of food were stopped, they, like the Nayadis of the Kunnamkulan colony, would revert to begging.

Iravan Reformers' Work at Kuzhalmannam.—In the year 1932, the Iravans of Kuzhalmannam in the Palghat taluk started a home for the Nayadis named after Mr. Carleston, I.C.S., Sub-Collector, who took very keen interest in the latter. The Iravans are themselves suffering from many disabilities because of their caste, but their troubles, though of the same nature as those of the Nayadis, are of milder degree. In their struggle to establish their rights against the traditions maintained by castes superior to them it was useful to begin alleviating the sufferings of the Nayadis also. At Kuzhalmannam, some years ago, a body of Congress men had tried to educate the Nayadis by starting a night school for them, but they gave the attempt up before long. Later the Iravans wanted to get the children of the Nayadis admitted into a school where the children of the other Hindus studied. Since such schools are situated near the quarters used by the highest only, there were some practical difficulties in admitting Nayadi children to those schools. The headmaster of the school, therefore, refused admission to the Nayadi children brought there by the Iravans. The educational authorities to whom an appeal was preferred informed the headmaster that as long as he was receiving aid from the public funds no caste distinctions should be made in the matter of admissions and if the Nayadi children were refused admission to the school the annual grant to it would be withheld. As the year was drawing to a close the headmaster admitted the Nayadi children and received the grant for the year, and then the school was closed for ever. The upper castes regarded it better not to have the school at all than to have Nayadi children under its roof rubbing shoulders with their children.

But the Iravan reformers of Kuzhalmannam did not stop with that. Most of their fellow Iravans have as strong a prejudice against the contact and proximity of the Nayadis as the Nayars and Brahmins have. In getting the Nayadi children admitted into schools the Iravans have as much unwillingness as any other caste in the district. So the courageous band of reformers began to admit the Nayadis into their own houses and to employ them for work on their farms. Though they were of course threatened with ostracism, they persisted in having the Nayadis near them. During the marriage of one of the youngest of the reformers the Nayadis and the friends of the reformers all dined together. Eating together, especially on such an important occasion as marriage, is equal to an admission of equality in status. Inter-dining between Nayadis and Iravans created a sensation. Youths of the Iravan community refused later on to ~~move~~ away from the road or the footpath when they met Nayars

or Brahmins which led to occasional assaults and to criminal suits in the courts. But the courts upheld the fundamental right that a British Indian subject has of using the public thoroughfares.¹

Life in the little village of Kuzhalmannam was greatly disturbed by this struggle between the new spirit and old traditions. The orthodox section of the Iravans themselves connived with the Nayars to compel the reformers to yield to them by using social weapons. The Iravans use members of the Panan caste as their messengers for inviting relatives and friends for marriage and death feasts. Their washermen are of the Vannan caste. The Panans and Vannans were asked not to serve those Iravans who had inter-dined with the Nayadis. These interdictions were in mediæval Malabar the most powerful sanctions in the hands of the heads of the Irvan caste, but now that the old social order is breaking down, they have lost much of their efficiency. The Irvan reformers dispensed with the services of the Panans and were glad of it, because even the Brahmins who are the highest in the land do not employ a caste of messengers, but do such work themselves. They got a new washerman from a neighbouring village. A few decades ago no washerman would have served any group under a social ban.

To ease the communal situation at Kuzhalmannam, Mr. Carleston took the Nayadis along all the main roads of the village, and instructed the village officials that the orthodox elements should be told in clear terms of the Government's determination in the matter of the use of roads by the Nayadis and other low castes. The reformers who described themselves as the Labour Union of Kuzhalmannam published broadcast a printed notice in Malayalam which is translated below :

The Right of the Nayadis.

Not being certain that the recent Government Order establishing the rights of the Nayadis has been brought to the notice of all the public, we hereby make it known to everyone :

“The Nayadis have as much right of using public roads, market places and other public buildings as any other castes, and any one who interferes with their right will be liable for criminal action.”

We are grateful to the Government for the mercy shown to these poor people. If our behaviour to them is affectionate and fraternal, it will help the constitutional future of India.

The next great victory for the reformers at Kuzhalmannam was the returning of Krishnan, one of the young men of the Carleston Nayadi Home, by the local depressed class constituency as a taluk board member. To qualify him as a voter, the reformers transferred some land to him four months before the elections. Krishnan was returned unopposed to the Palghat

¹ This right has not been conceded to the lower castes in some of the South Indian native states.

Taluk Board. He knew how to read and write, but he was too young and inexperienced to understand anything of the objects of the board on which he was to serve. Immediately after the general election members elect their president, and Krishnan who had until recently been begging for alms, was in due course approached by the rival candidates for his support in the presidential election. He was made much of, but needless to say, was a mere puppet in the hands of his patrons of Kuzhalmannam. It gave him the unique opportunity of sitting next to the highest Brahmin in the district and of listening to proceedings of which he understood nothing. Only the travelling allowance he got can have been of any real use to him.

The Manjeri Colony.—An unsuccessful attempt was made in the year 1933 to make the Nayadis independent and self-supporting. Mr. P. Moideenkutti Gurikkal, a philanthropic Mohammedan gentleman of Manjeri in South Malabar, offered to take two families of Nayadis from the Olavakkot settlement who had learnt something of a better mode of life and employ them on his estate and at the same time give them land to cultivate independently as free tenants. He undertook the protection and employment of the Nayadis as a matter of charity. The District Collector, Mr. T. B. Russell, I.C.S., in the course of a speech at the opening of the colony at Manjeri said, "I think this occasion is one of considerable significance for Malabar. Your district may fairly be regarded as a stronghold of the aristocratic tradition. Malabar may well be proud of the contribution of the higher classes towards the welfare of India and the Empire. But there is another side to the picture. While the obligations of the aristocracy in the matter of public service have been well recognized, their obligations to the poor and the oppressed in their own country have not, unfortunately, received the same recognition. Nowhere in India, perhaps nowhere in the world, are the distinctions of class insisted upon so stringently as in Malabar. If one admires her aristocratic traditions, it is at the same time permissible to criticize her innate snobbery. Namputiri, Nayar, Tiyan, Cheruman, Nayadi, one has but to mention the names to realize how intolerant the one class is of the next below it and how that class keeps up the traditions by its intolerance of the next, until at last we get to the unfortunate Nayadi who has nobody but animals to look down upon. I am not one of those who want to stump the country saying that all men are equal. The fundamental inequality of individuals is a fact that must be faced. It seems to me an obligation on the more fortunate to help those who are less favoured—an obligation which is very easily forgotten. Every now and then it happens either that the case of the damned of the earth is brought violently to somebody's notice, or that some individual achieves a wider sympathy and a stronger realization of their plight. Of such is Mr. Moideenkutti Gurikkal who has borne the whole expense of founding this settlement and is making himself responsible for the families housed therein. His generosity is a splendid example of kindness to those who have long been treated as beyond the pale of ordinary human charity. The efforts of a few unselfish workers have shown that these people are not

debarred from the ordinary human heritage and that given opportunity they are capable of rising gradually from their present lowly state”

The two families that were transferred from Olavakkot to the new colony were not willing to leave their friends and relatives and go to a new place several miles away. At the time of taking leave the men and the women wept, but when on their arrival at the Manjeri settlement they saw the nice new tiled huts which the Gurikkal had built for them, they cheered up. They were very kindly treated, given only such light work as they could easily do and paid good wages. Everything went on well for a few days, when something terrible happened which upset the Nayadis completely. One morning a Moplah living near the huts of the Nayadis was found brutally murdered. The unhappy fate of this neighbour, who used to get provisions for them from the bazaar, created such a terror in the minds of the Nayadis that they wanted to leave the place which they thought was too murderous. The local officials tried their best to remove the fear from their hearts, but they failed. Moreover, the place being slightly malarial, most of them got attacks of fever. So the scheme which was initiated under such favourable circumstances, collapsed with the departure of the Nayadis from Manjeri to their ancestral villages, where they reverted to their old mode of living by beggary. And during their absence of three years in the colony at Olavakkot their old huts had fallen in ruins. Those ‘reclaimed’ Nayadis who were sent out from the colony to earn their living thus found themselves in their pre-colony condition, but without the old huts.

The Labour department is looking for broad-minded employers who will give work to the ex-colonists as day labourers on farms or in factories. Many of the local business enterprises are not in a sufficiently thriving condition to enable them to employ the not very efficient Nayadi labour. Caste Hindu employers are, in almost every instance, too narrow-minded and conservative to face the sentimental objection that their upper caste labourers usually have to working side by side with Nayadis.

Nayadis as Labourers on a Government Farm.—Another futile attempt to teach the Nayadis to support themselves was made at the Government Agricultural Research Station at Pattambi in South Malabar, where three Nayadis were sent to work as day labourers on the Government farm. The Superintendent of the station found that the Nayadis always tried to shirk hard work, were slipshod, and irregular in attendance. One morning he found their huts deserted. It must be remembered in this connection that both the District Labour Officer and the Superintendent of the farm were equally eager for the success of their project of making good labourers out of begging Nayadis. The Nayadis are reported to have complained of feeling lonely and home-sick at Pattambi. They were quite satisfied with the wages and the treatment that they received from the officers. But we do not know how the Cherumans and Kanakkans of the locality, who are the guardians of caste orthodoxy so far

as the Nayadis are concerned, reacted to the new situation, namely, the introduction into their midst on an equal footing of members of an inferior caste. Well-intentioned efforts of philanthropists to improve the conditions of the depressed classes have often been frustrated by the local higher castes terrifying the ignorant men and misrepresenting the objects of the social workers.

Establishment of Civic Rights.—To enable the Nayadis to understand their own rights the first step taken by the District Labour Officer in 1929 was to take them in procession along the public roads of the town near the colony, as the custom is for public roads and bazaars not to be used by them when other people are about, and it was therefore necessary firstly to educate the public on the question of the rights on which the Government intended to insist for the Nayadis, thereby introducing an innovation contrary to the traditions of the district ; and secondly, to show the Nayadis that they had such rights and to encourage them to assert them with the authority of the Government behind them. So this small procession of Nayadis headed by the District Labour Officer and the local revenue officials going along the bazaar road of Olavakkot, the railway station premises, and the roads leading to the two opened a new chapter, not only in the history of the Nayadis, but also of caste-ridden Malabar, for that was the first time that members of the lowest of castes in this district trod on soil which their ancestors had not even dreamt of touching. An old man who was one of the processionists told me that he regarded that day's experiences as though they were a dream, that he looked on things that he had not seen before with wondering eyes, and at the same time there lingered in his mind the fear of the vengeance of the *Tampurans* (lords) when the officers left them alone. For several days after this first day's march, the Nayadis were terribly scared and upset. They were afraid of stirring out from their huts ; they did not know who would be preparing to punish them. The men of the town were, however, intelligent enough to accept this new movement for Nayadi emancipation with the hand of the law behind it and therefore, kept quiet, some of them, however, criticising the action of the Government as being rather high-handed. According to the statement of the Nayadis the people who resented the action of the Government most were the local Cherumans. The Cherumans felt that through Government patronage, the first people with whom the Nayadis would claim equality would be themselves, that the Nayadis would refuse to stand aside to allow them to pass unpolluted, and that they would cease to be regarded with the old respect. In the parleys between Nayadis and Cherumans after the procession, the latter are reported to have said, " If the *tampurans* ask you to go against an old custom, why can't you refuse to do so ?" The Cherumans do not also spare any opportunities of ridiculing the Nayadis. The latter are so sensitive to ridicule and so cowardly that the reforms forced on them cost most of them sleepless nights and endless worry.

The railway station at Olavakkot became gradually accessible to the Nayadis and the prejudice against them is now gradually decreasing, though it is unlikely to disappear for decades to come : so deeply ingrained is it in the Hindu mind. There is a large number of orthodox people in all localities who resent any change in caste practices. These people are a constant source of terror to the Nayadis, and make them afraid of venturing out alone into the urban areas. In the year 1930 one of the Nayadis of the Olavakkot colony was the victim of a very serious assault by a Chetti, a railway watchman, who thought he was polluted by the Nayadi's approach. Though the Nayadi was a strong young man able to defend himself, he meekly submitted himself to the Chetti's chastisement. The thought that he should return the blows did not occur to him, because the Chetti was a man of a higher caste. Returning to the colony he reported the incident to the Labour Officer who instituted criminal proceedings in the local Sub-Magistrate's Court against the Chetti and had him fined. The publicity which the case received among their neighbours made the roads safer for the Nayadis.

While the Government were thus actively helping the ameliorative work at Olavakkot, at Pallatheri, a village about six miles away, a Nayar gentleman assumed the role of a patron of the Nayadis and succeeded in taking a batch of them along the main roads with the help of local officials, much to the chagrin of the orthodox Hindus of the village. He also tried to employ them as labourers on his farm, though this was not liked by the Cherumans who formed the bulk of the labour force.

Employment in Public Service and in Factories, etc.—As early as the year 1930 one of the Nayadi young men of the Olavakkot colony, Teyyan by name (plate v, fig. 5), was appointed as an attender in the court of the District Munsif of Palghat. Hindu members of the bar complained that the presence of the Nayadi in the court premises polluted them and the food which they brought for themselves. To the Government this complaint seemed to be the last feeble groan of orthodoxy. Teyyan, as the first Nayadi to be a public servant, became a very important person in the court ; social reformers encouraged public parties in honour of him, the chief object of which was to remove prejudices lingering even in the mind of highly educated people against interdining with Nayadis. The upshot of all this was that caste prejudice was to some extent driven away from the court premises. Teyyan told me, however, that most of his Hindu colleagues had no liking for him and kept aloof from him. A Mohammedan colleague of his was his best friend and helped him to tie the turban and gave him useful advice.

In May 1931, another young Nayadi from the Olavakkot colony was appointed as a peon (attender) in the office of the Deputy Inspector of Schools at Palghat. The Inspector used to take him to all the villages where he had work and the villagers dared not to raise objection to his entry into their schools or to his going along their lanes and footpaths. In Cochin State also a Nayadi was appointed as a peon in the Sub-Registrar's office. The great respect

that the average Hindu has for authority and law greatly facilitates the Government's efforts towards social reform. What private reforming agencies could accomplish only by years of hard work, the Government can do in such matters sometimes in a week. The real opposition to the emancipation of the lowest Hindu castes is from an infinitesimal section of the higher castes. When the lower castes themselves assert their rights those that have to concede them feel they are deprived forcibly of some privileges which they have been enjoying and resent the attempts. It is for this reason that unpleasantness, such as occurred at Kuzhalmannam arises between sections of the Hindu community when coercive measures are adopted to win social rights. When a third party, not necessarily the Government, try to do the same thing, there is much less friction and opposition on account of wounded pride and prestige. The success of some of the Christian missions in alleviating the social disabilities of untouchable castes also lies in the fact that they play the part of middlemen. Employment of members of the lowest castes in public service has been found to be a very effective means of removing the prejudices against them, not only in the case of Nayadis, but also of other castes. In Cochin State, by the employment of low caste men in the police and other services, considerable change has come over their outlook on life, and over the attitude of the higher castes towards them. But unfortunately the number of those who can be benefited by state patronage is necessarily small. Governments can only give the lead and the rest will have to be undertaken by the public themselves.

Conclusion.—Under present circumstances, it will not be practicable to stop Nayadis from begging, because neither the authorities at Kunnamkulam nor those at Olavakkot have funds to bring all the Nayadis under their colony scheme. Without sufficient land to be given free for cultivation the Nayadis cannot hope to become independent farmers. The only hope for them is from the more broad minded and philanthropic farmers who may be induced by the Labour Department to employ them in preference to other labourers. The weakness in the Manjeri project was that the Nayadis who were taken there had to leave their relatives miles away from them, and no consideration was given to the attachment that they have for their kinship group. If an employer like Mr. Gurikkal were found near the Olavakkot colony, the Nayadis would gladly have availed themselves of the opportunity of settling down as free labourers.

When those in charge of Nayadi uplift-work think of new avocations for them, it will be useful to remember the history of the Ulladans of the Cochin coast. These Ulladans came there from the forests of the interior with the help of the men of the plains who went to cut trees for their canoes. Gradually the Ulladans themselves became excellent canoe-makers so that now only their women are usually engaged in begging. Forest herbs have a good demand in the native market and the traditional knowledge that the Ulladans have of the forest flora also stands them in good stead. In the Malabar country, the Nayadis might usefully be started on herb collection and rope making as more suitable avocations than basket making which is now being tried at the school in the Olavakkot colony.

There is nothing evil in the human material provided by the Nayadis. They are not tainted by any criminal tendencies as are the criminal tribes. The Nayadis are in fact one of the mildest of peoples. Some of the Nayadis like Kandan of Karakkad (plate i, figs. 1-4), Sankaran of Kizhoor, and Kandan of Alattur (plate v, fig. 5) are quite intelligent and clever, and given opportunities, they might well have made their mark in any walk of life. They feel that they are the victims of the Hindu social organization which interferes with their freedom wherever they turn. Sankaran asked his landlord, a Nayar, "What justification is there for our children being prevented from attending school and improving their lot as your children do?" But as yet Kandan of Alattur is the only Nayadi who has been able to build a nice tiled house for himself, own a few cattle and cultivate some plots of rice. And he made this modest fortune by carefully husbanding the small amounts that he used to get as doles and lending the money at usurious rates to his own people in the same manner as the Brahmins of the locality, most of whom have usury as their chief business.

PART II. PHYSICAL ANTHROPOLOGY.

Introduction.

Anthropological measurements of the Nayadis were taken by Thurston in 1901. His series consisted of half a dozen individuals and only a summary of the data was published in the Madras Museum Bulletin (Old Series), Vol. IV. Detailed records of Thurston's measurements could not be traced.

The total Nayadi population is only 565 including men, women and children, so the 62 men and 42 women measured include nearly all the adults of moderate age and are quite representative as a sample of the people. The subjects include members of the community in British Malabar and Cochin.

For facilities rendered in obtaining people for measurement, I am indebted to the Protector of Depressed Classes (Mr. Chohan) of the Cochin State and the Labour Officer (Mr. Abraham) of British Malabar.

The technique followed in measurement is the same as that of Dr. B. S. Guha, Anthropologist, Zoological Survey of India, under whom the present writer received his early training in Anthropology. This makes possible the comparison of the data published in the following pages with those of the Anthropological Bulletins of the Zoological Survey of India and the Anthropometric section of the Census Report of India (1931), Vol. I, part III.

The writer had the opportunity of comparing and checking his technique with that of Dr. Kraus of Upsala, who is extremely keen on standardization, and also those of Prof. Theodor Mollison at Munich and Prof. Fleure at the Royal Anthropological Institute, London. Dr. Kraus and Prof. Mollison follow Martin closely, but Prof. Fleure had an entirely different technique and had his own special set of instruments. Both at Calcutta and at Madras the technique is almost identical with that of the continental anthropologists, except perhaps in the matter of 'pressure' applied at the landmarks.

The charts for recording measurements and observations were supplied by Dr. B. Prashad, Director of the Zoological Survey of India. Hermann and Rickenbach's anthropometric instruments were used for measurements, and for recording skin-colour, eye-colour and hair-colour, Von Luschan's Hautfarbentafel, Martin's Augenfarbentafel and Fischer's Haarfarbentafel, respectively.

Measurements Taken.—(The numbers within brackets are reference numbers of Martin in his *Lehrbuch der Anthropologie*, Vol. 1.)

- | | |
|--|---|
| <ul style="list-style-type: none"> 1 Stature (No. 1, page 150, Martin). 2 Auricular height (15) (Head height obtained by direct measurement with the last segment of the anthropometer yielded better results than that obtained by subtracting height up to the tragus from stature). 3 Head length (No. 1). 4 Head breadth (No. 3). 5 Minimum frontal breadth or diameter (No. 4). 6 Maximum bizygomatic breadth (No. 6). 7 Bigonial breadth (No. 8). | <ul style="list-style-type: none"> *8 Inter-orbital breadth (No. 9). 9 Nasal height (length) (No. 21). 10 Nasal breadth (No. 13). 11 Nasal depth (No. 22). *12 Orbito-nasal breadth [No. 10 (1)]. *13 Orbito-nasal arc [No. 10 (2)]. 14 Upper facial length (No. 20). 15 Total facial length (No. 18). 16 Horizontal circumference of the head (No. 45). 17 Sagittal arc of the head (No. 48). 18 Transverse arc of the head (No. 49). |
|--|---|

Observations Made—

- | | |
|--|--|
| <ul style="list-style-type: none"> 1 Skin colour. 2 Hair colour and distribution of hair. 3 Hair form. 4 Eye colour and shape, Epicanthic fold. 5 Nose form. 6 Forehead. | <ul style="list-style-type: none"> 7 Supra-orbital ridge. 8 Prognathism. 9 Lips. 10 Chin. 11 Ears. 12 Teeth. |
|--|--|

General Conclusions.

As will be seen from the accompanying table, in most of their physical characters as in their caste status, the Nayadis are midway between the hill tribes and the castes of the plains. Estimated cranial capacity shows that they belong to the microcephalic group. They are not lower in stature than the Cherumans and the Iravans, (Iluvans) both castes of the plains, but are distinctly low compared to the Nayars and the Namputiris who are of the higher castes. In cephalic index the Nayadis are indistinguishable from the rest of Malabar castes, all being dolicocephalic. There is, however, a very significant difference when the nasal index is taken into consideration, the Nayadis being more platyrrhine than the Cherumans and the Iravans, but less than the Paniyans of the Wynad hills. In non-mensurable characters such as skin colour, etc., this intermediate position is maintained. Though the figures do not reveal it sufficiently, there is present among the Nayadis a very

* Modified in accordance with the suggestion of Oldfield Thomas (pages 332-334, Martin). See Guha, "Census of India" (1931), Vol. I, part III-A, page vi.

small percentage of individuals relatively shorter in stature and darker in complexion and with broader face than the rest, closely resembling the Veddoid primitive (plate iii, fig. 2).

Table I.—Comparison of stature, cephalic and nasal indices of the Nayadis with neighbouring castes and tribes in Malabar.

Tribes and castes (Males only).	Stature.	Cephalic Index.	Nasal Index.	Author.
Nayadi	1,597 mm.	73·7	85·6	Aiyappan.
	1,550 „	74·8	85·8	Thurston.
Paniyan	1,574 „	74·0	95·1	Fawcett.
	1,565 „	73·3	84·5	Eickstedt.
Cheruman	1,575 „	73·9	78·1	Thurston.
Iluvan (Iraivan)	1,596 „	72·7	82·5	Thurston.
	1,594 „	73·3	75·2	Guha.
Tiyer (Tiyān)	1,637 „	72·7	75·0	Fawcett.
	1,609 „	75·4	70·4	Eickstedt.
Nayar	1,656 „	73·1	76·8	Fawcett.
	1,689 „	74·1	72·3	Guha.
Namputiri	1,635 „	72·5	72·2	Guha.

Measurements.

Stature.

	Males.	Females.
	c.m.	c.m.
Minimum	147	132
Maximum	169	159
Mean	159·74 ± '44	146·02 ± '56

(Standard deviations, coefficients of variation, etc., are given in General Table I, p. 123.)

From the table below it will be seen that the great majority of both men and women belong to the 'short' group (Martin).

Table II.—Frequency of Stature Groups.

Class.	62 males.		42 females.			
	Frequency.	Percentage.	Class.	Frequency.	Percentage.	
Very short	— 1499 mm.	2	3·2	— 1399 mm.	5	11·9
Short	1500-1599 „	25	40·3	1400-1489 „	26	61·9
Below medium	1600-1639 „	21	33·9	1490-1529 „	5	11·9
Medium	1640-1669 „	7	11·3	1530-1559 „	4	9·5
Over medium	1670-1699 „	7	11·3	1560-1589 „	2	4·8

The Nayadis are only slightly taller than the jungle folk who inhabit the neighbouring forests to the east; they are almost indistinguishable from the Cherumans who constitute their immediately superior caste, and also from the Tiyan who are considerably higher in social gradation. The women are taller than Paniyan and Kadir (Kadar) women and very closely approximate the Tiyan women in stature.

The following table shows the intermediate position in stature of the Nayadis between the jungle tribes and the upper caste Nayars of the plains :—

Table III.—Comparison of Stature.

Tribe or Caste.						Male.	Female.
						c.m.	c.m.
Jungle tribe—							
Paniyan	156.5	143.9
Kadir (Kadar)	157.7	143.0
Veddahs	156.1	...
Plains castes—							
Cheruman	157.5	...
Iravan	159.6	...
Tiyan	160.9	147.6
Nayar	165.2	...

Head Length.

						Males.	Females.
						mm.	mm.
Minimum	167	161
Maximum	192	186
Mean	181.53±.49	173.12±.58

Table IV.—Comparison of Head Length.

Tribe or Caste.						Minimum.	Maximum.	Average.
						mm.	mm.	mm.
Paniyan	175	193	184
Kadar	172	194	184
Cheruman	175	193	184
Tiyan	178	203	189
Nayar	174	198	187

The Nayadis have a relatively shorter absolute mean head length, a lower minimum and maximum than all the other castes of the plains and also the jungle tribes in the neighbouring area.

<i>Head Breadth.</i>						Males.	Females.
						mm.	mm.
Minimum	125	122
Maximum	140	140
Mean	133'4±'27	129'21±'45

Table V.—Comparison of Head Breadth (males only).

Tribe or Caste.				Minimum.	Maximum.	Average.
				mm.	mm.	mm.
Paniyan	130	149	136
Kadar	125	138	134
Cheruman	123	142	135
Tiyan	126	149	137
Nayar	132	150	139

As in the case of head length the absolute breadth of the Nayadi head is also lower than that of the neighbouring castes and forest tribes. In other words the Nayadis have the smallest sized cranium taking only the length and breadth of the head into consideration and taking for granted for the time being that the amount of hypsicephaly which characterises almost all the castes in South India is equal in the tribes and castes compared.

Head Height (Auricular Height).

Mollison's parallelometer which is the best instrument for measuring head height was not available at the time of the field work in connexion with the present study. Some experience in the field showed that the head height was more accurately taken directly with the last section of the anthropometer used as calipers instead of obtaining it by subtraction of height up to the tragus from the stature taken by the anthropometer. The high coefficient of variation for head height is obviously due to the unsatisfactory condition of the technique employed. The average of direct measurements of heights from both the right and left tragus points was taken in most cases.

						Males.	Females.
						mm.	mm.
Minimum head height	103	101
Maximum	135	134
Mean	120'45±'56	115'19±'67

No data are available for other neighbouring castes for the comparison of this character and those that follow.

Minimum Frontal Breadth.

					Males.	Females.
					mm.	mm.
Minimum	87	87
Maximum	104	100
Mean	96.95 ± .29	94.21 ± .38

Maximum Bizygomatic Breadth (Face Width).

					Males.	Females.
					mm.	mm.
Minimum	117	110
Maximum	135	128
Mean	126.26 ± .34	117.64 ± .43

Bigonial Breadth.

					Males.	Females.
					mm.	mm.
Minimum	86	82
Maximum	109	100
Mean	98.99 ± .45	91.88 ± .41

Inter-Orbital Breadth.

					Males.	Females.
					mm.	mm.
Minimum	24	25
Maximum	36	35
Mean	29.40 ± .23	28.83 ± .21

Nasal Height (Length).

					Males.	Females.
					mm.	mm.
Minimum	38	35
Maximum	51	45
Mean	44.97 ± .24	40.07 ± .29

Nasal Breadth.

					Males.	Females.
					mm.	mm.
Minimum	33	32
Maximum	44	39
Mean	38.76 ± .20	35.27 ± .21

Nasal Depth.

				Males.	Females.
				mm.	mm.
Minimum	13	12
Maximum	2	18
Mean	16.628 ± .15	15.20 ± .18

Orbito-Nasal (Biocular) Breadth.

				Males.	Females.
				mm.	mm.
Minimum	80	71
Maximum	96	92
Mean	88.03 ± .33	85.18 ± .45

Orbito-Nasal Arc.

				Males.	Females.
				mm.	mm.
Minimum	88	80
Maximum	110	105
Mean	98.38 ± .44	92.82 ± .54

Upper Facial Length.

				Males.	Females.
				mm.	mm.
Minimum	54	50
Maximum	70	69
Mean	61.97 ± .29	58.28 ± .44

Total Facial Length.

				Males	Females.
				mm.	mm.
Minimum	91	86
Maximum	116	107
Mean	103.74 ± .42	95.23 ± .59

The Arcs and Circumference of the Head.

The sagittal and transverse cephalic arcs and the horizontal cephalic circumference were taken in most cases, but as most of the subjects, men and women, had very dense growth of long hair, keeping the steel tape in position in the proper planes and in close contact with the scalp was always difficult. All the data obtained are recorded in General Table II. Care was taken in all cases to remove the hair as far as possible and expose the scalp in the planes of the sagittal, transverse, and the glabella-opisthocranial lines.

Indices.

Length-Breadth Index of the Head.

	Males.	Females.
Minimum	67	68
Maximum	81	82
Mean	73.73 ± .23	74.55 ± .31

Table VI.—Frequency of Head Types in the sample.

Class.	62 Males.		42 Females.	
	Frequency.	Percentage.	Frequency.	Percentage.
Dolicocephalic, α —75.9	49	79.03	29	69.05
Mesocephalic, 76.0—80.9	12	19.35	11	26.19
Brachycephalic, 81.0—85.4	1	1.61	2	4.76

The cephalic index of the Nayadis according to Thurston is 74.8, but his sample consisted of less than a dozen males only. The presence of a high percentage of mesocephals among the women is a point of interest.

Length-Height Index of the Head.

	Males.	Females.
Minimum	59	61
Maximum	72	75
Mean	66.37 ± .27	66.60 ± .36

Table VII.—Frequency of Head Types in the sample.

Class.	62 Males.		42 Females.	
	Frequency.	Percentage.	Frequency.	Percentage.
Chamaecephalic, α —57.6	0	0	0	0
Orthocephalic, 57.7 — 62.5	10	16.13	4	9.52
Hypsicephalic, 62.6 — α	52	83.87	38	90.48

The very high cranial vault of people of South India has been noted by several craniometricians, particularly Turner. It was only very recently however that in somatological studies the height of the head and the length-height index have begun to receive attention. The distribution of hypsicephaly in the population of India is bound to be of very great interest, but as yet the data available for comparison is very little. Extreme hypsicephaly characterises the Nayadis both male and female, the latter having it in a more pronounced manner.

Breadth-Height Index of the Head.

	Males.	Females.
Minimum	80	75
Maximum	100	101
Mean	89.97 ± .41	88.79 ± .53

Table VIII.—Frequency of Cranial Types in the sample.

Class.	62 Males.		42 Females.	
	Frequency.	Percentage.	Frequency.	Percentage.
Tapeino cephalic, $x-78.9$	0	0	2	4.76
Metrocephalic, $79-84.9$	9	14.52	6	14.29
Akrocephalic, $85-x$	53	85.48	34	80.95

Transverse Fronto-Parietal Index.

	Males.	Females.
Minimum	65	66
Maximum	80	79
Mean	72.55 ± .23	72.93 ± .30

Table IX.—Frequency of Grades in the Transverse Fronto-Parietal Index.*

Class.	62 Males.		42 Females.	
	Frequency.	Percentage.	Frequency.	Percentage.
Stenometopic, $x-66.9$	1	1.61	1	2.38
Metriometopic, $67.0-69.9$	8	12.90	7	16.67
Eurymetopic, $70-x$	53	85.48	34	80.95

Nasal Index.

	Males.	Females.
Minimum	69	73
Maximum	100	105
Mean	85.68 ± .55	88.34 ± .81

Table X.—Distribution of Types of Nose Forms.

Class.	62 Males.		41 Females.	
	Frequency.	Percentage.	Frequency.	Percentage.
Leptorrhine, $55-69.9$	1	1.61	0	...
Mesorrhine, $70-84.9$	27	43.55	14	34.15
Chamaerhine, $85-99.9$	30	48.39	21	51.22
Hyperchamaerhine, $100-x$	4	6.45	6	14.63

* The classes given by Martin (Lehrbuch, 2nd volume, page 652) are for the cranium. To allow for the increase in the living one has been added here to each class of the cranial indices.

Table XI.—Comparison of the Nasal Index of the Nayadis with those of neighbouring Castes (males only).*

Tribe or Caste.	Minimum N.I.	Maximum N.I.	Average of N.I.
Paniyan	72.9	108.6	95.1
Kadar	72.9	115.4	89.8
Cheruman	69.6	88.9	78.1
Tiyan	61.5	85.7	74.2
Nayar	54.4	78.7	71.1

The Nasal Index for Nayadi males obtained by Thurston for his very small series was 85.8 which agrees very closely with the above figure for males.

The Nasal Indices for Tiyan and Paniyan obtained by Fawcett in 1905 and nearly twenty-three years later by Von Eickstedt do not agree ; similarly those for Iravans (Iluvans) and Nayars given by Thurston, Fawcett and Guha show a good deal of divergence ranging from 7 in the case of Iravans to 4 in the case of Nayars. The difference between Fawcett's and Eickstedt's Nasal Indices of the Paniyans is 10.6, a figure too high to be the result of only a difference in technique. The figures of Eickstedt and Guha are lower than Thurston's in all the instances cited. Since the nasal index is an important character for racial classification it has been necessary to point out this defect in the data of Thurston and of Fawcett.

The Nasal Index of the Nayadis is intermediate between those of the primitive jungle folks, the Paniyans and the Kadars on the one hand, and the plains castes such as the Nayars, Tiyan and Cherumans on the other, quite in conformity with their position in the caste hierarchy, thus definitely supporting Risley's well-known generalisation regarding the correlation between Nasal Index and caste status as being inversely proportional.

Another fact revealed by the present study is that Nayadi women tend to be more platyrrhine than their men.

Nasal Elevation Index.

	Males.	Females.
Minimum	32	33
Maximum	56	51
Mean	43.23 ± .45	42.8 ± .49

Nasal Length-Depth Index.

	Males.	Females.
Minimum	26	29
Maximum	48	44
Mean	37.11 ± .32	38.0 ± .39

* Figures from Thurston.

Superior Facial Index.

	Males.	Females.
Minimum	44	42
Maximum	57	56
Mean	48.97 ± .24	48.82 ± .35

Table XII.—Frequency of Face Types.

Classes.	60 Males.		40 Females.	
	Frequency.	Percentage.	Frequency.	Percentage.
Hypereuryene, $x - 42.9$	0	0	1	2.50
Euryene, 43 — 47.9	20	33.33	11	27.50
Mesene, 48 — 52.9	33	55.00	19	47.50
Leptene, 57 — x	7	11.67	9	22.50

The Superior Facial Index and the Total Facial Index show that the Nayadi face tends on the whole to be below medium length.

Total Facial Index.

	Males.	Females.
Minimum	72	71
Maximum	94	91
Mean	82.1 ± .39	80.83 ± .47

Table XIII.—Grades of Total Facial Index in the sample.

Class.	61 Males.		41 Females.	
	Frequency.	Percentage.	Frequency.	Percentage.
Hypereuryprosopic, $x - 78.9$	13	21.31	12	29.27
Euryprosopic, 79 — 83.9	29	47.54	19	46.34
Mesoprosopic, 84 — 87.9	12	19.67	7	17.07
Leptoprosopic, 88 — 92.9	5	8.20	3	7.32
Hyperleptoprosopic, 93 — x	2	3.28

Zygo-Mandibular Index.

	Males.	Females.
Minimum	71	71
Maximum	93	82
Mean	79.05 ± .40	78.05 ± .27

Zygo-Frontal Index.

	Males.	Females.
Minimum	72	73
Maximum	85	87
Mean	77.23 ± .24	80.19 ± .23

The Zygo-Mandibular Index shows that the face below the zygomatic arches is shaped almost alike in the men and the women. The Zygo-Frontal Index on the other hand indicates that the women have somewhat broader frontal region or in other words their Zygo-matic arches project less from the frontal region than in the case of the men.

Transverse Cephalo-Facial Index.

	Males.	Females.
Minimum	88	87
Maximum	101	97
Mean	94.42 ± .24	91.19 ± .70

Analysis of Non-measurable Characters.

Skin Colour.

Von Luschan's Hautfarbentafel was used for helping observations on and record of skin colour, though its use presents considerable difficulty in practice. Since the subjects both male and female go about semi-naked, the body colour is the same in the areas where differences due to effects of exposure are usually noted.

Though no accurate figures are available for comparison, one easily finds that the Nayadis are slightly lighter in skin colour than the jungle tribes, but are darker than other dwellers of the plains.

Table XIV—Skin Colour of the Forehead.

Colour No. (Von Luschan).	62 Males.		41 Females.	
	Frequency.	Percentage.	Frequency.	Percentage.
25	1	1.62
26	2	3.23
27	3	4.84	1	2.44
28	2	3.23	2	4.88
29	8	12.90	11	26.83
30	34	54.84	21	51.22
31	3	4.84	3	7.32
32	8	12.90	3	7.32
34	1	1.61

Table XV.—Skin Colour—Upper Arm.

Colour No. (Von Luschan).	62 Males.		41 Females.	
	Frequency.	Percentage.	Frequency.	Percentage.
25	1	1·61
26	1	1·61
27	1	1·61
28	1	1·61	1	2·44
29	12	19·35	14	34·15
30	24	38·71	17	41·46
31	8	12·90	3	7·32
32	9	14·52	4	9·76
33	3	4·84	2	4·88
34	2	3·23

Head Hair.

The characteristic form of head hair is flat (low) wavy, and the colour deep black (Nos. 27 and 28 of Dr. Fischer's Haarfarbentafel). Since the Nayadis, like other Indian people, oil their hair very frequently to keep it glossy and in order, and as deep black hair is believed to improve appearance, unless special care is taken to remove the oil, true hair colour is not obtained. The transition from grade 27 to 28 on Fischer's scale is brought about by oiling.

A slight reddish brown colour was visible towards the tip of the hair in some individuals measured and particularly in some children. Slight degrees of erythrim in the hair has been recorded for the Brahmans and the Nayars of Malabar¹. Hrdlicka observes that in the case of the Sioux² the brown tinge was due to the action of the alkali in cheap soap used by the children at school. Chatterjee who observes a lighter shade in the dark-haired Brahmans of Behar thinks it to be due to the effects of exposure.³ Exposure to heat and bright sunlight is popularly believed to have the effect of bleaching the hair, but this belief requires experimental verification. It is difficult to assign any ready-made reasons for the appearance of this peculiarity, which is in some instances handed down from parents to children. Dr. Guha's recent researches show that the reddish brown tint (Nos. 4 and 5 of Fischer's scale) is common in the hair of Namputiris (16 per cent of his sample), Iravas (26 per cent) and Tamil Brahmans (55 per cent).⁴ It is also found in the hair of some black people like the

¹ J. Beddoe "Colour and Race", *J.R.A.I.*, Vol. XXV, 1905.

² A. Hrdlicka "Anthropology of the Sioux." *Am. Jour. of Phy. Anth.*, Vol. XVI, 1931-32.

³ B. K. Chatterjee, "Maithil and Kanauja Brahmans of Behar." *Anthro. Bull. Zool. Surv. of India*, No. II, 1934.

⁴ See Laws of Manu, III, 6 (Sacred Books of the East, Vol. XXV, p. 76) where it is said "Let him [the twice-born] not marry a maiden (with) reddish hair." Dark hair is a point of beauty according to classical Sanskrit authors. See also p. 87 of Part I.

Papuans of New Guinea. Samples of Veddah hair from burials sent to us by Prof. W. O. Hill of the Medical College, Colombo, were reddish brown in colour. The effect of long burial has been to turn the black hair of the Veddahs to brown.

Table XVI.—Hair Form.

	60 Males.		41 Females.	
	Frequency.	Percentage.	Frequency.	Percentage.
Straight	2	3·33	5	12·20
Low waves	35	58·33	31	75·61
Deep waves	7	11·67	3	7·32
Curly	16	26·67	2	4·88

Table XVII.—Quantity of Hair on the Head.

	61 Males.		39 Females.	
	Frequency.	Percentage.	Frequency.	Percentage.
Slight	8	13·11	2	5·13
Moderate	43	70·49	32	82·05
Marked	10	16·39	5	12·82

Body Hair.

Observations were made on males only.

Table XVIII.—Body Hair.

	62 Males.	
	Frequency	Percentage.
Bare	13	20·97
Slight	43	69·35
Moderate	6	9·68

Table XIX.—Beard and Moustaches.

	62 Males.	
	Frequency.	Percentage.
Bare	4	6·45
Slight	38	61·29
Moderate	20	32·26

Eye Colour and Shape.

Table XX.—Eye Colour.

Number according to Martin's Augenfarbentafel.	60 Males.		39 Females.	
	Frequency.	Percentage.	Frequency.	Percentage.
1	14	23·33	18	46·15
1-2	6	10·00	3	7·69
2	35	58·33	16	41·03
2-3	3	5·00	2	5·13
3	1	1·67
7	1	1·67

The lightness in eye colour of one individual (No. 7 of Martin's scale) is pathological. Similarly in a couple of women, the lightness (2-3) is due to disease. In a majority of cases the sclera is not clear. The number of men, women and children who are night-blind is very considerable. Their wanderings in the course of their daily begging tours exposed to heat and glare may account for the great incidence of this disease.

There is very little variation in the shape of the eye, it being almond shaped in all cases.

A slight trace only of the epicanthic fold was observed in a woman (plate iii, fig. 2).

Nose.

Table XXI.—Nose Form.

	61 Males.		41 Females.	
	Frequency.	Percentage.	Frequency.	Percentage.
Straight	49	80·33	15	36·59
Convex	6	9·84	15	36·59
Concave	6	9·84	11	26·83

Table XXII.—Root of the Nose.

	60 Males.		41 Females.	
	Frequency.	Percentage.	Frequency.	Percentage.
Not depressed	11	18·33	25	60·98
Slightly depressed	24	40·00	13	31·71
Moderately depressed	18	30·00	3	7·32
Strongly	7	11·67

Forehead.

Table XXIII.—Forehead—Height.

	62 Males.		41 Females.	
	Frequency.	Percentage.	Frequency.	Percentage.
Low	11	17.74	14	34.15
Medium	45	72.58	25	60.98
High	6	9.68	2	4.88

Table XXIV.—Forehead—Breadth.

	62 Males.		41 Females.	
	Frequency.	Percentage.	Frequency.	Percentage.
Narrow	15	24.19	13	31.71
Medium	47	75.81	28	68.29

Table XXV.—Forehead—Slope backwards.

	61 Males.		38 Females.	
	Frequency.	Percentage.	Frequency.	Percentage.
Nil	19	31.15	34	89.47
Slight	28	45.90	4	10.53
Medium	14	22.95	0	...

Table XXVI.—Supra-Orbital Ridge.

	61 Males.		Females.
	Frequency.	Percentage.	
Slight	34	55.74	All weak.
Moderate	24	39.34	
Strong... ..	3	4.92	

Face.

Table XXVII.—Alveolar Prognathism.

	57 Males.		34 Females.	
	Frequency.	Percentage.	Frequency.	Percentage.
Nil	27	47.37	20	58.82
Slight	11	19.30	6	17.65
Medium	16	28.07	8	23.53
Very Strong	3	5.26	0	...

Table XXVIII.—Lips.

	62 Males.		39 Females.	
	Frequency.	Percentage.	Frequency.	Percentage.
Thin	1	1·61	6	15·38
Medium	46	74·19	27	69·23
Thick	15	24·19	6	15·38

Table XXIX.—Chin.

	61 Males.		40 Females.	
	Frequency.	Percentage.	Frequency.	Percentage.
Feebly developed	22	36·07	28	70·00
Medium	32	52·46	9	22·50
Prominent	7	11·48	3	7·50

Teeth.

Diseases of the teeth are extremely common. Very few of the old people retain their teeth after sixty. In the case of younger people of about forty, the incisors are worn out to the neck. Teeth are only of moderate size and the bite normal.

Sexual Differences in Bodily Characters.

Various races do not show the same degree of sexual variation in most of their physical characters. In his study of Negro crania Hrdlicka (Catalogue of Human Crania, 1928) found that the supraorbital ridges were ill-developed in the male with the result that the sexes could not be easily distinguished with the help of this particular character. He also found that the muscular attachments on female crania were almost masculine in their development. In the study of sex differences in the various sections of South Indian population one is handicapped by the paucity of physical measurements taken on women and therefore no comparison is attempted here. In table XXX (below) the percentile relation of sexes in some of their mensurable physical characters is given. In non-mensurable characters the women have, as a rule, darker iris, less depressed and more smoothly arched nasion region, less prognathous face, less developed supra-orbital ridges and less prominent chins than their men-folk.

Table XXX.—Comparison of Sexes—Measurements and Indices.

	Males.	Females.	Percentile relation, Males = 100.
<i>(a) Measurements—</i>			
	mm.	mm.	
Stature	1,600	1,460	91.25
Head length	182	173	95.05
Head breadth	133	129	96.99
Head height	120	115	95.83
Minimum frontal diameter	97	94	96.91
Maximum bizygom. breadth	126	118	93.65
Bigonial breadth	99	92	92.93
Inter-orbital breadth	29	29	100.00
Nasal length (height)	45	40	88.89
Nasal breadth	39	35	89.74
Nasal depth	17	15	88.24
Orbito-nasal breadth	88	85	96.59
Superior facial length	62	58	93.55
Total facial length	104	95	91.35
<i>(b) Indices—</i>			
Cephalic	74	75	101.35
Length height index of head	66	67	101.52
Breadth height index	90	89	98.89
Transverse fronto-parietal	73	73	100.00
Nasal	86	88	102.33
Nasal elevation	43	43	100.00
Nasal length depth	37	38	102.70
Superior facial	49	49	100.00
Total facial	82	81	98.78
Zygo-mandibular	79	78	98.73
Zygo-frontal	77	80	103.90
Cephalo-facial	94	91	96.81

PART III
APPENDICES AND INDEX

APPENDIX I

General Table I.—Means, Standard Deviations and Coefficients of Variation with their P.E.

	Male.			Female.		
	Mean.	Standard Deviation.	Coefficient of Variation.	Mean.	Standard Deviation.	Coefficient of Variation.
Stature ...	159.74 ± .44	5.19 ± .31	3.25 ± .20	146.02 ± .56	5.41 ± .40	3.71 ± .27
Head length ...	181.53 ± .49	5.73 ± .35	3.16 ± .19	173.12 ± .58	5.53 ± .41	3.20 ± .24
Head breadth ...	133.44 ± .27	3.36 ± .19	2.52 ± .15	129.21 ± .45	4.29 ± .32	3.32 ± .24
Head height ...	120.45 ± .56	6.58 ± .40	5.46 ± .33	115.19 ± .67	6.40 ± .47	5.55 ± .41
Minimum frontal diameter ...	96.95 ± .29	3.35 ± .20	3.45 ± .21	94.21 ± .38	3.66 ± .27	3.88 ± .29
Maximum bizygomatic breadth ...	126.26 ± .34	3.97 ± .24	3.15 ± .19	117.64 ± .43	4.17 ± .31	3.55 ± .26
Bigonial breadth ...	98.99 ± .45	5.16 ± .31	5.21 ± .32	91.88 ± .41	3.94 ± .29	4.29 ± .32
Inter-orbital breadth ...	29.40 ± .23	2.66 ± .16	9.03 ± .55	28.83 ± .21	2.04 ± .15	7.06 ± .53
Nasal length (height) ...	44.97 ± .24	2.77 ± .17	6.15 ± .37	40.07 ± .29	2.75 ± .20	6.85 ± .51
Nasal breadth ...	38.76 ± .20	2.42 ± .15	6.24 ± .38	35.27 ± .21	1.98 ± .15	5.60 ± .42
Nasal depth ...	16.68 ± .15	1.78 ± .11	10.64 ± .64	15.20 ± .18	1.71 ± .13	11.27 ± .84
Orbitonasal breadth ...	88.03 ± .33	3.86 ± .24	4.39 ± .27	85.18 ± .45	4.25 ± .32	4.99 ± .38
Superior facial length ...	61.97 ± .29	3.32 ± .21	5.36 ± .33	58.28 ± .44	4.14 ± .31	7.10 ± .54
Total facial length ...	103.74 ± .42	4.87 ± .30	4.69 ± .29	95.23 ± .59	5.50 ± .41	5.78 ± .44
<i>Indices.</i>						
Cephalic ...	73.73 ± .23	2.73 ± .17	3.70 ± .22	74.55 ± .31	2.93 ± .22	3.93 ± .29
Length-height index of head ...	66.37 ± .27	3.16 ± .19	4.77 ± .29	66.60 ± .36	3.49 ± .26	5.24 ± .39
Breadth-height ...	89.97 ± .41	4.73 ± .29	5.25 ± .32	88.79 ± .53	5.11 ± .38	5.75 ± .42
Transverse fronto-parietal ...	72.55 ± .23	2.70 ± .16	3.72 ± .23	72.93 ± .30	2.91 ± .21	4.00 ± .29
Nasal ...	85.68 ± .55	6.33 ± .39	7.40 ± .46	88.34 ± .81	7.65 ± .56	8.66 ± .64
Nasal elevation ...	43.23 ± .45	5.23 ± .32	12.09 ± .73	42.80 ± .49	4.58 ± .35	10.70 ± .81
Nasal length-depth ...	37.11 ± .32	3.70 ± .22	9.98 ± .60	38.00 ± .39	3.68 ± .27	9.67 ± .72
Superior facial ...	48.97 ± .24	2.78 ± .17	5.68 ± .36	48.82 ± .35	3.31 ± .25	6.64 ± .50
Total facial ...	82.10 ± .39	4.43 ± .27	5.40 ± .33	80.83 ± .47	4.49 ± .33	5.55 ± .41
Zygo-mandibular ...	79.05 ± .40	4.62 ± .28	5.84 ± .35	78.05 ± .27	2.59 ± .19	3.32 ± .24
Zygo-frontal ...	77.23 ± .24	2.76 ± .17	3.58 ± .22	80.19 ± .23	2.20 ± .16	2.74 ± .20
Cephalo-facial ...	94.42 ± .24	2.76 ± .17	2.92 ± .18	91.19 ± .70	6.68 ± .49	7.33 ± .54

General Table II-A.—Personalia, Measurements, Indices and Observations on Men.

Serial number.	Number in the observation sheets.	Personalia.			Measurements—mm.											
		Name.	Age.	Birth-place.	Taluk.	Stature (1)	Head-length (2)	Head-breadth (3)	Auricular height (4)	Min. front-breadth (5)	Bizygom. breadth (6)	Bigonial breadth (7)	Inter-orbital breadth (8)	Nasal length (9)	Nasal breadth (10)	Nasal depth (11)
1	1	Ayyappan	...	Kunnankulam.	Cochin State.	1,539	185	136	124	101	130	107	31	48	39	14
2	2	Sankaran	...	Do.	Do.	1,515	175	133	113	95	123	97	29	40	36	15
3	3	Raman	...	Do.	Do.	1,552	188	140	113	99	135	103	26	45	38	19
4	4	Kandan	...	Olavakkot	Palghat	1,552	185	139	124	99	129	100	36	47	40	18
5	5	Rekkan	...	Do.	Do.	1,578	177	133	125	95	129	96	29	48	42	18
6	6	Kandan	...	Do.	Do.	1,608	172	132	121	91	117	97	32	44	37	17
7	7	Krishnan	...	Kuzhalmannam.	Do.	1,649	188	138	130	103	122	95	33	48	37	16
8	8	Kandan	...	Olavakkot	Do.	1,554	183	134	119	98	131	105	34	46	39	20
9	9	Chemban	...	Mundur	Do.	1,578	180	129	122	91	120	89	25	42	36	16
10	10	Madhavan	...	Do.	Do.	1,598	180	136	120	97	125	105	29	45	36	16
11	11	Kandan	...	Olavakkot	Do.	1,654	180	138	123	97	122	98	32	48	33	18
12	12	Nagan	...	Do.	Do.	1,558	171	136	122	100	129	96	32	42	37	15
13	13	Theyyan	...	Do.	Do.	1,678	185	134	124	96	126	106	25	47	38	16
14	14	Sankaran	...	Do.	Do.	1,614	179	130	111	94	126	97	28	49	42	18
15	15	Raman	...	Do.	Do.	1,581	178	130	119	99	123	105	29	46	39	17
16	16	Kunnan	...	Kuzhalmannam.	Do.	1,638	174	132	113	94	120	98	30	44	34	18
17	17	Raman	...	Pallatheri	Do.	1,684	187	132	128	99	128	99	29	45	41	15
18	18	Nagan	...	Do.	Do.	1,685	180	134	125	87	102	92	31	47	37	16
19	19	Kandan	...	Do.	Do.	1,618	180	127	121	101	128	109	30	51	39	19
20	20	Nagan	...	Do.	Do.	1,614	182	136	128	95	129	120	28	46	44	16
21	21	Kunjan	...	Do.	Do.	1,675	181	133	117	96	125	105	29	47	35	16
22	22	Nagan	...	Do.	Do.	1,554	177	136	120	97	124	103	28	44	37	16
23	23	Palani...	...	Vembalur	Do.	1,606	187	132	124	97	117	107	24	50	37	19
24	24	Kuppandi	...	Pallatheri	Do.	1,519	181	132	123	96	127	98	28	43	38	17
25	25	Kunjan	...	Do.	Do.	1,502	185	131	117	92	127	100	25	46	42	18
26	26	Raman	...	Kuzhalmannam.	Do.	1,619	168	136	116	96	125	97	30	47	38	19

27	39	Palani	30	Do.	...	Do.	...	1,629	180	136	120	99	127	103	36	47	39	18
28	40	Chattan	...	19	Do.	...	Do.	...	1,578	178	137	111	99	126	102	31	46	41	19
29	41	Kandan	...	32	Do.	...	Do.	...	1,584	192	132	130	100	127	92	31	45	39	14
30	42	Kandan	...	30	Do.	...	Do.	...	1,570	174	128	103	96	122	91	30	45	39	18
31	43	Theyyan	...	19	Olavakkot	...	Do.	...	1,595	190	135	124	100	125	97	31	45	37	19
32	44	Kandan	...	65	Alattur	...	Do.	...	1,638	187	137	129	99	133	103	30	46	39	22
33	45	Sanku	48	Kuzhalmannam.	...	Do.	...	1,584	175	129	105	92	128	103	29	48	37	17
34	48	Nagan	...	30	Alattur	...	Do.	...	1,646	180	133	121	97	125	107	33	44	34	16
35	49	Kuppandi	...	59	Do.	...	Do.	...	1,661	186	134	134	97	130	93	30	42	39	17
36	56	Rekkan	...	23	Muringamala	...	Do.	...	1,623	177	137	118	99	131	97	31	48	39	17
37	57	Kandan	...	21	Do.	...	Do.	...	1,619	184	131	114	96	129	102	29	45	39	18
38	58	Palani	...	24	Do.	...	Do.	...	1,629	185	137	124	103	129	104	32	43	38	16
39	59	Vella	...	40	Do.	...	Do.	...	1,634	181	136	127	101	133	106	32	44	40	18
40	60	Kunjan	...	45	Do.	...	Do.	...	1,580	177	136	122	93	123	102	29	46	40	18
41	61	Theyyan	...	35	Chirtlancheri.	...	Do.	...	1,584	182	132	122	95	124	102	30	48	40	17
42	62	Nagan	...	48	Muringamala	...	Do.	...	1,672	186	135	131	104	133	105	34	44	39	19
43	63	Rekkan	...	24	Do.	...	Do.	...	1,553	182	136	117	97	127	99	28	43	33	15
44	67	Nilakandē	...	46	Akalur	...	Walluvanad.	...	1,559	184	135	120	91	124	98	28	40	44	15
45	68	Kandan	...	40	Do.	...	Do.	...	1,617	183	139	114	100	132	101	32	48	42	17
46	69	Chattan	...	33	Peringottu-kurissi.	...	Palghat	...	1,621	181	140	118	102	135	103	29	43	42	17
47	70	Sankaran	...	35	Akalur	...	Walluvanad.	...	1,624	192	128	114	99	122	99	31	40	40	15
48	71	Kunjan	...	45	Do.	...	Do.	...	1,685	190	131	135	97	126	105	27	44	41	16
49	72	Kandan	...	48	Do.	...	Do.	...	1,628	181	125	122	97	122	97	27	46	43	17
50	80	Sankaran	...	60	Kizhur	...	Do.	...	1,617	189	135	113	98	130	92	28	50	41	13
51	81	Koran	40	Do.	...	Do.	...	1,574	192	136	120	94	130	100	26	45	41	15
52	82	Sankaran	...	65	Do.	...	Do.	...	1,514	186	134	118	93	121	86	27	45	41	15
53	83	Raman	...	35	Do.	...	Do.	...	1,609	185	132	121	100	127	99	31	44	38	15
54	84	Theyyan	...	26	Do.	...	Do.	...	1,667	184	137	128	99	129	98	28	46	38	15
55	85	Raman	...	21	Do.	...	Do.	...	1,535	187	132	125	100	121	92	28	44	40	13
56	91	Chattan	...	40	Karakkad	...	Do.	...	1,604	178	134	123	93	126	98	30	44	41	18
57	92	Raman	...	35	Do.	...	Do.	...	1,522	178	132	117	96	124	101	25	39	39	15
58	93	Chattan	...	37	Do.	...	Do.	...	1,602	167	132	112	99	126	90	25	45	38	18
59	97	Theyyan	...	60	Do.	...	Do.	...	1,479	178	125	117	96	125	92	31	45	36	15
60	102	Sankaran	...	28	Karancheri	...	Cochin	...	1,564	178	136	114	95	124	93	24	40	37	14
61	103	Kunhan	...	32	Karakkad	...	Walluvanad.	...	1,471	170	127	111	91	123	90	29	40	37	17
62	104	Sankaran	...	25	Cherpalasserī	...	Do.	...	1,645	188	133	132	99	126	99	29	38	43	14

General Table II-A.—Personalia, Measurements, Indices and Observations on Men—cont.

Serial number.	Number in the observation sheets.	Personalia.				Measurements—mm.							Indices.				
		Name.	Age.	Birth-place.	Taluk.	Orbito-nasal length. (12)	Orbito-nasal arc. (13)	Superior facial length. (14)	Total facial length. (15)	Horizontal circumference of the head. (16)	Sagittal arc of the head. (17)	Transverse arc of the head. (18)	Cephalic index. (19)	Length-height. (20)	Breadth-height. (21)	Transverse front to parietal. (22)	
1	1	Ayyappan	...	22	Kunnankulam.	Cochin State.	94	103	70	115	530	335	328	73.5	67.0	91.2	74.3
2	2	Sankaran	...	30	Do.	Do.	86	99	57	97	510	315	310	76.0	64.6	85.0	71.4
3	3	Raman	...	60	Do.	Do.	87	95	59	107	534	334	308	74.5	60.1	80.7	70.7
4	4	Kandan	...	22	Olavakkot	Palghat	96	108	63	103	530	320	330	75.1	67.0	89.2	71.2
5	5	Rekkan	...	60	Do.	Do.	85	94	58	93	505	308	315	75.1	70.6	94.0	71.4
6	6	Kandan	...	20	Do.	Do.	86	98	62	105	490	308	295	76.7	70.4	91.7	68.9
7	7	Krishnan	...	19	Kuzhalmannam.	Do.	93	102	65	106	540	345	326	73.4	69.2	94.2	74.6
8	8	Kandan	...	49	Olavakkot	Do.	92	101	64	101	525	312	328	73.2	65.0	88.8	73.1
9	9	Chemban	...	28	Mundur	Do.	82	92	57	99	508	305	300	71.7	67.8	94.6	70.5
10	10	Madhavan	...	20	Do.	Do.	89	104	60	104	520	322	320	75.6	66.7	88.2	71.3
11	11	Kandan	...	27	Olavakkot	Do.	89	107	65	112	520	312	320	76.7	68.3	89.1	70.3
12	12	Nagan	...	24	Do.	Do.	90	103	59	98	505	325	307	79.5	71.4	89.7	73.5
13	13	Theyyan	...	47	Do.	Do.	81	90	63	110	525	345	320	72.4	67.0	92.5	71.6
14	14	Sankaran	...	48	Do.	Do.	81	95	62	104	506	315	295	72.6	62.0	85.4	72.3
15	15	Raman	...	65	Do.	Do.	84	95	64	103	510	310	305	72.0	66.9	91.5	76.2
16	16	Kunnan	...	20	Kuzhalmannam.	Do.	89	100	64	102	504	320	306	75.9	64.9	85.6	71.2
17	17	Raman	...	31	Pallatheri	Do.	88	100	64	106	530	325	324	70.6	68.5	97.0	75.0
18	18	Nagan	...	29	Do.	Do.	93	106	69	116	515	345	328	74.4	69.4	93.3	64.9
19	19	Kandan	...	38	Do.	Do.	90	102	66	109	510	325	316	70.6	67.2	95.3	79.5
20	20	Nagan	...	60	Do.	Do.	87	90	61	100	525	330	325	74.7	70.3	94.1	69.9
21	21	Kunjan	...	36	Do.	Do.	89	98	62	103	510	320	315	73.5	64.6	88.0	72.2
22	22	Nagan	...	18	Do.	Do.	93	101	64	107	511	314	328	76.8	67.8	88.2	71.3
23	23	Palani	...	40	Vembalur	Do.	84	90	67	110	528	356	323	70.6	66.3	93.9	73.5
24	24	Kupppandi	...	38	Pallatheri	Do.	84	92	61	102	505	340	308	72.9	68.0	93.2	72.7
25	25	Kunjan	...	58	Do.	Do.	80	90	62	101	515	355	320	70.8	63.2	89.3	70.2
26	26	Raman	...	60	Kuzhalmannam.	Do.	85	101	63	102	494	290	302	81.0	69.1	85.3	70.6

27	39	Palani	...	30	Do.	...	90	101	65	107	515	330	322	75'6	66'7	88'2	72'8
28	40	Chattan	Do.	19	Do.	...	90	100	60	99	512	312	310	77'0	62'4	81'0	72'3
29	41	Kandan	Do.	32	Do.	...	90	102	63	102	534	334	320	68'8	67'7	98'5	75'8
30	42	Kandan	Do.	30	Do.	...	87	100	58	102	495	320	305	73'6	58'9	80'5	75'0
31	43	Theyyan	Olavakkot	19	Do.	...	91	102	62	105	525	345	325	71'1	65'3	91'9	74'1
32	44	Kandan	Alattur	65	Do.	...	85	98	64	108	530	340	330	73'3	69'0	94'2	72'3
33	45	Sanku	Kuzhalnannam.	48	Do.	...	82	60'0	81'4	71'3	...
34	48	Nagan	Alattur	30	Do.	...	93	102	64	108	510	350	315	73'9	67'2	91'0	72'9
35	49	Kuppaundi	Do.	59	Do.	...	88	100	60	96	533	353	325	72'0	72'0	100'0	72'4
36	56	Rekkan	Muringamala	23	Do.	...	89	98	68	107	500	335	314	77'4	66'7	86'1	72'3
37	57	Kandan	Do.	21	Do.	...	86	100	63	107	510	330	317	71'2	62'0	87'0	73'3
38	58	Palani	Do.	24	Do.	...	91	104	66	105	524	355	325	74'1	67'0	90'5	75'2
39	59	Vella	Do.	40	Do.	...	89	101	63	107	520	342	330	75'1	70'2	93'4	74'3
40	60	Kunjan	Do.	45	Do.	...	86	92	62	105	508	332	315	76'8	68'9	89'7	68'4
41	61	Theyyan	Chittilancheri.	35	Do.	98	60	102	515	340	316	72'5	67'0	92'4	72'0
42	62	Nagan	Muringamala	48	Do.	...	93	99	60	113	530	355	320	72'6	70'4	97'0	77'0
43	63	Rekkan	Do.	24	Do.	...	86	96	59	101	515	345	312	74'7	64'3	86'0	71'3
44	67	Nilakandan	Akalur	46	Do.	Walluvanad.	83	90	57	95	...	325	...	73'4	65'2	88'9	67'4
45	68	Kandan	Do.	40	Do.	...	87	94	62	102	520	324	317	76'0	62'3	82'0	71'9
46	69	Chattan	Peringottu-kurssi.	33	Do.	Palghat	93	114	59	101	514	330	320	77'4	65'2	84'3	72'9
47	70	Sankaran	Akalur	35	Do.	Walluvanad.	93	108	57	102	525	335	310	66'7	59'4	89'1	77'3
48	71	Kunjan	Do.	45	Do.	...	90	...	62	111	69'0	71'1	103'1	74'1
49	72	Kandan	Do.	48	Do.	...	89	110	...	107	498	318	315	69'1	67'4	97'6	77'6
50	80	Sankaran	Kizhur	60	Do.	...	89	99	65	105	530	325	310	71'4	60'0	83'7	72'6
51	81	Koran	Do.	40	Do.	...	87	99	63	103	540	320	315	70'8	62'5	88'2	69'1
52	82	Sankaran	Do.	65	Do.	...	89	94	56	100	72'0	63'4	88'1	69'4
53	83	Raman	Do.	35	Do.	...	89	97	66	108	525	340	315	71'4	65'4	91'7	75'8
54	84	Theyyan	Do.	26	Do.	...	90	101	64	105	523	318	320	74'5	69'6	93'4	72'3
55	85	Raman	Do.	21	Do.	...	88	99	64	108	528	345	330	70'6	66'8	94'7	75'8
56	91	Chattan	Karakkad	40	Do.	...	90	98	64	101	503	320	312	75'3	69'1	91'8	69'4
57	92	Raman	Do.	35	Do.	...	80	88	61	101	500	300	330	74'2	65'7	88'6	72'7
58	93	Chattan	Do.	37	Do.	...	87	...	63	104	485	310	305	79'0	67'1	84'9	75'0
59	97	Theyyan	Do.	60	Do.	...	88	94	56	99	514	315	305	70'2	65'7	93'6	76'8
60	102	Sankaran	Karancheri	28	Do.	Cochin	82	95	54	91	506	312	302	76'4	64'0	83'8	69'9
61	103	Kunhan	Karakkad	32	Do.	Walluvanad.	83	90	60	97	478	305	305	74'7	65'3	87'4	71'7
62	104	Sankaran	Cherpalasseri	25	Do.	...	93	102	57	99	520	350	326	70'7	70'2	99'3	74'4

General Table II-A.—Personalia, Measurements, Indices and Observations on Men—cont.

Serial number.	Number in the observation sheets.	Personalia.			Indices—cont.										Skin colour.		Eye colour (Martin).
		Name.	Age.	Birth-place. Taluk.	Nasal elevation. (23)	Nasal length-depth. (24)	Superior facial. (25)	Transverse cephalo-facial. (26)	Total facial. (27)	Zygo-frontal. (28)	Zygo-mandibular. (29)	Forehead. (30)	Upper arm. (31)	(32)	(33)		
1	1	Ayyappan	...	22	Kunnankulam. Cochin State.	81.3	35.9	29.2	53.9	95.6	88.5	77.7	82.3	28	28-29	2	
2	2	Sankaran	...	30	Do.	90.0	41.7	37.5	46.3	92.5	78.9	77.2	78.9	27	28	2	
3	3	Raman	...	60	Do.	84.4	50.0	42.2	43.7	96.4	79.3	73.3	76.3	30	31	2	
4	4	Kandan	...	22	Olavakkot ... Palghat	...	85.1	45.0	38.3	92.8	79.8	76.7	77.5	26	26	1-2	
5	5	Rekkan	...	60	Do.	...	87.5	42.9	37.5	97.0	72.1	73.6	74.4	28	26-27	7	
6	6	Kandan	...	20	Do.	...	84.1	46.0	38.6	88.6	89.7	77.8	82.9	26	29	1	
7	7	Krishnan	...	19	Kuzhalmannam. Do.	...	77.1	43.2	33.3	88.4	86.9	84.4	77.9	26	29	1	
8	8	Kandan	...	49	Olavakkot ... Do.	...	84.8	51.3	43.5	97.8	77.1	74.8	80.2	30	29	1-2	
9	9	Chemban	...	28	Mundur ... Do.	...	85.7	44.4	38.1	93.0	82.5	75.8	74.2	29	29	1	
10	10	Madhavan	...	20	Do.	...	80.0	44.4	35.6	91.9	83.2	77.6	84.0	29	31	1	
11	11	Kandan	...	27	Olavakkot ... Do.	...	68.8	54.6	37.5	88.4	91.8	79.5	80.3	30	31	1	
12	12	Nagan	...	24	Do.	...	88.1	40.5	35.7	94.9	76.0	77.5	74.4	30	30-31	1	
13	13	Theyyan	...	47	Do.	...	80.9	42.1	34.0	94.0	87.3	76.2	84.1	29	31-32	2	
14	14	Sankaran	...	48	Do.	...	85.7	42.9	36.7	96.9	82.5	74.6	77.0	30	30	2	
15	15	Raman	...	65	Do.	...	84.8	43.6	37.0	94.6	83.7	80.5	85.4	30	31-32	2-3	
16	16	Kunjan	...	20	Kuzhalmannam. Do.	...	77.3	52.9	40.9	93.3	90.9	85.0	81.7	30	29-30	2	
17	17	Raman	...	31	Pallatheri ... Do.	...	91.1	36.6	33.3	97.0	82.8	77.3	77.3	30	30	2	
18	18	Nagan	...	29	Do.	...	78.7	43.2	34.0	97.7	76.1	113.7	85.3	30	29-30	2	
19	19	Kandan	...	38	Do.	...	76.5	48.7	37.3	100.8	85.2	78.9	85.2	30	29	2	
20	20	Nagan	...	60	Do.	...	91.3	38.1	34.8	94.9	77.5	73.6	93.0	30	30	2-3	
21	21	Kunjan	...	36	Do.	...	74.5	45.7	34.0	94.0	82.4	76.8	84.0	30	29-30	1	
22	22	Nagan	...	18	Do.	...	84.1	43.2	36.4	91.2	86.3	78.2	83.1	30	30	1-2	
23	23	Palani	...	40	Vembalur ... Do.	...	74.0	51.4	38.0	88.6	94.0	82.9	91.5	30	29-30	2	
24	24	Kuppanadi	...	38	Pallatheri ... Do.	...	88.4	44.7	39.5	96.2	80.3	75.6	77.2	30	32	2	
25	25	Kunjan	...	58	Do.	...	91.3	42.9	39.1	97.0	79.5	72.4	78.7	30	29	2-3	
26	26	Raman	...	60	Kuzhalmannam. Do.	...	80.9	50.0	40.4	91.9	81.6	76.8	77.6	30	29-30	2	

27	39	Palani	30	Do.	...	83.0	46.2	38.3	51.2	93.4	84.3	78.0	81.1	29	29-30	1	
28	40	Chattan	...	19	Do.	...	89.1	46.3	41.3	47.6	92.0	78.6	78.6	81.0	31-32	29-30	2	
29	41	Kandan	...	32	Do.	...	86.7	35.9	31.1	49.6	96.2	80.3	78.7	72.4	31-32	29-30	2	
30	42	Kandan	...	30	Do.	...	86.7	46.2	40.0	47.5	95.3	83.6	78.7	74.6	32	30-31	2	
31	43	Theyyan	...	19	Olavakkot	...	82.2	51.4	42.2	49.6	92.6	84.0	80.0	77.6	30-31	29-30	1-2	
32	44	Kandan	...	65	Alattur	...	84.8	56.4	47.8	48.1	97.1	81.2	74.4	77.4	30	30	2	
33	45	Sanku	48	Kuzhalmannam	...	77.1	46.0	35.4	71.9	80.5	30	30	2	
34	48	Nagan	...	30	Alattur	...	77.3	47.1	36.4	51.2	94.0	86.4	77.6	85.6	30	29-30	2	
35	49	Kuppani	...	59	Do.	...	92.9	43.6	40.5	46.2	97.0	73.9	74.6	71.5	30	29	3	
36	56	Rekkan	...	23	Muringamala	...	81.3	43.6	35.4	51.9	95.6	81.7	77.6	74.1	29	29	2	
37	57	Kandan	...	21	Do.	...	86.7	46.2	40.0	48.8	98.5	83.0	74.4	79.1	29-30	30	2	
38	58	Palani	24	Do.	...	88.4	42.1	37.2	51.2	94.2	81.4	79.8	80.6	25	25	2	
39	59	Vella	40	Do.	...	90.9	45.0	40.9	47.4	97.8	80.5	75.9	79.7	30	29	1-2	
40	60	Kunjan	...	45	Do.	...	87.0	45.5	39.1	50.4	90.4	85.4	75.6	82.9	30	29-30	2	
41	61	Theyyan	...	35	Chittilancheri	...	83.3	42.5	35.4	48.4	93.9	82.3	76.6	82.3	30	30-31	2	
42	62	Nagan	...	48	Muringamala	...	88.6	48.7	43.2	45.1	98.5	85.0	78.2	79.0	30	30	2	
43	63	Rekkan	...	24	Do.	...	76.7	45.5	34.9	46.5	93.4	79.5	76.4	78.0	29	29	2	
44	67	Nilakandan	...	46	Akalur	...	110.0	34.1	37.5	46.0	91.9	76.6	73.4	79.0	32	32	2	
45	68	Kandan	...	40	Do.	...	87.5	40.5	35.4	47.0	95.0	77.3	75.8	76.5	32	34	1-2	
46	69	Chattam	...	33	Peringottu-kurissi	Palghat	...	97.7	40.5	39.5	43.7	96.4	74.8	75.6	76.3	32	33	1
47	70	Sankaran	...	35	Akalur	...	100.0	37.5	37.5	46.7	95.3	83.6	81.2	81.2	30	32	1	
48	71	Kunjan	...	45	Do.	...	93.2	39.0	36.4	49.2	96.2	88.1	77.0	83.3	30	32	1	
49	72	Kandan	...	48	Do.	...	93.5	39.5	37.0	...	97.6	87.7	79.5	79.5	32	33	1	
50	80	Sankaran	...	60	Kizhur	...	82.0	31.7	26.0	50.0	96.3	80.8	75.4	70.8	29-30	30	2	
51	81	Koran	40	Do.	...	91.1	36.6	33.3	48.5	95.6	79.2	72.3	76.9	30-31	32	2	
52	82	Sankaran	...	65	Do.	...	91.1	36.6	33.3	46.3	90.3	82.6	76.9	71.1	33-34	33-34	2	
53	83	Raman	...	35	Do.	...	86.4	39.5	34.1	52.0	96.2	85.0	78.7	78.0	29-30	31-32	2	
54	84	Theyyan	...	26	Do.	...	82.6	39.5	32.6	49.6	94.2	81.4	76.7	76.0	27	29	1	
55	85	Raman	...	21	Do.	...	90.9	32.5	29.6	52.9	91.7	89.3	82.6	76.0	30-31	32-33	1	
56	91	Chattan	...	40	Karakkad	...	93.2	43.9	40.9	50.8	94.0	80.2	73.8	77.8	30	29-30	1	
57	92	Raman	...	35	Do.	...	100.0	38.5	38.5	49.2	93.9	81.5	77.4	81.5	31-32	31-32	1	
58	93	Chattan	...	37	Do.	...	84.4	47.4	40.0	50.0	95.4	82.5	78.6	71.4	29-30	29-30	2	
59	97	Theyyan	...	60	Do.	...	83.7	41.7	34.9	44.8	100.0	79.2	76.8	73.6	30	30-31	3	
60	102	Sankaran	...	28	Karancheri	...	92.5	37.8	35.0	43.6	91.2	73.4	76.6	75.0	29	31	2	
61	103	Kunhan	...	32	Karakkad	...	92.5	46.0	42.5	48.8	96.9	78.9	74.0	73.2	29	29-30	2	
62	104	Sankaran	...	25	Cherpalasseri...	Do.	113.2	32.6	36.8	45.2	94.7	78.6	78.6	78.6	29	29-30	2	

General Table II-B.—Personalia, Measurements, Indices and Observations on Women.

Serial number.	Number in the observation sheets.	Personalia.			Measurements—mm.													
		Name.	Age.	Birth-place.	Taluk.	Stature.	(1)	(2)	(3)	(4)	(5)	(6)	(7)	(8)	(9)	(10)	(11)	
1	17	Vela	...	Olavakkot	...	Palghat	...	1,527	182	132	115	96	116	92	29	42	35	18
2	18	Nani	...	Do.	...	Do.	...	1,537	173	140	116	100	128	100	30	43	35	18
3	19	Ayya	...	Do.	...	Do.	...	1,445	179	129	121	94	120	93	35	44	38	18
4	20	Ayichi	...	Do.	...	Do.	...	1,481	170	139	115	100	123	94	29	42	39	18
5	21	Nili	...	Do.	...	Do.	...	1,494	175	132	112	97	122	94	30	42	35	16
6	22	Ponni	...	Do.	...	Do.	...	1,495	167	127	117	95	120	92	31	43	37	14
7	26	Ponni	...	Pallateri	...	Do.	...	1,425	164	125	108	91	114	88	26	41	32	14
8	27	Ponni	...	Do.	...	Do.	...	1,429	173	130	125	94	119	95	28	42	35	15
9	29	Rekki	...	Do.	...	Do.	...	1,321	161	123	117	88	110	87	25	36	32	15
10	35	Kali	...	Do.	...	Do.	...	1,510	170	131	124	92	115	92	27	39	32	16
11	36	Ayya	...	Do.	...	Do.	...	1,461	172	126	119	96	117	92	27	40	36	16
12	37	Ponni	...	Do.	...	Do.	...	1,468	177	132	111	99	121	96	27	45	36	17
13	46	Ponni	...	Kuzhalmannam.	...	Do.	...	1,400	173	124	108	88	113	91	26	44	35	15
14	47	Ponni	...	Do.	...	Do.	...	1,588	176	131	114	96	120	87
15	50	Nili	...	Alattur	...	Do.	...	1,540	172	130	107	97	119	98	30	42	37	16
16	51	Kuppa	...	Do.	...	Do.	...	1,424	174	122	131	92	112	90	30	40	38	17
17	52	Kali	...	Do.	...	Do.	...	1,514	178	125	117	95	116	93	30	40	36	17
18	53	Ponni	...	Do.	...	Do.	...	1,386	168	125	122	95	115	90	28	40	37	15
19	54	Nili	...	Muringamala.	...	Do.	...	1,425	176	129	116	92	117	90	29	37	33	16
20	55	Ponni	...	Do.	...	Do.	...	1,469	169	129	117	88	112	84	28	40	33	15
21	64	Kali	...	Do.	...	Do.	...	1,460	171	129	120	90	114	91	27	43	35	14
22	65	Nili	...	Do.	...	Do.	...	1,462	166	131	108	97	121	94	30	41	34	16
23	66	Nili	...	Do.	...	Do.	...	1,528	175	130	116	98	118	91	30	45	33	18
24	73	Nili	...	Alattur	...	Walluvanad.	...	1,476	173	124	110	97	120	97	30	43	37	16
25	74	Kali	...	Do.	...	Do.	...	1,388	171	124	110	93	111	90	30	38	36	15

26	75	China	...	28	Do.	...	1,567	181	133	134	96	123	91	28	42	34	17
27	76	Kali	..	25	Do.	...	1,452	174	124	117	97	112	91	30	36	37	14
28	77	Ponni	...	34	Do.	...	1,477	172	128	110	97	121	91	29	38	34	13
29	78	Nili	...	44	Do.	...	1,414	177	137	108	99	120	95	31	43	38	17
30	79	Ponni	...	19	Do.	...	1,367	166	127	110	90	112	86	27	37	33	14
31	86	Ponni	...	35	Kizhur	...	1,444	178	127	116	100	121	99	28	41	35	14
32	87	Kurumba	...	30	Do.	...	1,468	171	127	113	95	117	96	26	41	32	14
33	88	Kali	...	30	Do.	...	1,507	186	126	119	96	121	96	33	37	37	15
34	89	Nili	...	28	Do.	...	1,462	174	129	109	90	113	92	27	37	34	12
35	90	Kali	...	23	Do.	...	1,454	181	134	117	99	127	94	30	37	36	13
36	94	Kurumba	...	30	Karakkad	...	1,405	173	125	108	87	119	95	27	41	35	12
37	95	Kali	...	35	Do.	...	1,402	161	134	101	88	116	89	28	38	33	12
38	96	Armini	...	28	Do.	...	1,462	182	135	120	94	121	94	29	38	33	13
39	98	Kali	...	35	Do.	...	1,472	176	134	118	92	118	91	30	37	38	14
40	99	Nangeli	...	38	Do.	...	1,453	171	135	116	91	119	90	30	35	36	14
41	100	Kali	...	18	Do.	...	1,386	165	125	110	91	112	83	28	37	39	14
42	101	Kurumba	...	25	Do.	...	1,478	178	128	117	95	116	82	29	36	36	16

General Table II-B.—Personalities, Measurements, Indices and Observations on Women—cont.

Serial number.	Number in the observation sheets.	Personalities.			Measurements—mm.								Indices.						
		Name.	Age.	Birth-place.	Taluk.	(12)	(13)	(14)	(15)	(16)	(17)	(18)	(19)	(20)	(21)	(22)			
1	17	Velq	...	51	Olavakkot	...	Palghat	...	84	90	64	105	72.5	63.2	87.1	72.7
2	18	Nani	...	25	Do.	...	Do.	...	90	94	64	107	80.9	67.1	82.9	71.4
3	19	Ayya	...	39	Do.	...	Do.	...	86	98	60	92	72.1	67.6	93.8	72.9
4	20	Ayichi	...	41	Do.	...	Do.	...	90	90	61	102	81.8	67.7	82.7	71.9
5	21	Nili	...	26	Do.	...	Do.	...	89	94	60	104	75.4	64.0	84.9	73.5
6	22	Ponni	...	31	Do.	...	Do.	...	84	90	60	97	76.1	70.1	92.1	74.8
7	26	Ponni	...	30	Pallatheri	...	Do.	...	85	88	57	96	76.2	65.9	84.6	72.8
8	27	Ponni	...	25	Do.	...	Do.	...	85	90	60	94	75.1	72.3	96.2	72.3
9	29	Rekki	...	30	Do.	...	Do.	...	71	80	54	89	76.4	72.7	95.1	71.5
10	35	Kali	...	38	Do.	...	Do.	...	80	90	59	102	77.1	72.9	94.7	70.2
11	36	Ayya	...	39	Do.	...	Do.	...	85	95	62	99	73.3	69.2	94.4	76.2
12	37	Ponni	Do.	...	Do.	...	85	96	63	104	74.6	62.7	84.1	75.0
13	46	Ponni	...	50	Kuzhalmannam.	...	Do.	...	77	84	61	86	71.7	62.4	97.1	71.0
14	47	Ponni	...	47	Do.	...	Do.	74.4	64.8	87.0	73.3
15	50	Nili	...	45	Alattur	...	Do.	...	85	92	65	95	75.6	62.2	82.3	74.6
16	51	Kuppa	...	25	Do.	...	Do.	...	83	93	60	92	70.1	75.3	107.4	75.4
17	52	Kali	...	21	Do.	...	Do.	...	89	100	60	92	70.2	65.7	93.6	76.0
18	53	Ponni	...	21	Do.	...	Do.	...	82	91	59	96	74.4	72.6	97.6	76.0
19	54	Nili	...	30	Muringamala.	...	Do.	...	84	92	56	90	73.3	65.9	89.9	71.3
20	55	Ponni	...	24	Do.	...	Do.	...	82	90	60	95	76.3	69.2	90.7	68.2
21	64	Kali	...	22	Do.	...	Do.	...	83	92	61	95	75.4	70.2	93.0	69.8
22	65	Nili	...	29	Do.	...	Do.	...	86	92	56	92	78.9	65.1	82.4	74.1
23	66	Nili	...	40	Do.	...	Do.	...	88	94	...	105	74.3	66.3	89.2	75.4
24	73	Nili	...	30	Akalur	...	Walluvanad.	...	92	105	56	91	71.7	63.6	88.7	78.2
25	74	Kali	...	30	Do.	...	Do.	...	87	98	53	90	72.5	64.3	88.7	75.0

General Table II-B.—Personalia, Measurements, Indices and Observations on Women—cont.

Serial number.	Number in the observation sheets.	Personalia			Indices.												
		Name.	Age.	Birth-place.	Taluk.	Nasal.	Nasal elevation.	Nasal length-depth.	Superior facial.	Transverse facial.	Total facial.	Zygo-frontal.	Zygo-mandibular.	Forehead.	Upper arm.	Eye colour (Martin).	
						(23)	(24)	(25)	(26)	(27)	(28)	(29)	(30)	(31)	(32)	(33)	
1	17	Vela	Olavakkot ...	Palghat	...	83.3	51.4	42.9	55.2	87.9	90.5	82.8	79.3	30	31	2
2	18	Nani	Do.	Do.	...	81.4	51.4	41.9	50.0	91.4	83.6	78.1	78.1	29	29	1
3	19	Ayya	Do.	Do.	...	86.4	47.4	40.9	50.0	93.0	76.7	78.3	77.5	29	30	1
4	20	Ayichi	Do.	Do.	...	92.9	46.2	42.9	49.6	88.5	82.9	81.3	76.4	30	30	2
5	21	Nili	Do.	Do.	...	83.3	45.7	38.1	49.2	92.4	85.3	79.5	77.1	30	29	1
6	22	Ponni	Do.	Do.	...	86.1	37.8	32.6	50.0	94.5	80.8	79.2	76.7	29	29	1
7	26	Ponni	Pallatheri ...	Do.	...	78.1	43.8	34.2	50.0	91.2	84.2	79.8	77.2	29	29	2
8	27	Ponni	Do.	Do.	...	83.3	42.9	35.7	50.4	91.5	79.0	79.0	79.8	30	30	2
9	29	Rekki	Do.	Do.	...	88.9	46.9	41.7	49.1	89.4	80.9	80.0	79.1	30	29-30	2-3
10	35	Kali	Do.	Do.	...	82.1	50.0	41.0	51.3	87.8	88.7	80.0	80.0	30	29	2-3
11	36	Ayya	Do.	Do.	...	90.0	44.4	40.0	53.0	92.9	84.6	82.1	78.6	30	29	1
12	37	Ponni	Do.	Do.	...	80.0	47.2	37.8	52.1	91.7	86.0	81.8	79.3	30	30	2
13	46	Ponni	Kuzhalmannam.	Do.	...	79.6	42.9	34.1	54.0	91.1	76.1	77.9	80.5	30	30	2
14	47	Ponni	Do.	Do.	91.6	...	80.0	72.5
15	50	Nili	Alattur ...	Do.	...	88.1	43.2	38.1	54.6	91.5	79.8	81.5	82.4	29-30	30	2
16	51	Kuppa	Do.	Do.	...	95.0	44.7	42.5	53.6	91.8	82.1	82.1	80.4	30	30	1
17	52	Kali	Do.	Do.	...	90.0	47.2	42.5	51.7	92.8	79.3	81.9	80.2	32	30-31	1
18	53	Ponni	Do.	Do.	...	92.5	40.5	37.5	51.3	92.0	83.5	82.6	78.3	30	30	1
19	54	Nili	Muringamala.	Do.	...	89.2	48.5	43.2	47.9	90.7	76.9	78.6	76.9	29	29	2
20	55	Ponni	Do.	Do.	...	82.5	45.5	37.5	53.6	86.8	84.8	78.6	75.0	30	30	1
21	64	Kali	Do.	Do.	...	81.4	40.0	32.6	53.5	88.4	83.3	79.0	79.8	28	29	1-2
22	65	Nili	Do.	Do.	...	82.9	47.1	39.0	46.3	92.4	76.0	80.2	77.7	29	29	2
23	66	Nili	Do.	Do.	...	73.3	54.6	40.0	...	90.8	89.0	83.1	77.1	30	29	1-2
24	73	Nili	Akalur ...	Walluvanad.	...	86.1	43.2	37.2	46.7	96.8	75.8	80.8	80.8	31	33	1
25	74	Kali	Do.	Do.	...	94.7	41.7	39.5	47.8	89.5	81.1	83.8	81.1	31	31-32	1

26	75	China	...	28	Do.	...	81.0	50.0	40.5	48.0	92.5	80.5	78.1	74.0	30	30	1
27	76	Kali	...	25	Do.	...	102.8	37.8	38.9	46.4	90.3	80.4	86.6	81.3	30	30	1
28	77	Ponni	...	34	Do.	...	89.5	38.2	34.2	44.6	94.5	73.6	80.2	75.2	32	31-32	1
29	78	Nili	...	44	Do.	...	88.4	44.7	39.5	53.3	87.6	80.8	82.5	79.2	30	31-32	1
30	79	Ponni	...	19	Do.	...	89.2	42.4	37.8	50.0	88.2	81.3	80.4	76.8	31	32-33	1-2
31	86	Ponni	...	35	Kizhur	...	85.4	40.0	34.2	52.9	95.3	84.3	82.6	81.8	29	30	1
32	87	Kurumba	...	30	Do.	...	78.1	43.8	34.2	49.6	92.1	74.4	81.2	82.1	29	29	1
33	88	Kali	...	30	Do.	...	100.0	40.5	40.5	49.6	96.0	82.6	79.3	79.3	31-32	31-32	1
34	89	Nili	...	28	Do.	...	91.9	38.2	35.1	51.3	87.6	83.2	79.7	81.4	29	29	1
35	90	Kali	...	23	Do.	...	97.3	33.3	32.4	43.3	94.8	71.7	78.0	74.0	29-30	29-30	1
36	94	Kurumba	...	30	Karakkad	...	85.4	34.3	29.3	47.9	95.2	74.8	73.1	79.8	29-30	30-31	2
37	95	Kali	...	35	Do.	...	86.8	36.4	31.6	44.8	86.6	70.7	75.9	76.7	26-27	28	2
38	96	Amraini	...	28	Do.	...	86.8	39.4	34.2	57.0	89.6	80.2	77.7	77.7	29	29-30	2
39	98	Kali	...	35	Do.	...	102.7	36.8	37.8	48.3	88.1	78.0	78.0	77.1	28-29	29	2
40	99	Nangeli	...	38	Do.	...	102.9	38.9	40.0	42.0	88.2	75.6	76.5	75.6	30	29-30	2
41	100	Kali	...	18	Do.	...	105.4	35.9	37.8	47.3	89.6	82.1	81.3	74.1	29-30	30	2
42	101	Kurumba	...	25	Do.	...	100.0	44.4	44.4	45.7	90.6	78.5	81.9	70.7	29	29	2

APPENDIX II.

Glossary of Malayalam terms used in the text.

- Achchāra-kalyānam* = betrothal ceremony.
Aḍuttōn = barber priest.
Akka = elder sister.
Añjali = palms joined together in worship.
Annam = food.
Annan = elder brother.
Arāppu = a kind of cry.
Aśvati = name of an asterism.
Aṭiyam = slave; self-depreciatory term used by the inferior in speaking with a superior.
Attāram = evening meal.
Bali = offering to spirits; a triangular framework with wicks to exorcise spirits.
Bandhukkaḷ = those related by marriage.
Bharaṇi = name of an asterism.
Chakkukmukki = quartz and steel strike-a-light.
Chandālas = a generic name for the lowest of Hindu castes.
Changanāḍu = the shamanistic name for the cock.
Cheri = group of huts of the lowest caste in the Tamil districts.
Cheruman = one of the lower castes of Malabar.
Chīru = evil-eye of women who have recently lost their children.
Chōru = boiled rice.
Dānam = gift.
Deśam = village.
Dhanurvedam = Hindu science of archery.
Diwān = chief executive officer of native states in India.
Gulikan = Son of Saturn.
Iraṇan = one of the lower castes of Malabar.
Ilam = clan; Namputiri house.
Inangu = group of people related by marriage.
Iyyōla = lead-leaf; the name of an ear-ornament made of lead.
Jātinirṇayam = name of a Malayalam work on caste.
Jivan = life.
Kaḍukkan = ear-ornament for men.
Kaikkāran = attendant.
Kāladānam = death-gift.
Kālam = designs of flour made for ritual purposes.
Kalari = fencing ground; place where magical ceremonies are conducted.
Kallu = toddy.
Kallum tōlum vekkal = placing the stone and twig of leaves after burial.
Kanni = virgin; name of a goddess.

- Kaññi* = gruel.
Kāraṇavan = the oldest male member of a joint family.
Karinkannu = evil-eye.
Kāṭṭāla = man of the jungle.
Kāvu = grove or temple.
Keralōḷpatti = the name of a Malayalam work on the origin of Malabar.
Kiṛjāti = lower castes.
Kuntāni = wooden mortar.
Kuṭivekkuka = housing spirits.
Kuṭumi = tuft of hair on the crown of the head.
Maladaivam = hill good.
Mālar = parched rice.
Malayan = name of a hill-tribe of Malabar.
Maṇiyakkāran = manager of a temple ; priest's assistant.
Mannanār = title of a Tiyan chief.
Mannu = the sacred spot in a Nayadi settlement where pieces of stone representing ancestors, etc., are placed.
Mantra = magical formula.
Marattōda = ear-ornament of wood.
Marattōn = 'he of the trees', term by which Pulayans address Ulladans.
Marumakkattāyam = matrilineal inheritance.
Māṭṭal = magical interdiction.
Meljāti = upper caste.
Miṇṇam = open space round a house.
Molayan = title by which Cherumans are addressed ; a young Nayadi.
Moplah = Mohammedans of Malabar.
Mundu = loin-cloth.
Mūrti = spirit.
Muttappan = grandfather ; the title of Iṛavans ; the name of a god.
Nāḍu = country.
Nampūtiri = local name for Brahmins of Malabar.
Nāṭṭu nīchanmar = low castes of the country.
Nāvēru = evil effect of the spoken word.
Nāya = dog.
Nāyādi = hunter.
Niṛalu keṭṭal = tying the shadow ; name of a rite in connexion with the raising of the manes.
Nir atṭipper = right obtained by water-pouring ceremony.
Ōnam = name of the most important national festival of the people of Malabar.
Ōṭṭukattī = ear-ornament of bell-metal.
Pāla = leaf-sheath of the areca palm.
Pandal = a shed.
Paniyan = name of a hill-tribe.
Pappadam = fried gram cakes.
Para = a measure.
Pennu = woman or wife.

- Pichcha* = charity.
Pulakkār = those who are under death pollution.
Pula-piti-kālam = capture-by-Pulayan-season, when upper caste women run the risk of being captured by low caste men.
Pulayan = name of one of the lower castes.
Puli-daivam = tiger god.
Ravukka = bodice.
Sāmūtiri = Zamorin Rajah of Calicut.
Śeshakkār = agnates.
Śesham = remnant of the shroud.
Śvapacha = dog-eater.
Talakkal = tying or attaching.
Tāli = metal plates with cast or embossed figures used as an ornament.
Tali = sprinkling to remove pollution.
Tampi = younger brother.
Tampurān = lord.
Tandān = one of the lower castes of Malabar.
Tankai = younger sister.
Tarvād = clan.
Taviḍu = rice bran.
Tendal = beating (in hunts).
Tinṭal pūra = "pollution rock," the name of a landmark near a village in South Malabar beyond which Nayadis should not go lest the village should be polluted by their approach.
Tiraṅtu Kalyāṇam = menstrual ceremony.
Tiyan = one of the lower castes of Malabar.
Tōda = an ear-ornament.
Tulasi = *Ocimum sanctum*.
Uchchimahākāli = the name of the demoness of cholera.
Ullādan = one of the lower castes in Southern Cochin and the adjoining regions of Travancore who, though distinct from the Nayadis, are often mistaken for them.
Ummaram = a raised platform round the house.
Unṇi = a young person of rank; a child.
Ura! = a tall mortar.
Uri = a rope support for keeping vessels suspended.
Ūrpalli = place where game is broken up.
Uyir = life or energy.
Vāl = sword; the euphemistic name of shaman's sickle.
Vaṇṇān = washerman; also called *Mannān*.
Varṇa = class; often wrongly translated as caste.
Vēdan = hunter.
Vishu = name of a festival in April.
Vishṇu = a member of the Hindu Trinity.

INDEX

A	PAGE	C—cont.	PAGE	D—cont.	PAGE
Admission to schools, diffi-		Change, prejudice against ...	86-87	Distrain, with leaves ...	64
culties in getting ...	94	Charity ...	4	Divorce ...	58
Age of puberty ...	59	manner of giving ...	42	Dog-eaters, alternative caste-	
Aiyandar ...	46, 73	Chatan, godling ...	73	name ...	15
Almighty, Sun identified with.	80	Rites in honour of.	75	Dowry, of leaf-sheaths ...	21
Amulets ...	90	Cherumans ...	16, 29	Dreams ...	80-81
Anæsthesia, in shamanism ...	77-8	opposition to		Dress ...	85 ff
Arabs ...	3	Nayadi reclamation...	98	Drinks... ..	53
Armlets, Ancestral ...	68, 73	Chief, Installation of ...	40-41	Durkheim, on death tabus ...	63
Arms Act ...	46	Chin ...	118		
Assaults on Nayadis ...	99	Christians, Syrian ...	4, 17, 18	E	
Atiyar (slave) ...	17	Circumambulation ...	77	Ear-boring ...	62
Auricular height, Method of		Civic rights, Establishment of	98-99	Ear-lobes, mode of enlarging.	88
measuring ...	106	Clan ...	29	Elders, worshipped ...	78
Ayyappan ...	46, 47, 49, 50	of chief ...	31	Etiquette, in betel-chewing ...	54
		exogamy ...	30	in eating ...	55
B		Codrington ...	3	among caste men...	35
Bali, sacrificial food ...	64-5, 66, 67	Colony schemes ...	91-94	in meeting supe-	
Bananas, Cooking of ...	52	Conch, Rings of ...	89	riors ...	17
Bandhu ...	32, 33	Connor, on the uniqueness of		at toddy shops ...	53
Barbers, Inangans as ...	33	the Nayadis ...	11	Euphorbia, in magical rite for	
Barbosa, on kidnapping by		Conolly, efforts for Nayadis ...	90	improving lactation ...	60
low castes ...	20	Consumption of food ...	54	Evil eye ...	42, 85
Barks, for ropes ...	26	Conversation, caste etiquette		Evil tongue ...	85
as soap ...	27	in ...	17	Exorcism, process of ...	82
Barter ...	51	Conversion ...	90-91		
Basel Mission, Work of ...	90	Couvade ...	21	F	
Beaters, Nayadis as ...	46	Thurston on ...	60	Face ...	107-108,
Beggars, Tribes of ...	29	Cremation ...	66-67	112-113, 117	
Begging, 3, Institutionalised	41-42	Cross-Cousin ...	37, 40, 56	Family, disharmony due to	
on the road-side ...	43	Crows, Feeding of ...	65	mother-in-law ...	37-8
Beliefs ...	80 ff	Curses ...	44, 80	distribution of food	
Betel-chewing ...	54	D		within ...	55
Betrothal ...	56	Danam ...	42	joint ...	32
Bones, taken to birth-place ...	67	Dance, at death-rites ...	69ff	Famine, season of ...	54
Boundary, between the living		Day, Francis, on Conolly's		Fashion, changes in ...	86
and the dead ...	64	work ...	12	Father, changes in the relation-	
Bride-wealth ...	56, 57	Death, Contribution by re-		ship term for ...	35-36
return of ...	58	lations at ...	63	Fire-making, methods of ...	27
Brother-in-law, Attitude to ...	37	Rites in connexion		trials of ...	28
Buchanan, on reclamation ...	10-11	with ...	62 ff	Fire-walking ...	75
Buddhist sculptures, enlarged		Death-gift ...	43	Firth, R., on the study of	
ear-lobes in ...	89	Divination at the		native diet ...	51
Burial ...	63-64	time of ...	44-5	(footnote)	
C		Copper rings ...	90	Fish-tail palm, food from ...	52
Caps ...	85	Degradation, Causes of ...	21	Food, sacrificial ...	64 ff.
Caste ...	1, 5, 6	Deity, magical ...	8	Foote, Bruce ...	3
Ambivalence in ...	20	as the magician's ser-		Forehead ...	117
Correlation of nasal		vant ...	83		
index with ...	111	Demoness of Cholera ...	25	G	
Exterior group of ...	6	Desam ...	29	Game, distribution of ...	47
Keralolpatti on ...	7	Dharmam ...	42	hunter's special names	
Origin of professional		Diet ...	51 ff	of ...	47
groups within ...	33	Distance Pollution ...	18-19	Ganapati, invoked in magic.	81-82
Segregation on account		Blood letting			
of ...	23	to remove ...	18		
Census ...	6-7				

PLATE I

	Name.	Sex.	Age.	Stature.	C.I.	N.I.	Skin Colour	Eye Colour
Figs. 1-4	Chattan	Male	40	1604 mm	75.28	93.18	30	2
Figs. 5-8	Sankaran	Do.	25	1645 mm	70.74	113.16	30	1

Note the tendency to baldness, the presence of a moderate quantity of body hair and the broad and high forehead of the first individual and the sparse body hair, extreme prognathism, very broad how nose, and broad inter-orbital space of the second. The two are closely related and yet show these marked difference in facial characters though they agree in most others.

(42 / 50

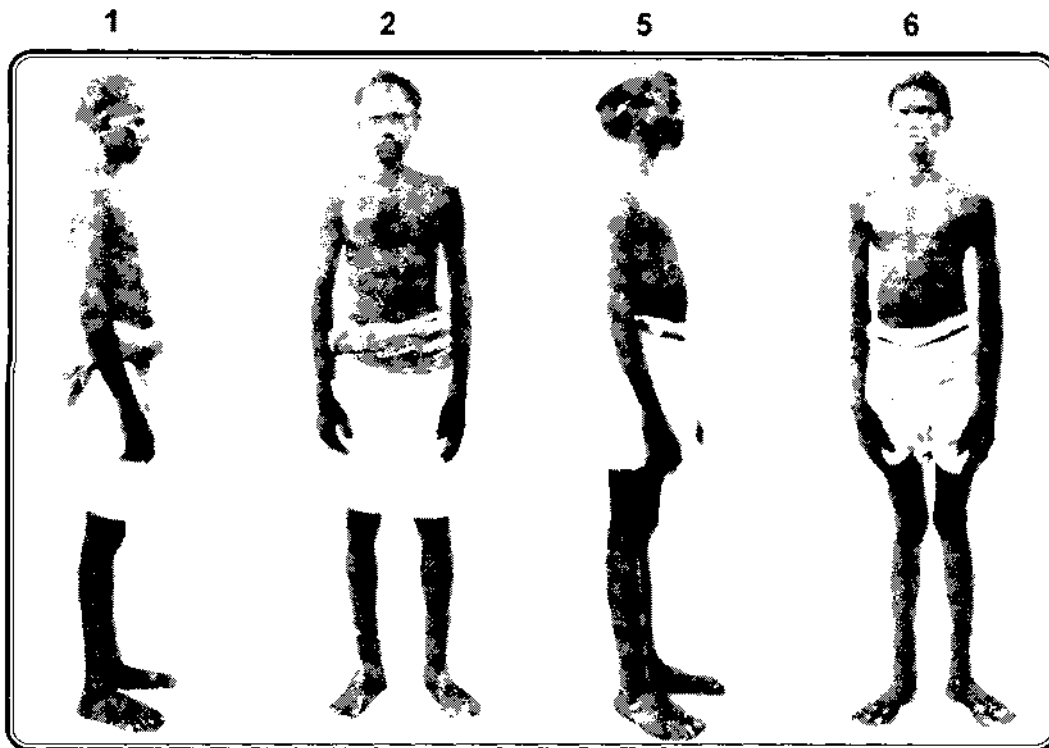
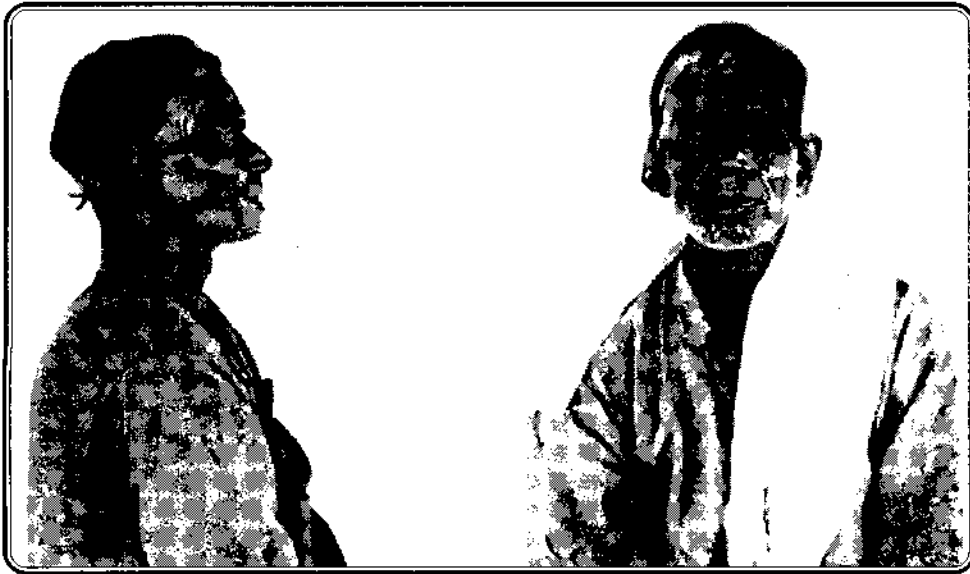

PLATE II

Name.	Sex.	Age.	Stature.	C.I.	N.I.	Skin Colour	Eye Colour	
Figs. 1 & 2 Raman	Male	65	1581 mm	73.03	84.78	30-31	2
Figs. 3 & 4 Kandan	Male	27	1654 mm	76.67	68.75	Do.	1
Figs. 5 & 6 Vela	Female	51	1527 mm	72.53	83.33	Do.	2

The Three persons are father, son and mother.

1



2

3



4

5



6

PLATE III

- Fig. 1. Ponni of Kizhoor village. Note her ornaments of beads and chank shell rings, unkempt hair, enlarged ear-lobes and broad face.
- Fig. 2. Kali of Kizhoor. Simpler ornaments of beads of one uniform kind. Note here the short face and the conical breasts which a large number of Nayadi women have.
- Fig. 3. Mother and children at the State Colony for Nayadis. They came from Anjur (see the map). The old woman's hair was clipped short during a recent illness. Note how her loin cloth is held fast by being tucked below the navel. One of the boys has his head clean shaven which is the custom of the Cherumans, agricultural serfs.
- Fig. 4. A typical Nayadi family. The boy on the left with the sling on his shoulder had just come from the field which he was watching. Next to him is his sister's husband, who works at times on the farm of some Mohammedans. The young woman with the child on her left hip is the wife and the other woman is her mother, who has come to stay for a short period to help her daughter. Two of the three children have begun to wear *mundu* (loin cloth)
- Fig. 5. The hut of a prosperous family at the Carleston Home at Kuzhalmannam in the Palghat taluk. All round the hut are banana trees. Water pots, palm-leaf umbrellas, and baskets are seen in front of the hut. Near the umbrella, the small doorway of the cellar where poultry are sheltered at night can be seen.



1



3



2



4



5

PLATE IV

- Fig. 1. Inmates of the hut in plate iii, fig. 5. The youth at the centre, with a belt round his waist over his *mundu*, is one of the half dozen literate Nayadis. He was nominated as a member of the Palghat taluk board. Second from the left is his wife with a blouse on, and next to her is her mother-in-law with her body bare.
- Fig. 2. Nayadi school at Olavakkot. The headmaster is a Namputiri Brahmin and the other teacher a Christian woman. A few children of other castes that will usually be considered polluted by Nayadis attend the school, but they have to bathe on their return home.
- Fig. 3. Basketry class for adults of the Olavakkot settlement. The teacher is a member of the Kanakkan caste, an untouchable caste.



1

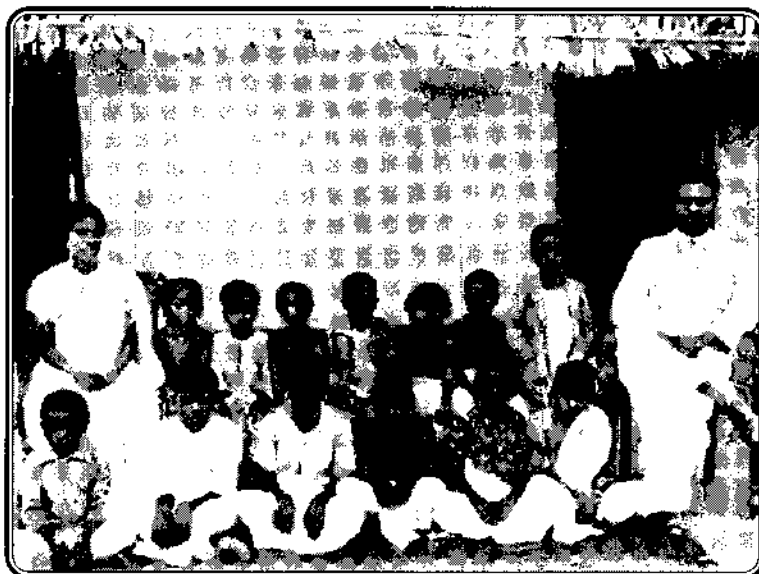

2



3

PLATE V

- Fig. 1. Fashionable young man, with a turban on his head, an umbrella and a walking stick, starting on his begging rounds.
- Fig. 2. *Left* - Old fashioned dress. In the place of the turban there is a leaf cap. The rope bag slung on the man's shoulder is to keep odds and ends that are got on the way.
Right-Boy with his hair cropped, spinning cotton which he is taught at the Industrial School at the Kunnamkulam colony in Cochin State.
- Fig. 3. Raman, the *Mutta* Nayadi (elder) at Kunnamkulam. He is the Zamorin of his people.
- Fig. 4. Chattan, mourning for his mother. He has to grow his beard and hair on the head for a period of twelve months.
- Fig. 5. *Left* - Kandan the richest of all Nayadis. He grew rich by money lending.
Right - The first Nayadi to enter public service as an office servant in the court of the District Munsif at Palghat.

1



2



3



4



5

PLATE VI

- Fig. 1. Stone representation of Uchchimahakali, the goddess of cholera, on a small mound of earth installed after an epidemic of cholera at the village of Pallatheri.
- Fig. 2. The *mannu*, sacred spot, near the Nayadi huts in Kuzhalmannam. Here there are both crude stones and also wooden figures to represent the ancestors.
- Fig. 3. Wooden figures of ancestors, and a mounted god, probably, Aiyandar. Some of them were badly eaten by white ants. (Nayadi settlement near Pattambi in Malabar).
- Fig. 4 & 5. The crude shed in which wooden figures were kept. The stone representations of gods, etc., are on the right.

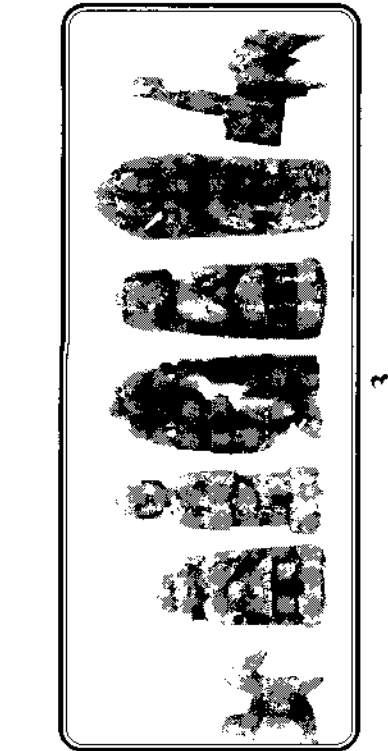

3



5

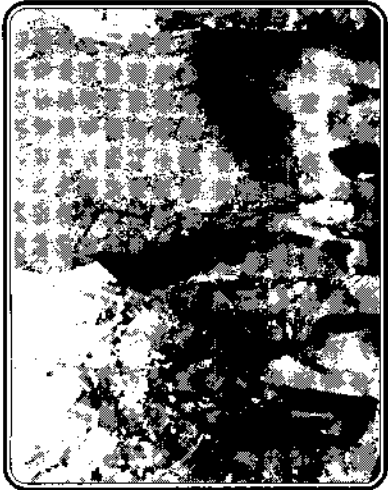

2



4

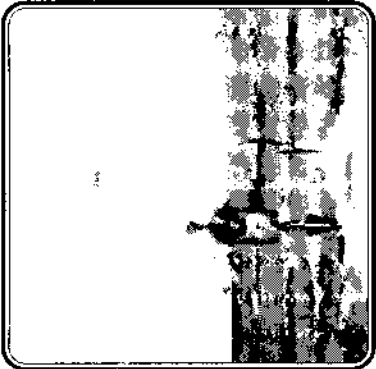

1

PLATE VII

Fig. 1. Circule of stones under a tree to represent ancestors and gods (from Thurston).



1

PLATE VIII

- Fig. 1. Nayadis using a fire-drill (from Thurston).
- Fig. 2. The inside of the Nayadi shrine built for them by the Madras Government at the Olavakkot colony. The stone representations of the gods and ancestors, the walking stick of one of the latter, the bottle of arrack (spirituous liquor) offered at a recent sacrificial offering and the feathers of a cock that was killed are to be seen.
- Fig. 3. The usual open air type of *mannu* (sacred spot) at Kunnamkulam. The linear patches of white flour are remnants of the designs drawn at previous night at the time of the rites in honour of the gods. Leaning against the tree is a long-handled sickle (*Val*) used by the shaman (*Komaram*) of the Gods when he dances.

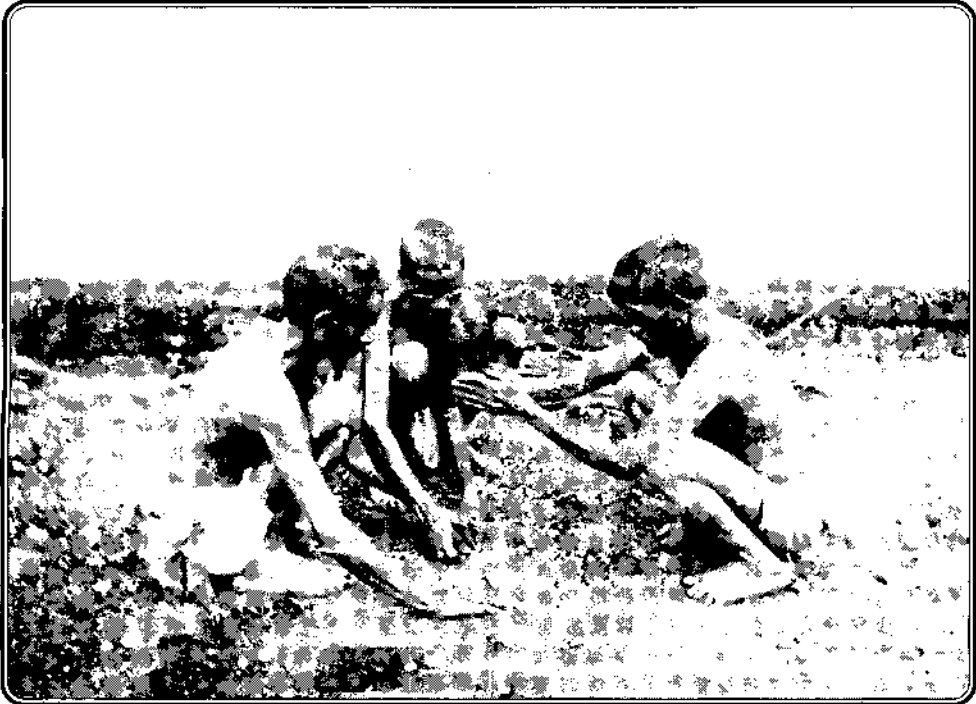

1

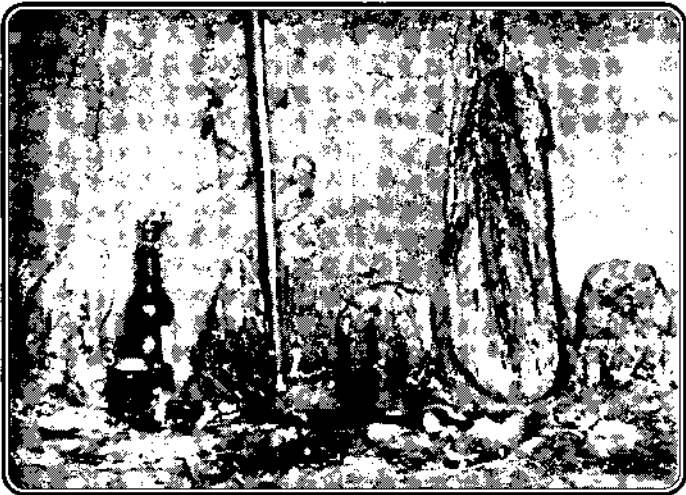

2



3

PLATE IX

- Fig. 1. Brass armband (natural size) with the figures of ancestors on it.
- Fig. 2 & 3. Images of Nayadi gods in the Berlin Museum for Volkerkunde, No.w.k. 84. (after Jagor).
- Fig. 4. *Tali* (a neck ornament worn by women) with the figure of an ancestress in low relief on it.
- Fig. 5. Scroll of pandanus leaf for wearing in the enlarged ear-lobe by women.
- Fig. 6. Copy of the above in lead.
- Fig. 7. Wooden *koradu* for insertion in the ear.
- Fig. 8. Wooden *toda* (ear ornament).

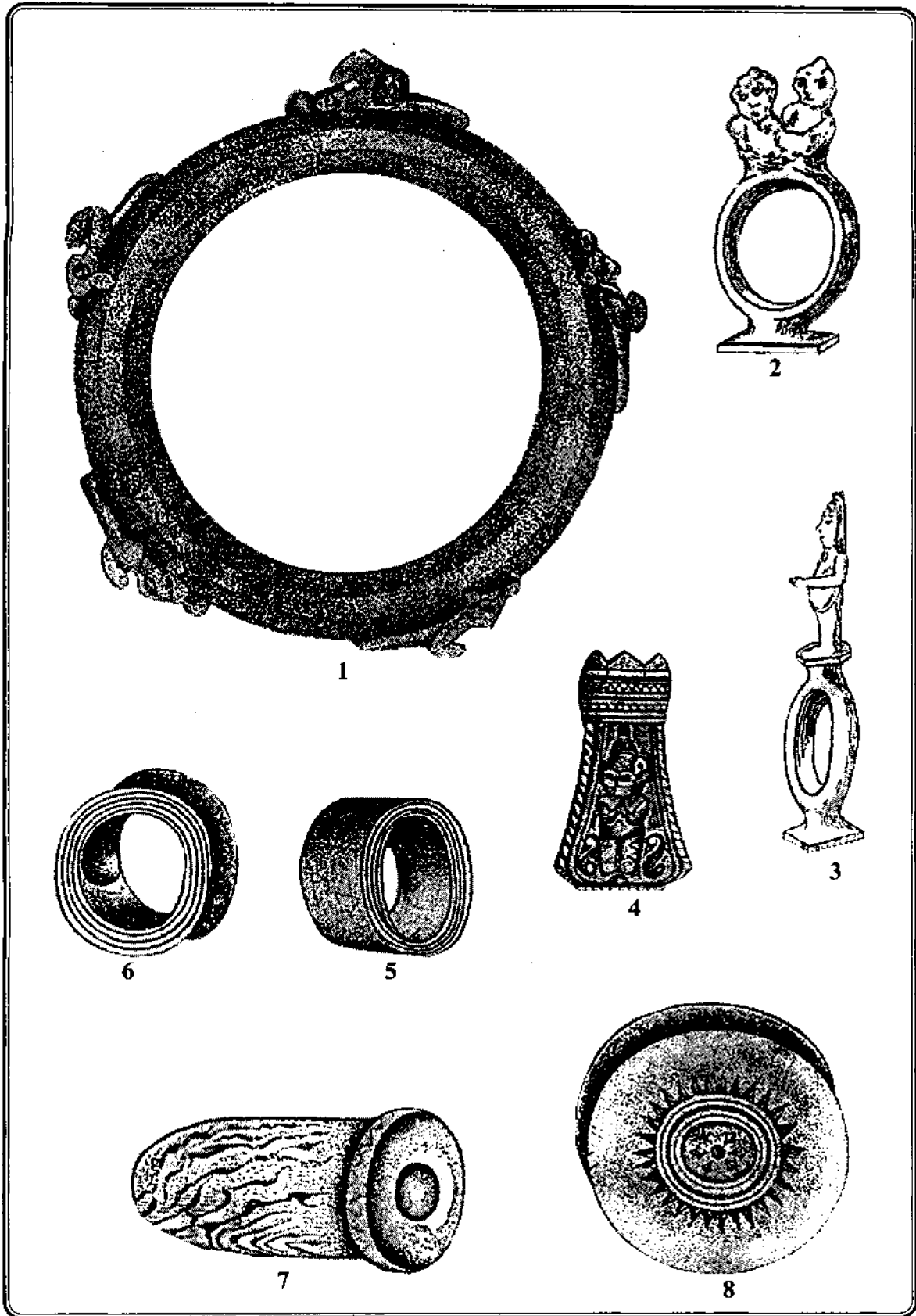

PLATE X

- Fig. 1. Plan of a Nayadi hut.
(For details see pages 24-5)
- Fig. 2. *Uri*, a support used for keeping vessels of food free from ant and vermin, usually suspended from rafters. The Nayadis specialise in the manufacture of these *uris*.
- Fig. 3. Ropes used for restraining dogs during hunting.
- Fig. 4. Sling made of strings of coconut fibre.
- Fig. 5. Lunette shaped ornament of shell worn by Nayadi women (after Hutton). The specimen figured is very rare and is in the State Museum at Trichur.
- Fig. 6. An amulet case worn as a neck ornament by women.
- Fig. 7. Ear-ring for men.
- Fig. 8. Amulet case (*elassu*) worn either on the waist string or round the neck.

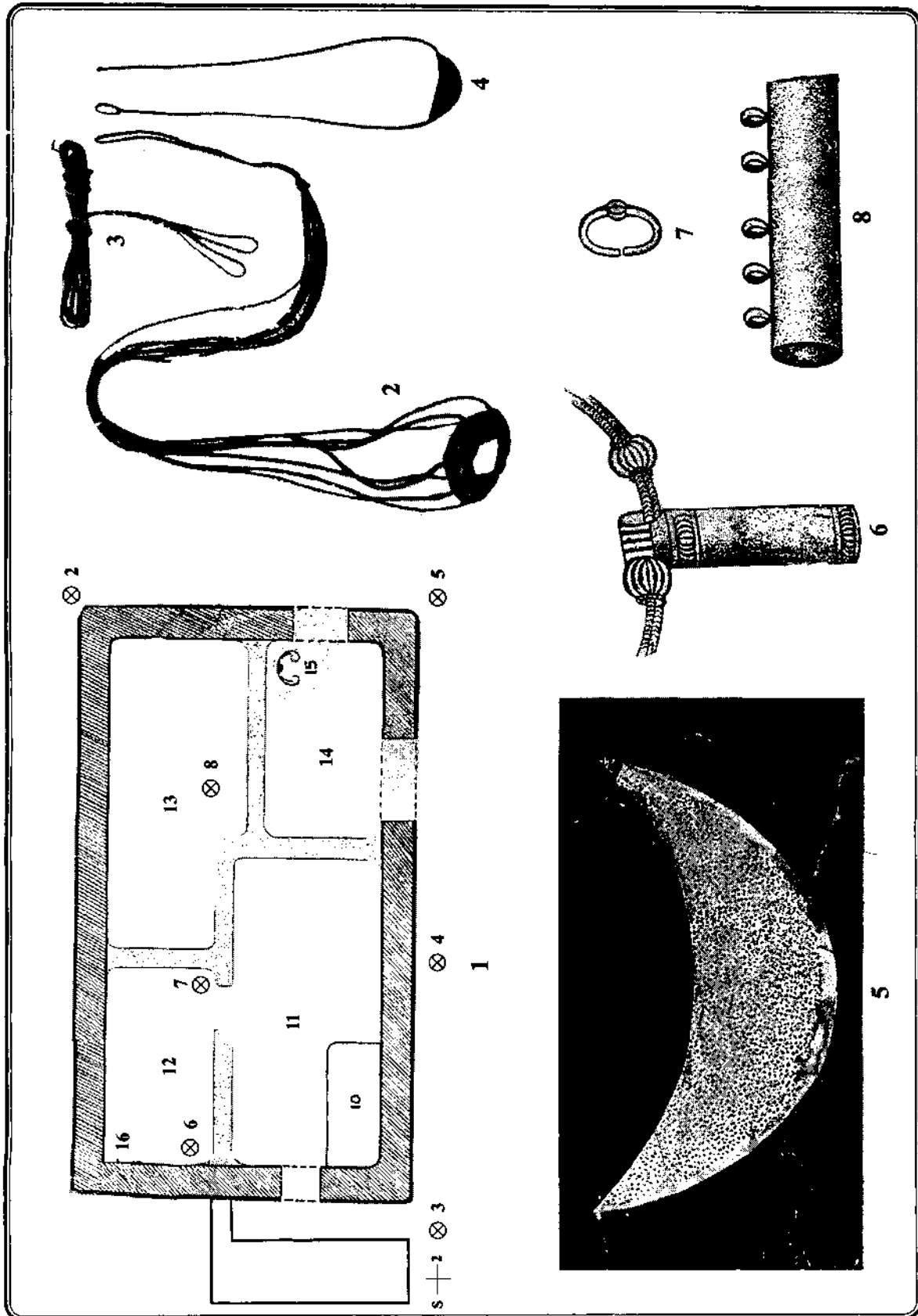

PLATE XI

- Fig. 1. Bow-trap for catching rats.
Fig. 2. Fire-drill.

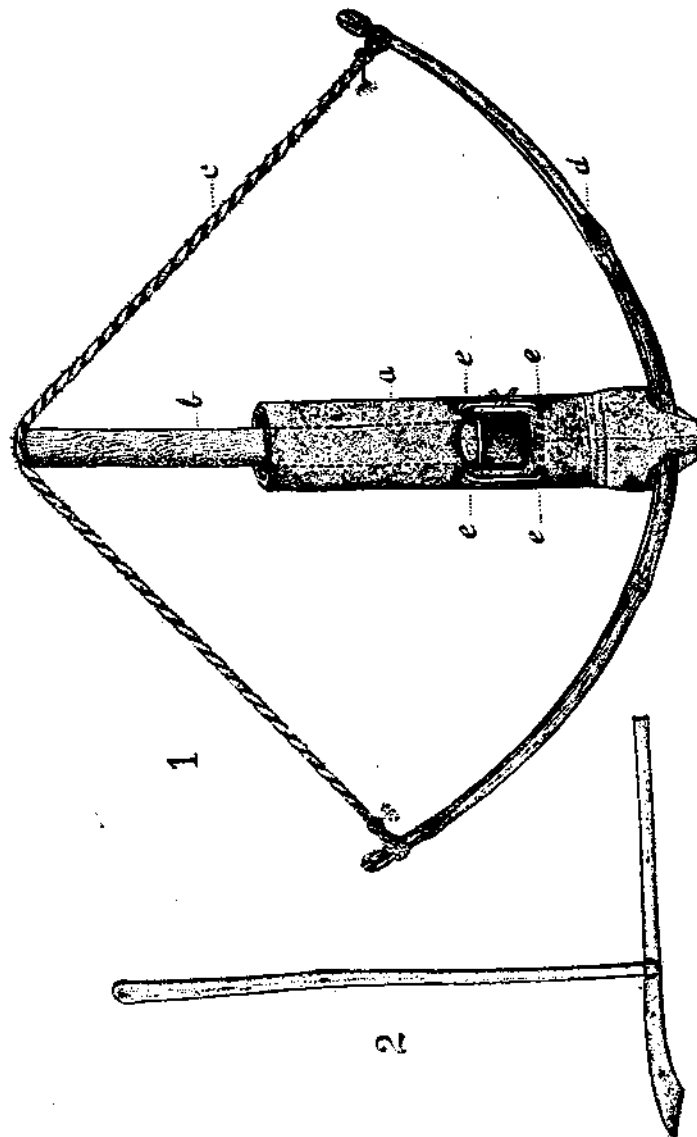
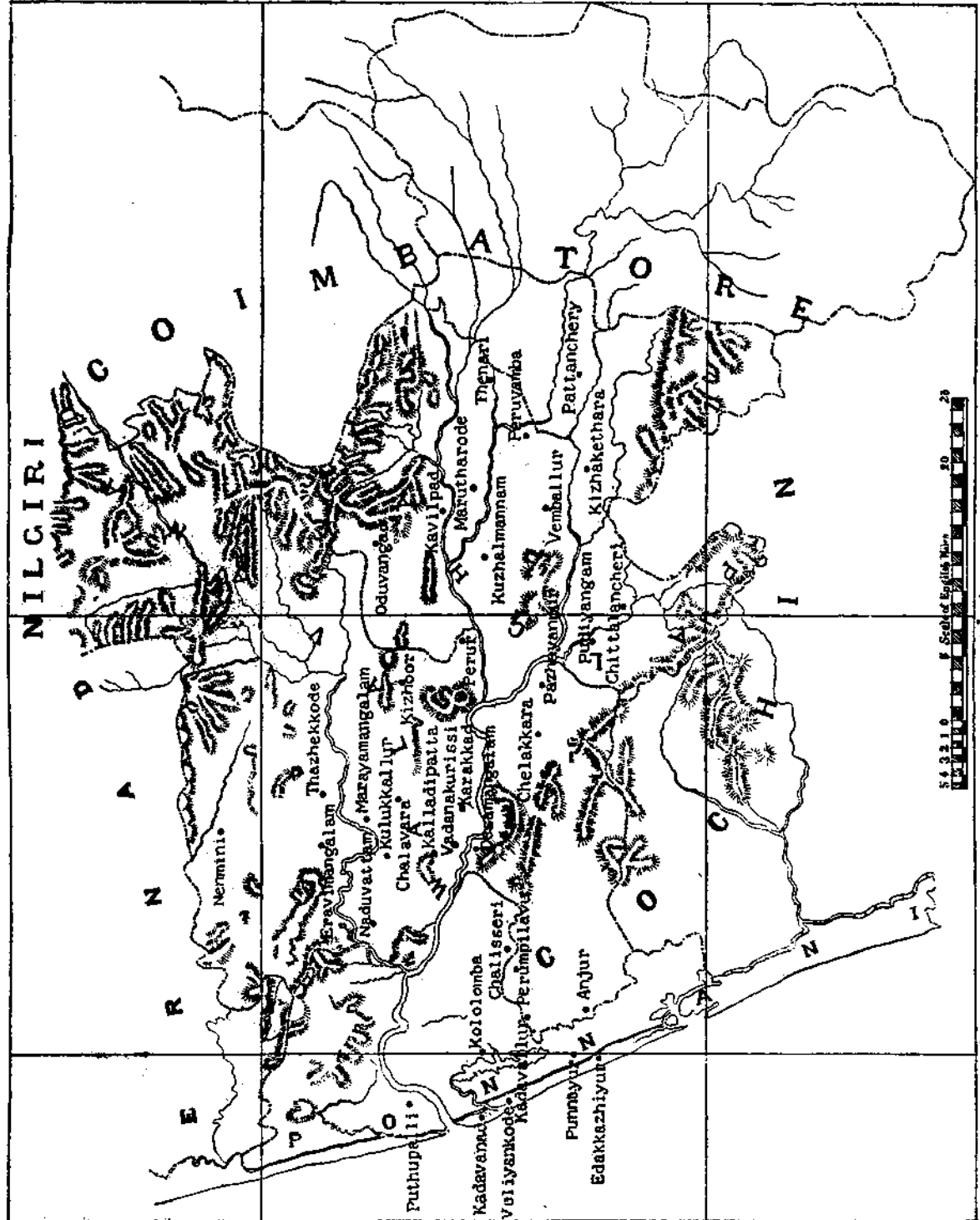

PLATE XII

Map of the southern taluks of the Malabar district in the Madras Presidency, and the northern taluks of Cochin State, showing the villages in which Nayadis are chiefly found.



5 4 3 2 1 0
 1 2 3 4 5 6 7 8 9 10 20 30
 Scale of English Miles

76 30

76

10 30

11

